

T13

12/24V

ADVANCED BATTERY TESTER





**Digital-Batterie-und Ladesystemtester
mit integriertem Drucker**

P3- P12



**Battery Electrical System Analyser
with integrated printer**

P13- P22



Testeur de batterie avec imprimante intégrée

P23- P32



Analizzatore impianto elettrico batteria

P33- P42



Analizador de batería y de sistema eléctrico

P43- P54



Bedienungsanleitung

- Der T13 Batterie Tester arbeitet auf 12V- und 24V-Systemen und kann vier Tests durchführen:
- Batterietest: Analysiert den Batteriezustand mit einem mikroprozessorgesteuerten Prüfverfahren (12V-Bat)
- Karosseriemasse: Analysiert den Zustand des elektrischen Rücklaufkreises (nur 12V System).
- Startertest: Überprüft die Anlassleistung der Batterie, um vorherzusagen, wann die Batterie ein Fahrzeug nicht anlassen kann (12V/24V System).
- Generatortest: Dieser Test überprüft den Zustand der Lichtmaschine, indem er sie unter verschiedenen Belastungen testet und ein Diodenwelligkeitstest (12V / 24V System) durchgeführt wird.

Betriebsablauf:

- Schließen Sie die Klemmen des T13 an die Batterieklemmen an, um es einzuschalten. Die Batteriespannung wird auf dem Bildschirm angezeigt.
- Drücken Sie eine beliebige Taste, um zum Startbildschirm zu kommen. Auf dem Startbildschirm stehen verschiedene Modus zur Verfügung:

a. Detaileintrag	b. Test	c. Speicher	d. Einstellungen
------------------	---------	-------------	------------------
- Um Workshop-Informationen einzugeben, wählen Sie den Einstellungsmodus und wählen Sie die Dateneingabe.
 - In diesem Modus können der Werkstattname, die Adresse und die Telefonnummer über die Bildschirmtastatur eingegeben werden. Um die Ergebnisse zu speichern, drücken Sie auf das Datenträgersymbol in der oberen rechten Ecke der virtuellen Tastatur. Diese Informationen werden beim Drucken auf den Testergebnissen angezeigt.
- Um das Kennzeichen, die VIN oder die Kundennummer einzugeben, wählen Sie im Hauptmenü das Detailingabesymbol aus, und klicken Sie auch auf das Datenträgersymbol auf der virtuellen Tastatur. Ein Barcode-Scanner (separat erhältlich) kann an Scan-Barcodes angeschlossen werden und die Barcode-Nummer direkt auf den Beleg drucken.
- Um Datum & Uhrzeit zu ändern, wählen Sie den Einstellungsmodus aus und wählen Sie Datum & Uhrzeit.
- Um den Ton ein oder auszuschalten, wählen Sie den Einstellungsmodus und wählen Sie Ton.
- Um einen Test durchzuführen, wählen Sie das 'Stethoskop Symbol':
 - Dann können Autos, Motorrad oder LKW-Modi ausgewählt werden. Hinweis für 24V-Batterien: Sie müssen getrennt und nur einzeln in 12V getestet werden.
 - Wählen Sie für einen Batterietest den Batteriemodus aus und wählen Sie den entsprechenden Batterietyp aus und geben Sie die Spezifikationen der Batterie (CCA, EN1 usw.) ein.
 - Befolgen Sie für einen Alternator-Test die Anweisungen auf dem Tester.
 - Befolgen Sie für einen Startertest die Anweisungen auf dem Tester.
 - Befolgen Sie für einen Masse-test die Anweisungen auf dem Tester.
 - Sobald die Tests abgeschlossen sind, werden die Ergebnisse angezeigt und können durch Drücken der Drucktaste auf dem Tester gedruckt werden.
- Um gespeicherte Ergebnisse anzuzeigen, wählen Sie im Hauptmenü das Symbol "Vergrößerungsglas" aus.
 - Navigieren Sie durch die Ergebnisse, um jeden Test anzuzeigen, und drucken Sie ggf. die Ergebnisse
- Um gespeicherte Testdaten zu entfernen, wählen Sie einfach das Symbol "Dustbin" im Einstellungs Menü aus.
 - Navigieren Sie durch die Tests und löschen Sie jeden Test bei Bedarf.



10. Die SD-Karte kann auf der rechten Seite des Testers eingelegt oder entfernt werden. Bitte stellen Sie sicher, dass Sie es auf den Kopf legen, wie auf dem Tester angegeben. Zwingen Sie niemals die Karte im Steckplatz. Um es zu entfernen, verwenden Sie einen kleinen Stift, um darauf zu drücken.

Einschalten des Geräts

Zum Einschalten des T13 müssen die Klemmen an die Batterieklemmen angeschlossen werden. Schalten Sie den T13 ein, indem Sie die rote Klemme an die positive (+) Klemme und die schwarze Klemme an die negative Klemme (-) anschließen. Der T13 zeigt die Batteriespannung an und geht dann zum Startbildschirm, sobald eine Taste gedrückt wird.



Willkommensbildschirm



Home Screen

Durchführen eines Batterietests

Wenn ein Fahrzeug läuft, trägt die Batterie eine Oberflächenladung. Um die Batterie richtig zu testen, muss die Oberflächenladung entfernt werden, indem die Scheinwerfer 30 Sekunden lang mit ausgeschaltetem Motor eingeschaltet werden. Lassen Sie die Batterie mit der Zündung mindestens 60 Sekunden ruhen, bevor Sie die Batterie testen.

Hinweis: Der maximale Kurbelstrom einer im Motorradmodus getesteten Batterie beträgt 600A Der maximale Kurbelstrom einer im Automodus getesteten Batterie beträgt 2000A Im Motorradmodus, nur der Batterietest ist verfügbar. Im Automodus sind alle Tests verfügbar.



Sie die Richtungstasten, um <Test> und drücken Sie die



Sie die Richtungstasten, um das Fahrzeug



Sie die Richtungstasten, um den Test



Wählen Sie den entsprechenden Batterietyp aus

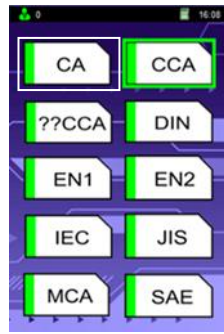

Wählen Sie die Testmessung entsprechend Ihrer Batterie



Sie die Pfeile, um den Wert um +/- 5 und um +/- 100 zu ändern

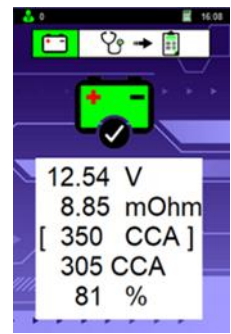

Drücken Sie die Drucktaste auf dem Tester, um die Ergebnisse zu drucken.

Interpretation der Batterietestergebnisse:



← Blinken

Die Batterie ist in gutem Zustand



← Blinken

Der Akku ist in Ordnung, muss aber wieder



← Blinken

Die Batterie ist nicht mehr gesund und muss ausgetauscht werden



← Blinken

Sterben Batterie muss wieder aufgeladen und getestet werden, um die endgültigen Ergebnisse zu bestätigen.

Testergebnisse: (Beispielwerte)

Volt:	12.68V	Zeigt den Ladezustand [SOC] der getesteten Batterie an)
Batteriebewertung:	320 CCA	Zeigt die Batteriekapazität Nennleistung an
Verfügbare Leistung:	286 CCA	Zeigt die tatsächlichen Leistungen.
Interner Widerstand:	9,45 mOhm	Zeigt den Innenwiderstand der getesteten Batterie an.
LIFE:	89 %	Gibt die Batterielebensdauer [Gesundheit] in Prozent an.
		Wenn er unter 50 % fällt, zeigt der Tester an, dass die Batterie ausgetauscht werden muss.

Hinweis für den Innenwiderstand: Im Durchschnitt liegt der Normalbereich zwischen 2-4 mOhm bis 10-15 mOhm, um als gut angesehen zu werden. Oberhalb dieser Werte gilt eine Batterie als gealtert oder sulfatiert. Motorradbatterien können einen höheren Innenwiderstand haben und aufgrund ihrer niedrigeren CCA-Werte immer noch als gut angesehen werden. Bitte beachten Sie immer die vom Batteriehersteller angegebenen Werte.



Hinweis: Oberflächenladung

erkannt Wenn der Tester eine Oberflächenladung erkennt, muss das folgende Verfahren befolgt werden. Sobald sie abgeschlossen ist, fahren Sie mit dem Test fort.

Zündschlüssel in ON-Position

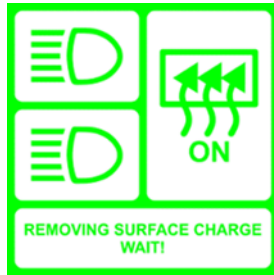

Drehzündung Stolton Position



Scheinwerfer – [Low & High]: Auf

Scheinwerfer [Niedrig & Hoch]: AUS

Hinweis: Weak-Terminalverbindungen erkannt,

Wenn die Verbindung zur Batterie nicht ausreichend sicher ist, um einen Test genau durchzuführen. Der Tester zeigt das folgende Symbol auf dem Bildschirm an. Trennen Sie den Tester von der Batterie, entfernen Sie potenziellen Schmutz von den Klemmen und verbinden Sie es wieder fest. Wiederholen des Testvorgangs.

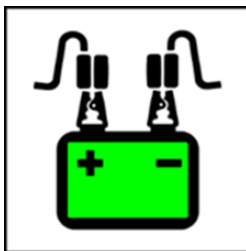

Abwechselnd blinken

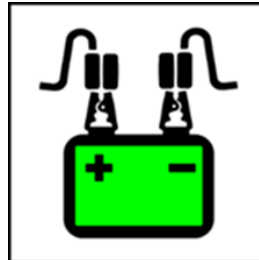

Hinweis: Niedriger Ladezustand (>75%),

Temperaturladungsauswahl Wenn der Tester erkennt, dass die Batterie entladen ist, fordert er die Temperaturauswahloption auf

(-) 0°C und

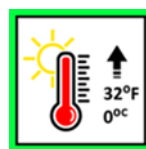
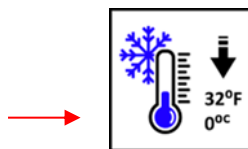

(+) 0°C und höher

Hinweis: Niedriger Ladezustand (>75%),

Ladestatusauswahl Wenn der Tester erkennt, dass die Batterie entladen ist, fordert er die Option für die Ladestatusauswahl au

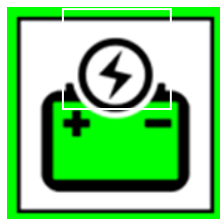

Nach Ladungsauswahl

Vor der Ladungsauswahl





Durchführen eines Schnelltests: Starter

Sobald die Klemmen angeschlossen sind, folgen Sie den Anweisungen auf dem Bildschirm, um einen Startertest durchzuführen.

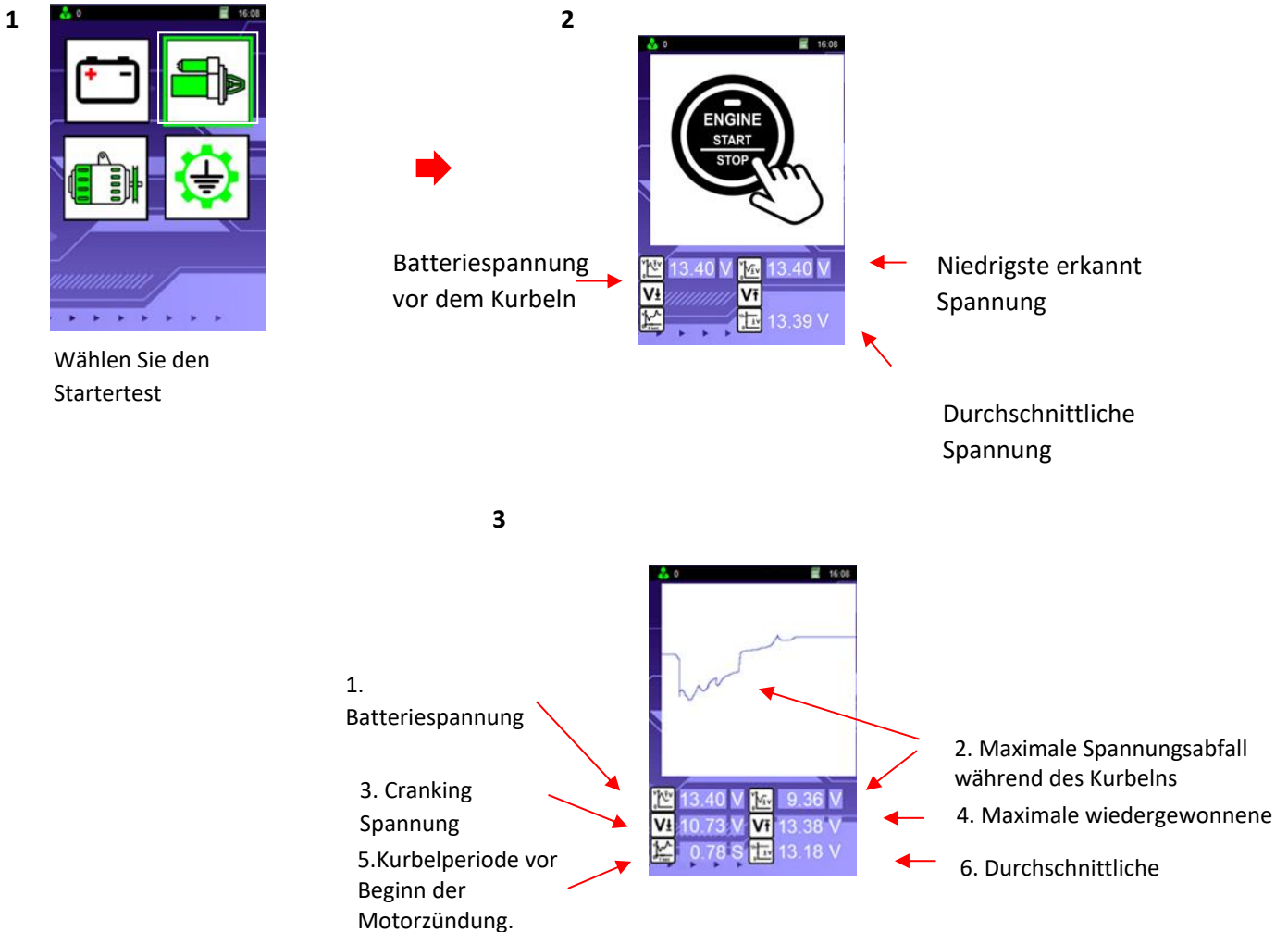

Interpretation der Starter-Test-Ergebnisse:

1. Batteriespannung vor dem Kurbeln: **13.40 V**
Zeigt den Ladezustand (SOC) der Batterie an, bevor der Motor gekurbelt wird.
2. Maximaler Spannungsabfall beim Kurbeln: **9.36 V**
Zeigt den erfassten Spannungsabfall an, wenn der Starter den Motor aufgrund der Last beim Starten kurbelt.
3. Kurbelspannung: **10.73 V**
Gibt die tatsächliche Kurbelspannung an. Wenn die Spannung unter 9,6 V für 12V-System oder unter 19,2V für 24V-System fällt, bedeutet das, dass die Batterie schwach ist und sich dem Ende ihrer Lebensdauer beeilt.
4. Maximale wiedergewonnene Spannung: **13.38 V**
Zeigt die höchste Steigspannung an, bevor sie in den Ladevorgang geht, während der Motor läuft.
5. Kurbelzeit vor Motorzündung: **0.78S**
Gibt den Zeitraum (in Sekunden) beim Kurbeln an, bevor der Motor startet, und bestimmt den Zustand der Batterie. Je kürzer die Kurbelzeit, desto besser der Zustand der Batterie. Schwache Batterien werden länger dauern, um den Motor zu starten.



6. Durchschnittliche wiedergewonnene Spannung: **13.18 V**

Diese Spannung, die während der Wiederherstellungsphase nach der Zündung erfasst wird, bevor sie zum Aufladen von Volt geht. Es zeigt, wie gut die Batterie auf ihrer Spannungsrückgewinnung im Vergleich zum Zustand der Ladung (SOC) Spannung ist.

Durchführung eines Alternortests:

Dieser Test sollte nur mit ausgeschaltetem Motor des Fahrzeugs, getriebehaft in NEUTRAL oder PARK und mit angezogener Feststellbremse durchgeführt werden.

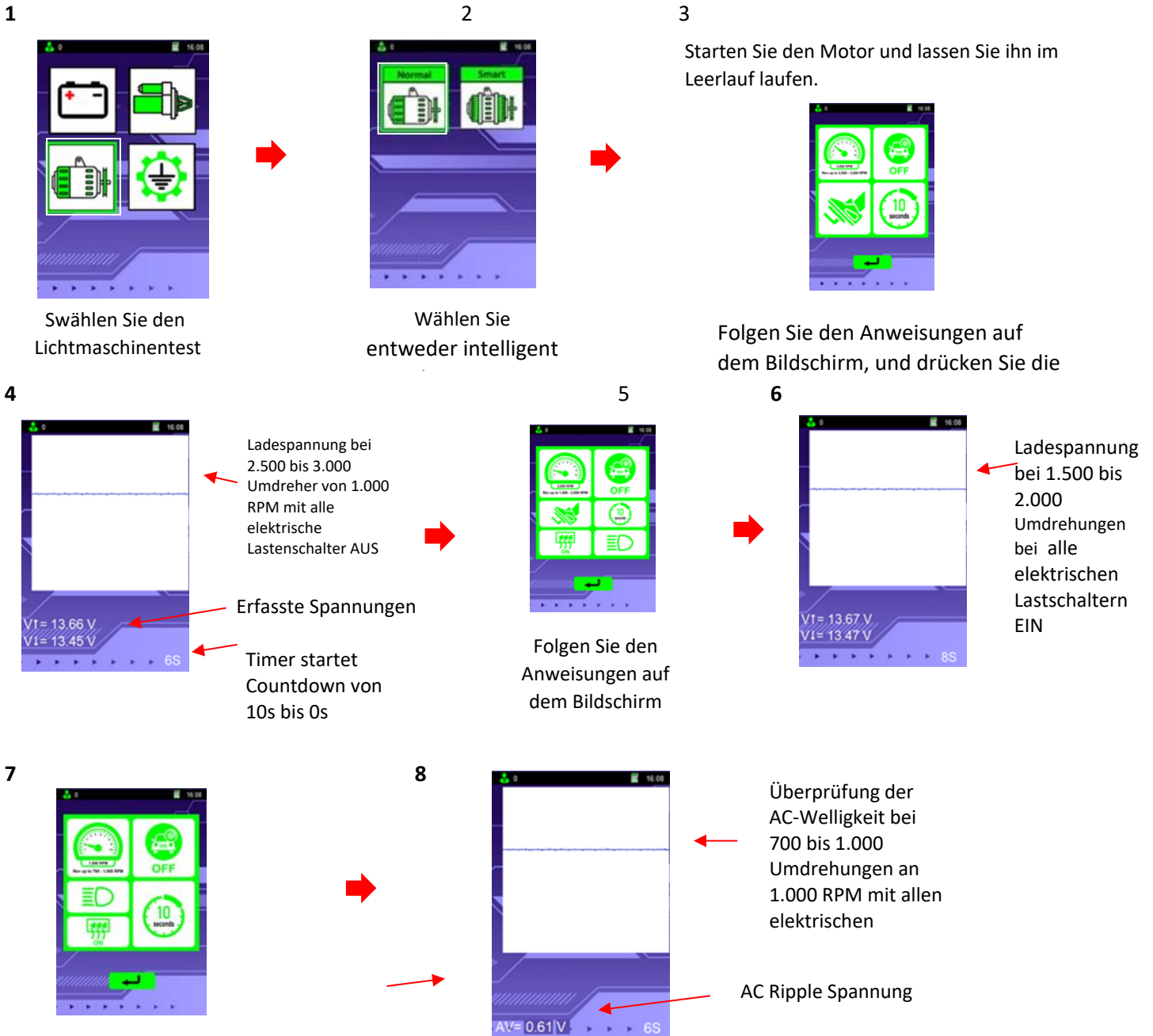

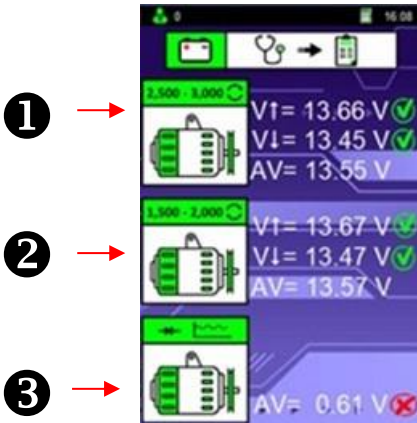

Symbole

V↑: Maximale Spannung (V max)

V↓: Mindestspannung (V min)

Av: Durchschnittliche Spannung

Die aufgezeichneten Ergebnisse können mit den nachstehenden Tabellen verglichen werden, um den Zustand der Lichtmaschine anzuzeigen, und sind in drei Abschnitte eingeteilt.

1. Ohne elektrischen Belastungstest (2.500 bei 3.000 RPM)

1.5K ~ 2.0K tr/min Ohne Ladung	12V Spannungsgrenzen der Lichtmaschine		24V Generator Spannungsgrenze	
	Normal	Smart	Normal	Smart
V ↑	<15,0V	<16,2V	<30,0V	<32,4V
V ↓	>13,3V	>12,4V	>26,6V	>24,8V

2. Mit elektrischem Belastungstest (1.500 bei 2.000 RPM)

1.5K ~ 2.0K tr/min Ohne Ladung	12V Spannungsgrenzen der Lichtmaschine		24V Generator Spannungsgrenze	
	Normal	Smart	Normal	Smart
V ↑	<13.8V	<12.4V	<27.6V	<24.8V
V ↓	>12.6V	>12.0V	>25.2v	>24.0V

3. Dioden AC Ripple Test mit Last (Idling-Geschwindigkeit: 700 x 1.000 RPM)

Die AC-Welligkeit der Lichtmaschine wird überprüft, um festzustellen, ob sie innerhalb eines Durchschnitts wert ist von 0,5V-Grenze. Wenn eine der Dioden defekt ist, erzeugt die AC-Welligkeit höher als die akzeptierte 0,5V. Anzeige, dass die Lichtmaschine nicht richtig funktioniert.

Um die Ergebnisse zu drucken, drücken Sie das Druckersymbol auf dem Tester. Durch Drücken der Rückgabetaste werden die Tests beendet.



Durchführen eines Bodentests:

With the engine OFF, connect the clamps to the battery terminals.



Sie sterben Richtungstasten, um den Bodentest



Dieser Bildschirm zeigt an, dass die negative Klemme am Chassis oder Motor befestigt muss.



Testen in Bearbeitung

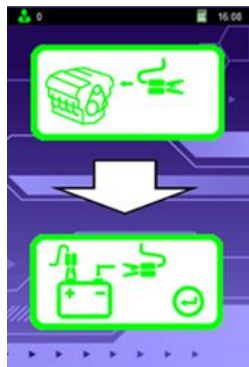

Dieser Bildschirm zeigt an, dass die negative Klemme wieder an der negativen Klemme der Batterie befestigt muss.



Testen in Bearbeitung



Testergebnis, die Bodenverbindung angibt, ist gut.

Blinken

Widerstandsmessung



Testergebnis, die Bodenverbindung angibt, ist nicht gut.

Blinken

Widerstandsmessung



Testergebnis nicht schlüssig, wiederholen Sie den Test.

Blinken

Kein Widerstand Lesen
Widerstand nicht erkannt



Detaileintrag:

Insbesondere Kundeninformationen einzugeben, bevor ein Test durchgeführt wird, Zugriff auf den Detailingabemodus im Hauptmenü.

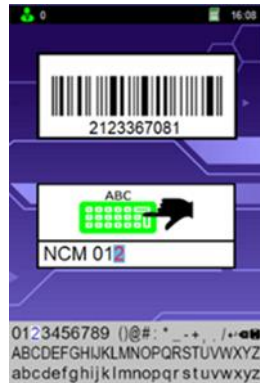

Scannen Sie mit dem optionalen Barcode-Scanner den Batteriecode und die Details werden im Barcode-Feld angezeigt.

Verwenden Sie die Richtungstasten, um die Kundeninformationen wie Name, Kennzeichen oder VIN einzugeben. Diese Informationen betiteln dann die Testergebnisse im Speicher des Geräts und werden nach den Drucken auf den Testergebnissen

Sie sterben Richtungstasten, um Detaileintrag und drücken Sie den

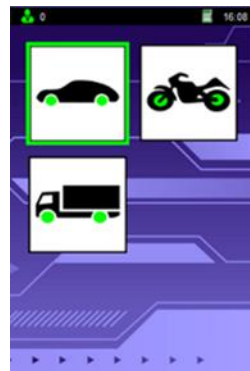

Fahren Sie mit den Tests fort, wie in den obigen Abschnitten, Batterietest, Startertest, Alternatortest, Bodentest.

Workshop-Informationseintrag:

Um den Namen, die Adresse und die Kontaktinformationen des Workshops einzugeben, greifen Sie auf das Einstellungsmenü zu und wählen Sie den Dateneingabemodus aus.

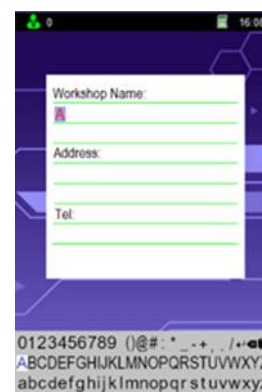
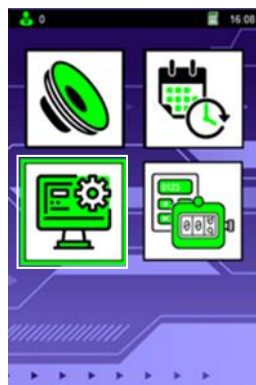

Sie sterben Richtungstasten, um <Setup> und drücken

Verwenden Sie die Richtungstasten, um "Datum & Zeit" und drücken Sie den Eingabegeschmack"

Sie die Richtungstasten, um die daten einzugeben.

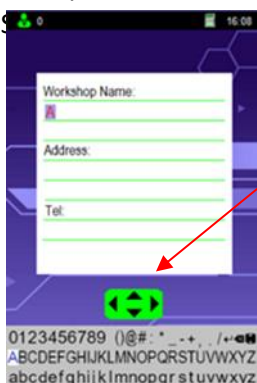

Wenn Sie zwischen Denlinien wechseln, wählen Sie die "Rückgabe"-Taste auf der Bildschirmtastatur aus. Sobald das "Return"-Symbol angezeigt wird, wird Sie die Nach-/Abwärtstasten, um die Zeilen zu wechseln.

Sobald die Eingabe abgeschlossen ist, wählen Sie das Symbol "Speichern" auf der Bildschirmtastatur aus und drücken Sie die



Session Counter Modus:

1. Wenn der Modus "Counter" ausgewählt ist, wird die Gesamtzahl der durchgeführten Tests in jeder Kategorie angezeigt. Der Total Counter kann nicht auf null zurückgesetzt werden, jedoch kann der Session Counter zurückgesetzt werden.

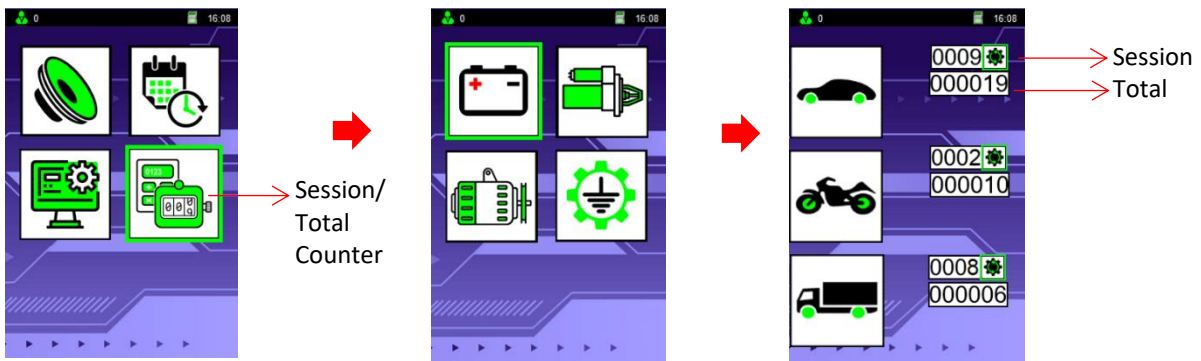

Wählen Sie mit den Navigationstasten den Modus "Counter" und drücken Sie dann die Eingabetaste [↵].

Wählen Sie mit den Navigationstasten das Symbol "Akku" und drücken Sie dann die Eingabetaste [↵].

Verwenden Sie die ▲ oder ▼ Tasten, um den Fahrzeugtyp auszuwählen, und drücken Sie dann die Eingabetaste [↵], um den Counter auf null zurückzusetzen.

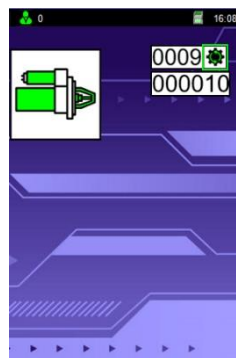

Verwenden Sie die Navigationstasten, um das Symbol " Starter" auszuwählen, und drücken Sie dann die Eingabetaste [↵].

Drücken Sie die Eingabetaste [↵], um den Counter auf null zu setzen.

Verwenden Sie die Navigationstasten, um das Symbol Generator auszuwählen, und drücken Sie dann die Eingabetaste [↵].

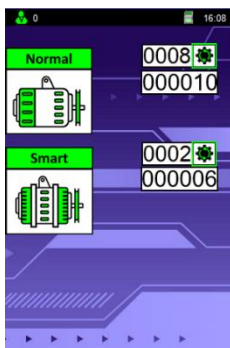

Verwenden Sie die Tasten ▲ oder ▼, um den Generatortyp auszuwählen, und drücken Sie dann die Eingabetaste [↵], um den Counter auf null zurückzusetzen.

Wählen Sie mit den Navigationstasten das Massensymbol und drücken Sie dann die Eingabetaste [↵].

Drücken Sie die Eingabetaste [↵], um den Counter auf null zu setzen.



User Manual

The T13 Advanced Battery tester operates on 12V and 24V systems and is able to perform four tests:

- Battery Test:** Analyses the battery condition using a microprocessor-controlled testing method (12V Batteries).
- Ground Test:** Analyses the condition of the electrical return circuit (12V System Only).
- Starter Test:** Checks the cranking effectiveness of the battery to predict when the battery will fail to crank a vehicle (12V/24V System).
- Alternator Test:** This test checks the alternator's condition by testing it under different loads and performing a diode ripple test (12V/24V System).

Operating Procedure:

11. Connect the T13's clamps to the battery terminals to power it on. The battery voltage will appear on the screen.
12. Press any key to advance to the home screen. Once on the home screen several modes are available:

a. Detail Entry	b. Test	c. Memory storage	d. Settings
-----------------	---------	-------------------	-------------
13. To enter workshop information, select the settings mode and chose data input
 - a. Once in this mode the workshop name, address and telephone number can be entered using the on-screen keyboard. To save the results, press on the disk symbol on the top right corner of the virtual keyboard. This information will appear on the test results when printed.
14. To enter the license plate, VIN or customer number, select the Detail Entry symbol in the main menu, and the also click on the disk symbol on the virtual keyboard. A barcode scanner (sold separately) can be connected to scan barcodes and print the barcode number on the receipt directly.
15. To change the Date & Time, select the settings mode and chose Date & Time
16. To turn the Sound On/Off, select the settings mode and chose Sound
17. To perform a Test, select the 'stethoscope symbol':
 - a. Car, motorcycle or truck modes can then be selected. Note for 24V batteries: they must be separated and be tested individually in 12V only.
 - b. For a battery test, select the battery mode and chose the appropriate battery type and enter the specifications of the battery (CCA, EN1 etc.)
 - c. For an Alternator test, follow the instructions displayed on the tester
 - d. For a Starter test, follow the instructions displayed on the tester
 - e. For a Ground test, follow the instructions displayed on the tester
 - f. Once the test(s) is(are) complete the results will display and can be printed by pressing the print button on the Tester



18. To view stored results, select the 'Magnifying Glass' symbol on main menu
 - a. Navigate through the results to view each test and if necessary, print the results
19. To remove stored test data, just select the 'Dustbin' symbol in the settings menu.
 - a. Navigate through the tests and delete each test as necessary
20. The SD card can be inserted or removed on the right side of the tester. Please make sure you insert it upside down as indicated on the tester. Never force the card in the slot. To remove it, use a small pin to press on it.

Powering on the Device

To power on the T13 the clamps must be connected to the battery terminals. Turn the T13 on by connecting the red clamp to the positive (+) terminal and the black clamp to the negative terminal (-). The T13 will display the battery voltage and will then proceed to the home screen once a key is pressed.



Welcome Screen

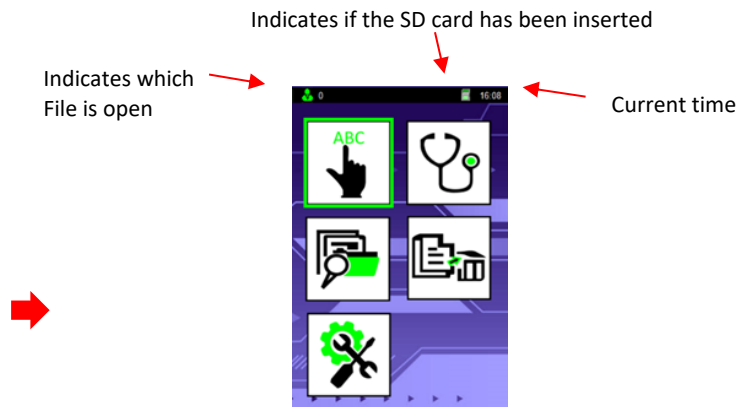

Home Screen

Performing a Battery Test

When a vehicle has been running the battery will carry a surface charge. In order to correctly test the battery, the surface charge must be removed by turning the headlights ON for 30 seconds with the engine off. Leave the battery at rest with the ignition OFF for at least 60 seconds before testing the battery.

Note: The maximum cranking current of a battery tested in motorcycle mode is 600A
The maximum cranking current of a battery tested in car mode is 2000A
In motorcycle mode, only the battery test is available. In car mode, all tests are available.



Use the directional keys to select <Test> and press enter

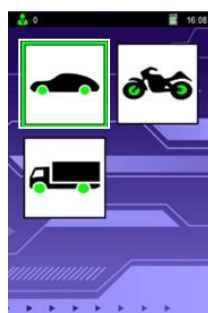

Use the directional keys to select the vehicle



Use the directional keys to select the required test

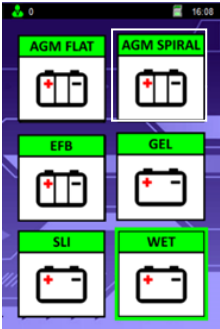

Select the appropriate battery type



Select the test measure according to your battery



Use the arrows to change the value by +/- 5 and by +/- 100

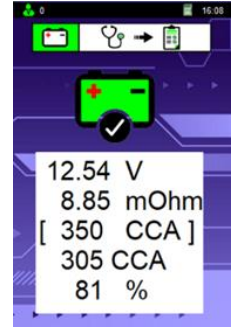

Press the print button on the Tester to print the results.

Interpretation of the battery test results:



The battery is in good condition



The battery is OK but needs to be recharged (State



The battery is no longer healthy and must be replaced



The battery needs to be recharged and tested again to confirm the final results.

Test Results: (example values)

Volts:	12.68V	Indicates the State of Charge [SOC] of the tested battery)
Battery Rating:	320 CCA	Indicates the battery capacity rated output
Power available:	286 CCA	Indicates the actual power output.
Internal Resistance:	9.45 mOhm	Indicates the internal resistance of the tested battery.
LIFE:	89 %	Indicates battery life expectancy [Health] in percentage. If it falls below 50 %, the tester will indicate that the battery must be replaced.

Note for the internal resistance: On average normal range is between 2-4 mOhm to 10-15 mOhm to be considered good. Above these values a battery is considered aged or sulphated. Motorcycle batteries may have a higher internal resistance and still be considered good due to their lower CCA values. Please always refer to the values given by the battery manufacturer.



Note: Surface charge detected

If the Tester detects a surface charge, the following procedure must be followed. Once complete proceed with the test.

Turn ignition key to ON position

Headlights – [Low & High] turned: ON

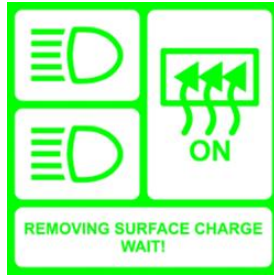

Turn ignition key OFF position

Headlights [Low & High]: OFF

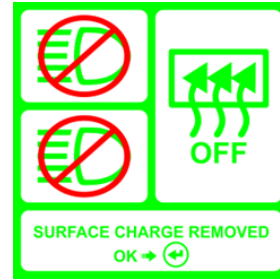

Note: Weak terminal connections detected

When the connection to the battery is insufficiently secure to accurately perform a test. The tester will display the following icon on the screen. Disconnect the tester from the battery, remove potential dirt from the terminals and reconnect it firmly. Repeat the test procedure.

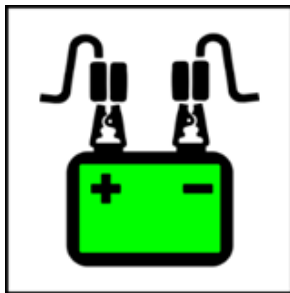

Flashing alternately

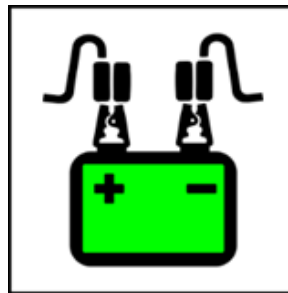

Note: Low state of charge (>75%), temperature selection

If the Tester detects that the battery is discharged it will prompt the temperature selection option

(-) 0°C and below

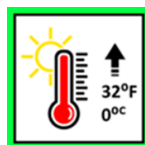
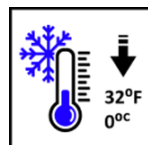

(+) 0°C and above

Note: Low state of charge (>75%), charge status selection

If the Tester detects that the battery is discharged it will prompt the charge status selection option

Before charge selection

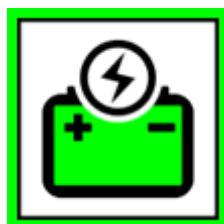

After charge selection





Performing a Quick Test: Starter

Once the clamps are connected follow the on-screen instructions to perform a starter test.

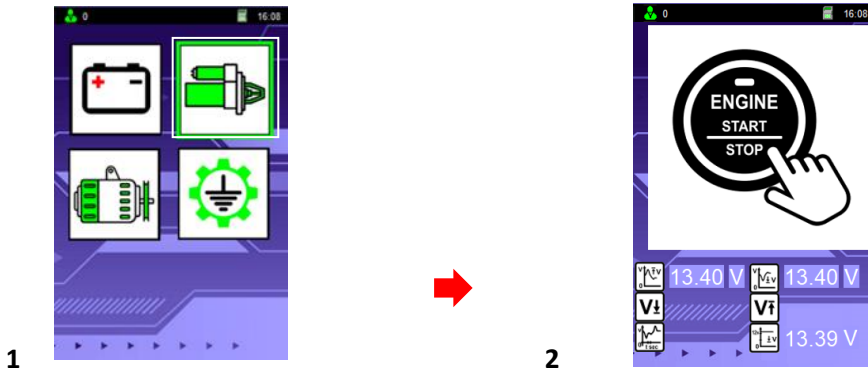

Select the starter test

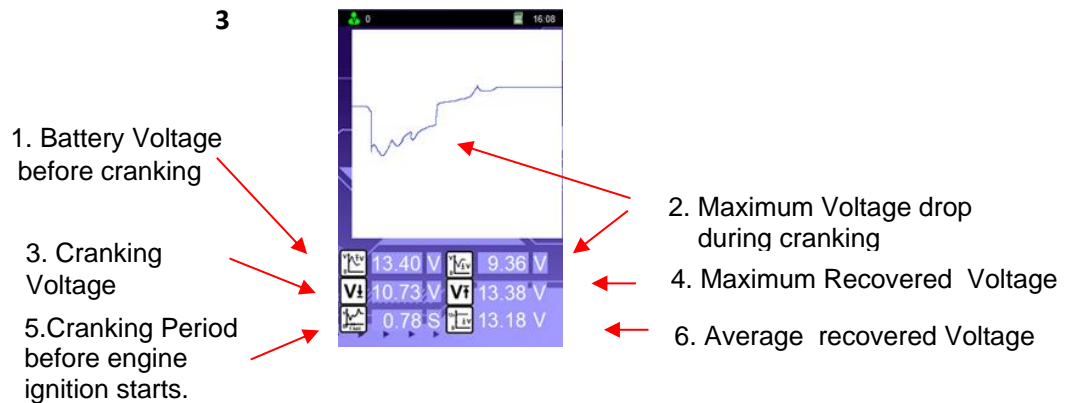

Interpretation of the Starter Test results:

7. Battery Voltage before cranking: **13.40 V**
Indicates the state of charge (SOC) of the battery before cranking the engine.
8. Maximum voltage drop during cranking: **9.36 V**
Indicates the captured voltage drop when the Starter crank the engine due to the load during starting.
9. Cranking Voltage: **10.73 V**
Indicates the actual cranking voltage. If the voltage drops below 9.6V for 12V system or below 19.2V for 24V system that means that the battery is weak and is coming to the end of its operating life.
10. Maximum Recovered Voltage: **13.38 V**
Indicates the highest climb voltage before going into the charging while the engine is running.
11. Cranking period before engine ignition starts: **0.78S**
Indicates the period (in seconds) during cranking before the engine starts and determines the condition of the battery. The shorter the cranking time the better the condition of the battery. Weak batteries will take longer to start the engine.
12. Average recovered voltage: **13.18 V**
This voltage captured during recovery stage after ignition before going to charging volts. It tells how good the battery is on its voltage recovery compared to the state of charge (SOC) voltage.



Performing an Alternator Test:

This test should only be performed with the vehicle's engine turned OFF, its transmission in NEUTRAL or PARK and with the parking brake applied.

1



Select the alternator test

2



Select either smart or normal alternator

3

Start the engine and leave it running at idle.



Follow the on-screen instructions, and press Enter

4

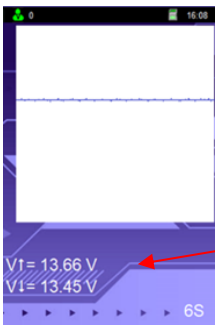

Charging voltage at 2,500 ~ 3,000 RPM with all electrical loads switch OFF

Captured voltages

Timer starts to countdown from 10s to 0s

5



Follow the on-screen instructions

6

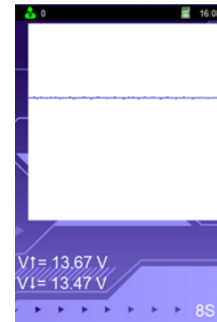

Charging voltage at 1,500 ~ 2,000 RPM with all electrical loads switch ON

7

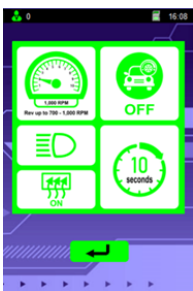

8

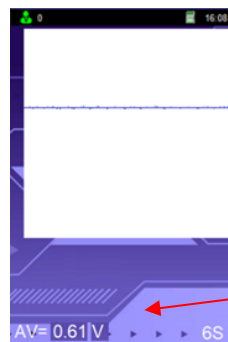

Checking the AC ripple at 700 ~ 1,000 RPM with all electrical loads switch ON

AC Ripple Voltage

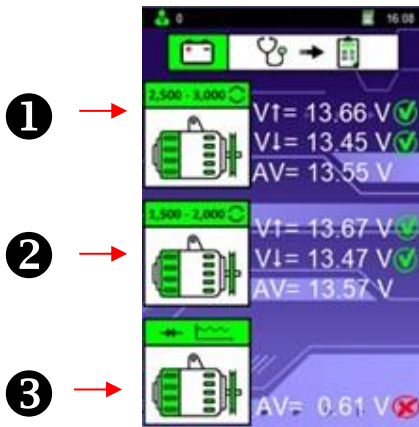

Symbols

- V↑: Maximum Voltage (V max)
- V↓: Minimum Voltage (V min)
- AV: Average Voltage

The recorded results can be compared with the tables below to indicate the state of the alternator, and are categorized into three sections

1. Without Electrical Load Test (2,500 ~ 3,000 RPM)

2.5K ~ 3.0K RPM Without Load	12V Alternator Volt Limits		24V Alternator Volt Limits	
	Normal	Smart	Normal	Smart
V↑	< 15.0V	< 16.2V	< 30.0 V	< 32.4V
V↓	> 13.3V	> 12.4V	> 26.6 V	> 24.8 V

2. With Electrical Load Test (1,500 ~ 2,000 RPM)

1.5K ~ 2.0K RPM With Load	12V Alternator Volt Limits		24V Alternator Volt Limits	
	Normal	Smart	Normal	Smart
V↑	> 13.8V	> 12.4V	> 27.6 V	> 24.8V
V↓	> 12.6V	> 12.0V	> 25.2 V	> 24.0 V

3. Diode AC Ripple Test with Load (Idling speed: 700 ~ 1,000 RPM)

The AC ripple of the alternator is checked to see if it is within an average of the 0.5V limit. If one of the diodes is faulty, the AC ripple will produce higher than the accepted 0.5V. Indicating that the alternator is not functioning correctly.

To print the results, press the printer symbol on the tester. Pressing the return key will exit the tests.



Performing a Ground Test:

With the engine OFF, connect the clamps to the battery terminals.



Use the directional keys to select the ground test



This screen indicates that the negative clamp must be attached to the chassis or engine.



Testing in progress

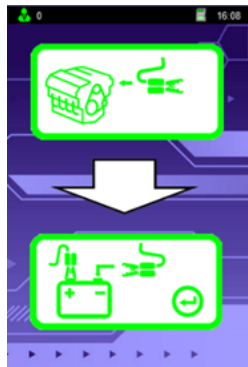

This screen indicates that the negative clamp must be attached back onto the battery's negative terminal



Testing in progress



Flashing

Resistance reading

Test result indicating the ground connection is good.



Flashing

Resistance reading

Test result indicating the ground connection is not good.



Flashing

No resistance reading
Resistance not detected

Test result inconclusive, repeat the test.



Detail Entry:

To enter particular client information before performing a Test, access the detail entry mode on the main menu.

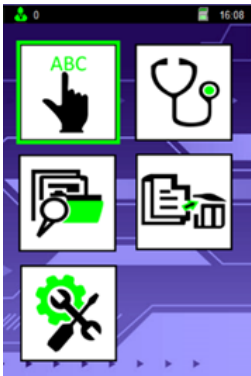

Using the optional barcode scanner, scan the batteries code and the details will appear in the barcode field.

Use the directional keys to input the customers information such as name, license plate or VIN. This information will then title the test results in the device's memory as well as appearing on the test results once printed.

Use the directional keys to select Detail entry and press enter



Proceed with the required tests as explained in the above sections, Battery Test, Starter Test, Alternator Test, Ground Test.

Workshop information entry:

To enter the name, address and contact information of the workshop access the settings menu and select the data input mode.

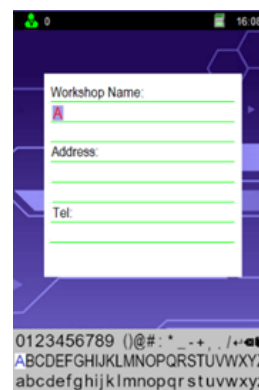
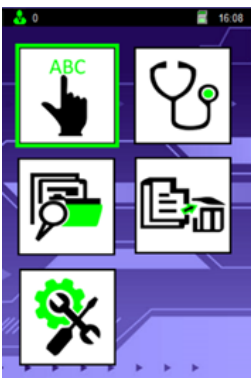

Use the directional keys to select <Setup> and press enter

Use the directional keys to select <Date & Time> and press enter

Use the directional keys to input the required data.



When moving between lines, select the 'return' key on the on-screen keyboard. Once the 'return' icon appears, use the up/down keys to move between lines. Once input is complete select the 'Save' icon on the on-screen keyboard and press enter.



Session Counter Mode:

1. When the Counter mode is selected, the total number of tests conducted tester will be displayed in each category. The total counter cannot be reset to zero however the session counter can be reset.

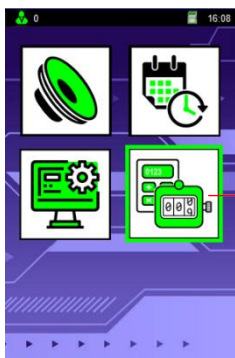

Session/
Total
Counter

Use the directional keys to select the Counter mode and then press Enter [↵].



Use the directional keys to select the Battery icon and then press Enter [↵].



Session
Total

Use the ▲ or ▼ keys to select the vehicle type and then press Enter [↵] to reset the Counter to zero.



Use the directional keys to select the Starter icon and then press Enter [↵].

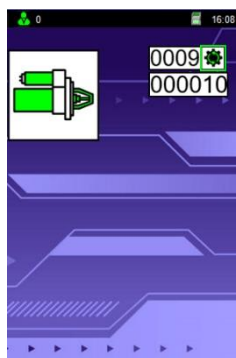

Press Enter [↵] to reset the Counter to zero.



Use the directional keys to select the Alternator icon and then press Enter [↵].

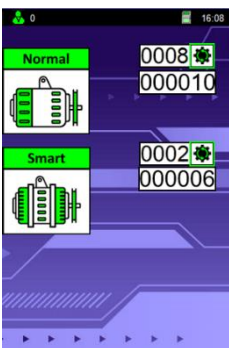

Use the ▲ or ▼ keys to select the alternator type and then press Enter [↵] to reset the Counter to zero.



Use the directional keys to select the Ground icon and then press Enter [↵].



Press Enter [↵] to reset the Counter to zero.



Manuel de l'utilisateur

Le testeur de batterie avancé T13 fonctionne sur des systèmes 12V et 24V, il est capable de faire ces quatre tests :

Test de Batterie :	Analyse l'état de la batterie à l'aide d'une méthode de test contrôlée par un microprocesseur (Batteries 12V)
Test de la Mise à la Terre :	Analyse l'état du circuit de retour électrique (système 12V uniquement)
Test de Démarrage :	Vérifie l'efficacité de démarrage de la batterie pour prédire quand la batterie ne parviendra pas à démarrer un véhicule (systèmes 12V / 24V).
Test de l'Alternateur :	Ce test vérifie l'état de l'alternateur en le testant sous différentes charges et en effectuant un test d'ondulation de diode (systèmes 12V/24V).

MODE OPERATOIRE :

1. Connectez les pinces du T13 aux bornes de la batterie pour la mettre sous tension. La tension de la batterie apparaîtra à l'écran.
2. Appuyez sur n'importe quel touche pour passer à l'écran d'accueil. Une fois sur l'écran d'accueil, plusieurs modes sont disponibles :

a. Entrer des Données	b. Test	c. Mémoire du Testeur	d. Configuration
-----------------------	---------	-----------------------	------------------

3. Pour entrer des informations sur l'atelier, dans le mode Configuration choisissez la Saisie de Données
 - a. Une fois dans le mode, le nom, l'adresse et le numéro de téléphone de l'atelier peuvent être saisis à l'aide du clavier virtuel. Pour enregistrer les résultats, appuyez sur le symbole du disque dans le coin supérieur droit du clavier virtuel. Ces informations apparaîtront sur les résultats du test lors de l'impression.
4. Pour entrer la plaque d'immatriculation, le VIN ou le numéro de client, sélectionnez le symbole du Clavier dans le menu principal et cliquez également sur le symbole de la disquette sur le clavier virtuel. Un scanner de codes-barres (vendu séparément) peut être connecté pour numériser les codes-barres et imprimer directement le numéro de code-barres sur le reçu.
5. Pour modifier la date et l'heure, sélectionnez le mode Configuration et choisissez Date et heure
6. Pour activer / désactiver le son, sélectionnez le mode Configuration et choisissez Son.
7. Pour effectuer un test, sélectionnez le symbole du <<Stéthoscope>>
 - a. Le mode voiture, camion ou moto peuvent alors être sélectionnés. Remarque pour les batteries 24V : elles doivent être séparées et testées individuellement en 12V uniquement.
 - b. Pour un test de batterie, sélectionnez le mode Batterie, choisissez le type de batterie approprié et entrez les spécifications de la batterie (CCA, EN1 etc.)
 - c. Pour un test d'alternateur, suivez les instructions affichées sur le testeur
 - d. Pour un test de démarrage, suivez les instructions affichées sur le testeur
 - e. Pour un test de la mise à la terre, suivez les instructions affichées sur le testeur
 - f. Une fois le ou les tests terminés, les résultats s'affichent et peuvent être imprimés en appuyant sur le bouton d'Impression du Testeur.
8. Pour afficher les résultats enregistrés, sélectionnez le symbole de la <<Loupe>> dans le menu principal
 - a. Parcourez les résultats pour afficher chaque test, si nécessaire imprimez les résultats.



9. Pour supprimer les données de test enregistrées, sélectionnez simplement le symbole de la <<Poubelle>> dans le menu des paramètres.
 - a. Parcourez les tests et supprimez chaque test si nécessaire.
10. La carte SD peut être insérée ou retirée sur le côté droit du testeur. Veuillez-vous assurer de l'insérer à l'envers comme indiqué sur le testeur. Ne forcez jamais la carte dans la fente. Pour la retirer, utilisez une petite pointe pour appuyer sur la carte.

Mise sous Tension de l'Appareil

Pour mettre le T13 sous tension, les pinces doivent être connectées aux bornes de la batterie. Allumez le T13 en connectant la pince rouge à la borne positive (+) et la pince noire à la borne négative (-). Le T13 affiche la tension de la batterie et passe ensuite à l'écran d'accueil une fois qu'une touche est enfoncée.



Ecran de Bienvenue



Ecran d'accueil

Exécution d'un Test de Batterie

Lorsqu'un véhicule a roulé, la batterie est chargée en surface. Afin de tester correctement la batterie, la charge de surface doit être supprimée en allumant les phares pendant 30 secondes avec le moteur arrêté. Laissez la batterie au repos avec le contact coupé pendant au moins 60 secondes avant de tester la batterie.

Remarque : Le courant de démarrage maximum d'une batterie testée en mode moto est de 600A
Le courant de démarrage maximum d'une batterie testée en mode voiture est de 2000A
En mode moto, seul le test de la batterie est disponible. En mode voiture, tous les tests sont disponibles.

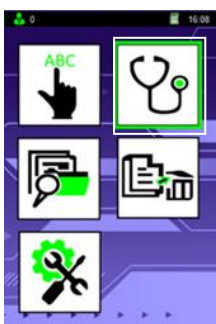

Utilisez les touches directionnelles pour sélectionner <Test> et appuyez sur Entrée

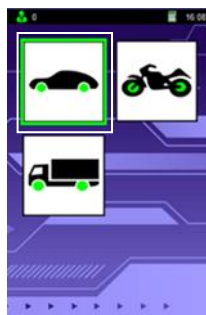

Utilisez les touches directionnelles pour sélectionner le véhicule



Utilisez les touches directionnelles pour sélectionner le test requis

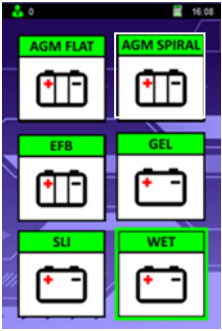

Sélectionnez le type de batterie approprié



Sélectionnez la mesure de test en fonction de votre batterie



Utilisez les flèches pour modifier la valeur de +/- 5 et par +/- 100

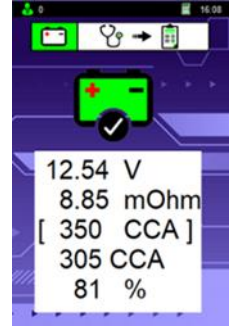

Press the print button on the Tester to print the results.

Interprétation des résultats des tests de batterie :



← Clignotant

La batterie est en bon état



← Clignotant

La batterie est OK mais doit être rechargée (l'état de charge est faible).



← Clignotant

La batterie n'est plus en bon état et doit être remplacée



← Clignotant

La batterie doit être rechargée et testée à nouveau pour confirmer les résultats finaux.

Résultats des tests : (exemples de valeurs)

Volts :	12.68V	Indique l'état de charge [SOC] de la batterie testée.
Évaluation de la batterie :	320 CCA	Indique la sortie nominale de la capacité de la batterie.
Puissance disponible :	286 CCA	Indique la puissance de sortie réelle.
Résistance interne :	9.45 mOhm	Indique la résistance interne de la batterie testée.
VIE :	89 %	Indique l'espérance de vie de la batterie [Santé] en pourcentage. Si elle tombe en dessous de 50%, le testeur indiquera qu'elle doit être remplacée.

Remarque pour la résistance interne : La plage normale moyenne se situe entre 2-4 mOhm et 10-15 mOhm pour être considérée comme bonne. Au-dessus de ces valeurs, une batterie est considérée comme âgée ou sulfatée. Les batteries de moto peuvent avoir une résistance interne plus élevée et être toujours considérées comme bonnes en raison de leurs valeurs CCA inférieures. Veuillez toujours vous référer aux valeurs fournies par le fabricant de la batterie.

Remarque : Charge de surface détectée

Si le testeur détecte une charge superficielle, la procédure suivante doit être suivie. Une fois terminée, procédez au test.

Tournez la clé de contact en position ON

Grands phares - allumés

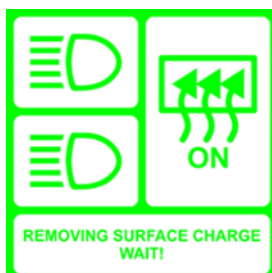

Positionner la clé de contact sur OFF



Grands phares - éteints

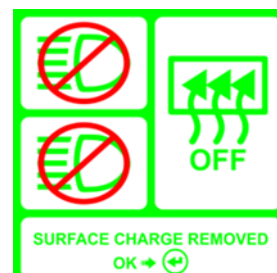



Remarque : Mauvaise connexions des pinces aux terminaux détectées

Lorsque la connexion à la batterie n'est pas suffisamment sécurisée pour effectuer un test avec précision. Le testeur affichera l'icône suivant à l'écran. Débranchez le testeur de la batterie, nettoyer les bornes et rebranchez-les fermement. Répétez la procédure de test.



Clignotant alternativement

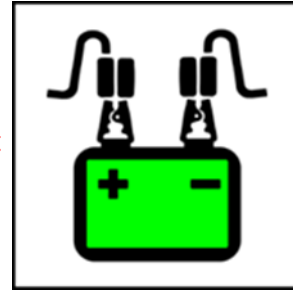

Remarque : Faible état de charge (< 75%) - sélection de la température

Si le testeur détecte que la batterie est déchargée, il demandera de sélectionner de la température ambiante.

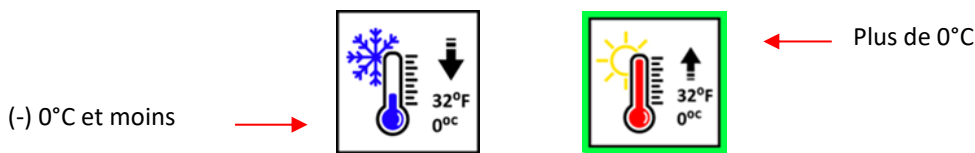

Remarque : Faible état de charge (> 75%) - sélection de l'état de charge

Si le testeur détecte que la batterie est déchargée, il demandera l'option de sélection de l'état de charge

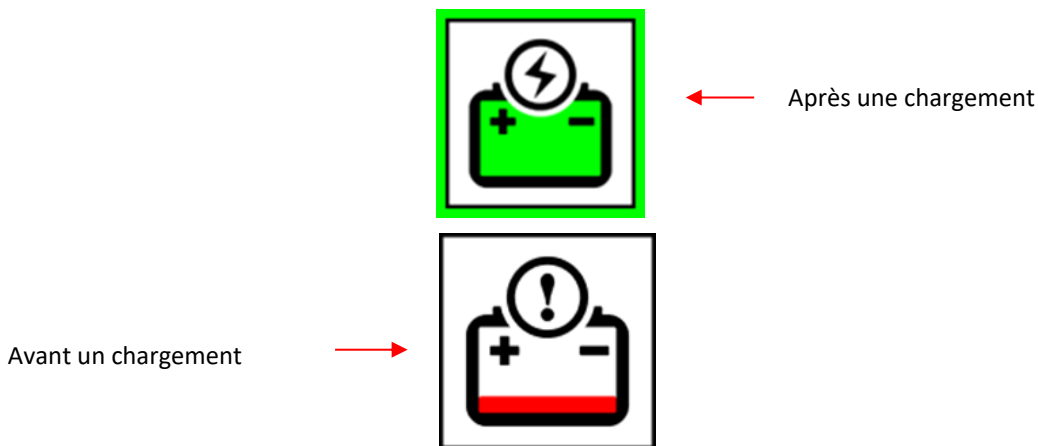



Exécution d'un test rapide : Démarreur

Une fois les pinces connectées, suivez les instructions à l'écran pour effectuer un test de démarrage.

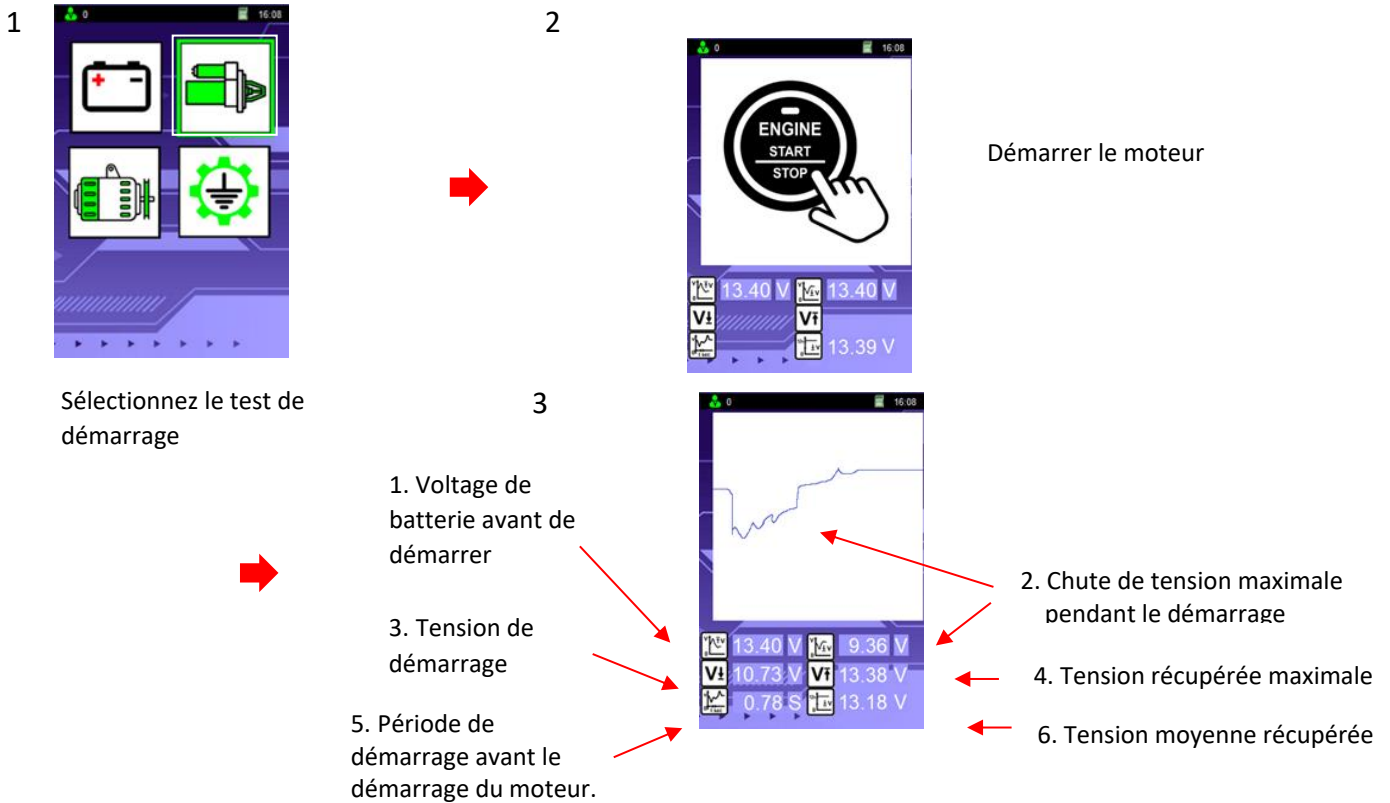

Interprétation des résultats du test de démarrage :

1. Tension de la batterie avant le démarrage : **13.40 V**
Indique l'état de charge (SOC) de la batterie avant de démarrer le moteur
2. Chute de tension maximale pendant le démarrage : **9.36 V**
Indique la chute de tension captée lorsque le démarreur démarre le moteur en raison de la charge.
3. Tension de démarrage : **10.73 V**
Indique la tension de démarrage réelle. Si la tension descend en dessous de 9.6V pour un système 12V ou en dessous de 19.2V pour un système 24V, cela signifie que la batterie est faible et arrive en fin de vie.
4. Tension maximale récupérée : **13.38 V**
Indique la tension la plus élevée avant d'entrer en mode charge pendant que le moteur tourne.
5. Temps de démarrage avant que le moteur soit allumé : **0.78S**
Indique la période (en secondes) pendant le démarrage avant le moteur soit allumé, et détermine l'état de la batterie. Plus le temps de démarrage est court, meilleur est l'état de la batterie. Les batteries faibles mettront plus de temps à démarrer le moteur.
6. Tension moyenne récupérée : **13.18 V**
Cette tension est captée pendant la phase de récupération après le démarrage. Il indique la qualité de la batterie sur sa récupération de tension par rapport à la tension d'état de charge (SOC).



Exécution d'un test d'alternateur :

Ce test ne doit être effectué que lorsque le moteur du véhicule est éteint, sa transmission en position NEUTRE ou « P » ainsi que le frein de stationnement serré.

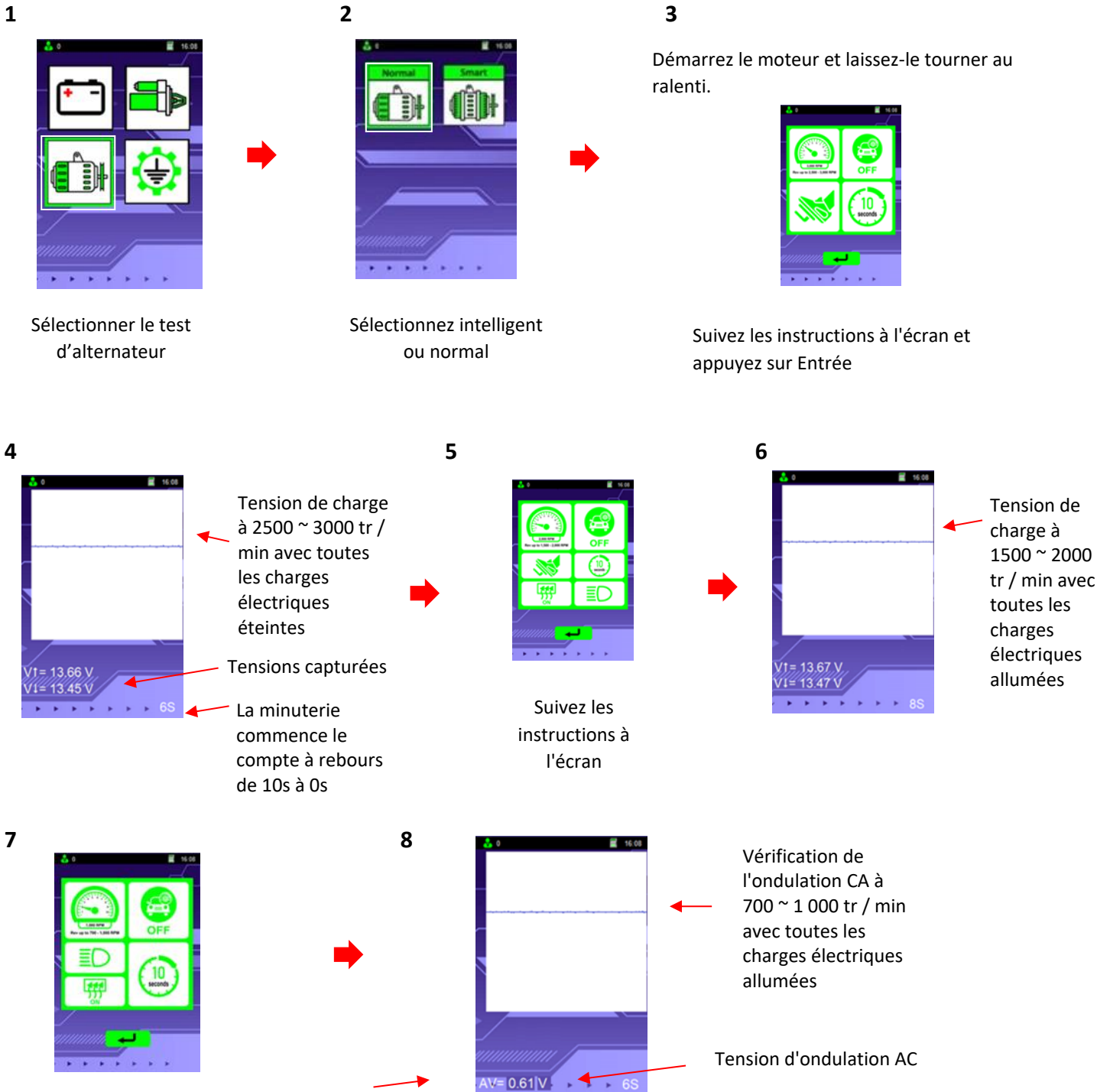

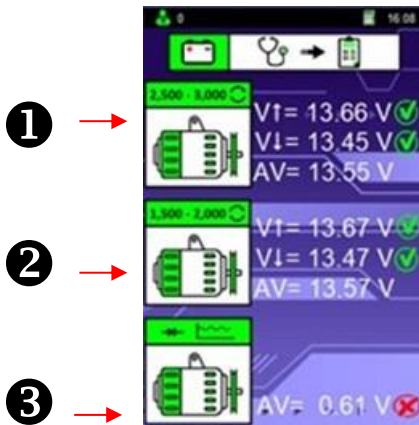

Symbols

V↑: Maximum Voltage (V max)

V↓: Minimum Voltage (V min)

AV: Moyenne Voltage

Les résultats enregistrés peuvent être comparés aux tableaux ci-dessous pour indiquer l'état de l'alternateur, et sont classés en trois sections

1. Sans test de charge électrique (2 500 ~ 3 000 tr/min)

2.5K ~ 3.0K tr/min Sans Charge	12V Limites de tension d'alternateur		24V Limite de tension d'alternateur	
	Normal	Smart	Normal	Smart
V↑	< 15.0V	< 16,2V	< 30.0V	< 32.4V
V↓	> 13.3V	> 12.4V	> 26.6v	> 24.8V

2. Avec test de charge électrique (1 500 ~ 2 000 tr / min)

1.5K ~ 2.0K tr/min Sans Charge	12V Limites de tension d'alternateur		24V Limite de tension d'alternateur	
	Normal	Smart	Normal	Smart
V↑	< 13.8V	< 12.4V	< 27.6V	< 24.8V
V↓	> 12.6V	> 12.0V	> 25.2v	> 24.0V

3. Test d'ondulation de diode AC avec charge (vitesse de ralenti : 700 ~ 1 000 tr/min)

L'ondulation AC de l'alternateur est vérifiée pour voir si elle se situe dans la moyenne de la limite de 0.5V. Si l'une des diodes est défectueuse, l'ondulation AC produira plus de 0.5V accepté. Indique que l'alternateur ne fonctionne pas correctement.

Pour imprimer les résultats, appuyez sur le symbole de l'imprimante sur le testeur. Appuyez sur la touche de retour pour quitter les tests.



Effectuer un test de mise à la terre (Ground Test):

Moteur éteint, connectez les pinces aux bornes de la batterie.



Utilisez les touches directionnelles pour sélectionner le test au sol



Cet écran indique que la pince négative doit être fixée au châssis ou au moteur.



Test en cours

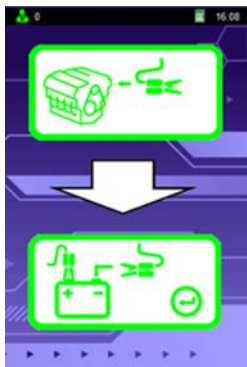

Cet écran indique que la pince négative doit être fixée à nouveau sur la borne négative de la batterie



Test en cours



Le résultat du test indiquant que la connexion à la terre est bonne.



Résultat du test indiquant que la connexion à la terre n'est pas bonne.



Résultat du test non concluant, répétez le test.

Pas de lecture de résistance
Résistance non détectée



Entrée de Données pour les Imprimer sur le Ticket :

Pour saisir des informations client avant d'effectuer un test, accédez au mode de saisie détaillée dans le menu principal.



À l'aide du scanner de codes-barres en option, scannez le code barre et les numéros du code barre apparaîtront dans le champ du code-barres et sur le reçu (scanner vendu en option).

Utilisez les touches directionnelles pour saisir les informations des clients telles que le nom, la plaque d'immatriculation ou le VIN. Ces informations titreront ensuite les résultats du test dans la mémoire de l'appareil et apparaîtront sur les résultats du test une fois imprimés. Le logo de la disquette, à droite du clavier, sert à enregistrer vos données.

Utilisez les touches directionnelles pour sélectionner Entrée détaillée et appuyez sur Entrée



Procédez aux tests requis comme expliqué dans les sections ci-dessus, Test de batterie, Test de démarrage, Test d'alternateur, Test de mise à la terre.

Saisie d'informations sur l'atelier:

Pour saisir le nom, l'adresse et les coordonnées de l'atelier, accédez au menu des paramètres et sélectionnez le mode de saisie des données.

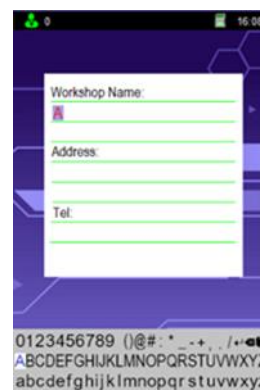

Utilisez les touches directionnelles pour sélectionner <Configuration> et

Utilisez les touches directionnelles pour sélectionner <le Clavier> et appuyez sur Entrée

Entrez les données et cliquez sur la disquette à droite du clavier pour enregistrer les données.



Lorsque vous vous déplacez entre les lignes, sélectionnez la touche «retour» du clavier à l'écran. Une fois que l'icône «retour» apparaît, utilisez les touches haut / bas pour vous déplacer entre les lignes.

Une fois la saisie terminée, sélectionnez l'icône «Enregistrer» sur le clavier à l'écran et appuyez sur Entrée.



Mode compteur de sessions :

- Lorsque le mode compteur est sélectionné, le nombre total de tests effectués par le testeur sera affiché dans chaque catégorie. Le compteur total ne peut pas être remis à zéro cependant le compteur de sessions peut être réinitialisé.



Session/
Compteur
Total



Session
Total

Utilisez les touches directionnelles afin de sélectionner le mode compteur puis appuyez sur Entrer [↵].

Utilisez les touches directionnelles pour sélectionner l'icône de la batterie et appuyez sur Entrer [↵].

Utilisez les touches ▲ ou ▼ pour sélectionner le type de véhicule puis appuyez sur Entrer [↵] pour remettre le compteur à zéro.

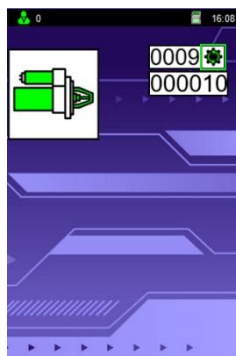

Utilisez les touches directionnelles pour sélectionner l'icône du démarreur et appuyez sur Entrer [↵].

Appuyez sur Entrer [↵] pour remettre le compteur à zéro.

Utilisez les touches directionnelles pour sélectionner l'icône de l'alternateur et appuyez sur Entrer [↵].

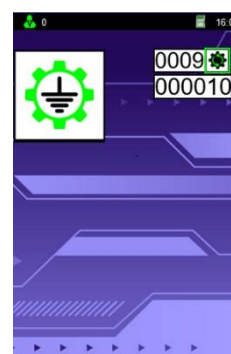
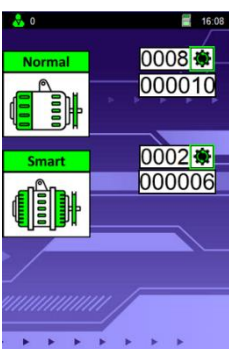

Utilisez les touches ▲ ou ▼ pour sélectionner le type d'alternateur puis appuyez sur Entrer [↵] pour remettre le compteur à zéro.

Utilisez les touches directionnelles pour sélectionner l'icône de la masse et appuyez sur Entrer [↵].

Appuyez sur Entrer [↵] pour remettre le compteur à zéro.



Libretto di istruzioni

Il nuovo tester batteria T13 con Advance Technology 12V / 24V, è progettato per eseguire quattro tipi di test :

Test batteria:	Analizza lo stato della batteria, tramite un sistema di controllo a microprocessore (solo per batterie a 12V).
Test masse:	Analizza lo stato del circuito, misurando la sua resistenza (solo per il circuito a 12V).
Test di avviamento:	Verifica l'efficienza della batteria durante la messa in moto (sia 12V che 24V).
Test dell'alternatore:	Verifica lo stato dell'alternatore, controllo del voltaggio di carica massimo e minimo in uscita (sia 12V che 24V).

PROCEDURE OPERATIVE:

11. Collegare le pinze del Tester ai terminali della batteria per attivare il dispositivo. Il valore di tensione dell'accumulatore sarà visualizzato sullo schermo del T13.
12. Premere un qualsiasi tasto per accedere al menu principale ed effettuare una delle seguenti operazioni :

e. Ingresso dati	f. Test	g. Memoria del Tester	h. Configurazione
------------------	---------	-----------------------	-------------------

13. Per inserire i dati d'intestazione, relativi all'operatore, andare in configurazione e scegliete la voce dati.
 - a. Una volta entrati nella voce dati, si possono inserire, tramite la tastiera virtuale, il nome, l'indirizzo e il numero di telefono relativi all'officina. Per registrarli in maniera permanente, premere sul simbolo del disco che si trova sul lato in alto a destra della tastiera virtuale. Queste informazioni appariranno sulla stampa di ogni singolo test effettuato.
14. Per inserire il numero di targa o il numero di telaio, selezionare il simbolo della tastiera dal menu principale e cliccare sul simbolo del disco che si trova sulla tastiera virtuale. Uno scanner per i codici a barre (venduto separatamente) può essere connesso per memorizzare i codici a barre e stamparli direttamente sullo scontrino del test.
15. Per modificare data e ora, selezionare la modalità Configurazione e scegliere data e ora.
16. Per attivare/disattivare il suono, selezionare la modalità Configurazione e selezionare suono.
17. Per effettuare i test, selezionare il simbolo dello stetoscopio.
 - a. È possibile scegliere il tipo di veicolo su cui procedere: auto, camion o moto. Nota bene: per le batterie collegate 24V, devono essere testate una per volta a 12V.
 - b. Per eseguire il test batteria, selezionare la modalità batteria, successivamente il tipo di batteria appropriato e inserire le specifiche del costruttore (CCA, EN1 etc.).
 - c. Per effettuare il test dell'alternatore, seguire le istruzioni che appaiono sul display del dispositivo.
 - d. Per effettuare il test di messa in moto, seguire le istruzioni che appaiono sul display del dispositivo.
 - e. Per effettuare il test delle masse, seguire le istruzioni che appaiono sul display del dispositivo.
 - f. Una volta terminati i test, i risultati appariranno sullo schermo e potranno essere stampati premendo il tasto di stampa del tester.
18. Per rivedere i risultati precedentemente registrati, selezionare il simbolo della <<lente di ingrandimento>> dal menu principale
 - a. Scorrere i risultati e selezionare quello ricercato, se necessario stampare.
19. Per eliminare i risultati dei test registrati, selezionare il simbolo <<cestino>> dal menù dei parametri.
 - a. Scorrete i risultati dei test ed eliminateli se necessario.
20. L'alloggio della carta SD si trova sull'lato destro del tester. Assicuratevi di inserire la carta SD nel verso giusto, senza forzare. Per rimuoverla, utilizzare una piccola punta per esercitare pressione sulla carta.



Accensione del dispositivo

Per attivare il Tester T13, le pinze devono essere collegate ai terminali della batteria da verificare. La pinza rossa sul terminale della batteria positivo (+) e la pinza nera sul terminale della batteria negativa (-). Sul display sarà visualizzato il voltaggio della batteria, successivamente sarà possibile, premendo un qualsiasi tasto, accedere al menu principale.



Messaggio iniziale di benvenuto



Menu principale

Procedura test Batteria :

La batteria montata su un veicolo può presentare della carica residua. Per eseguire correttamente il test, questo tipo di carica va eliminata. Pertanto si consiglia di lasciare i fari del veicolo accesi per 30 secondi a motore spento. Successivamente, lasciare la batteria a riposo, con quadro spento, per 60 secondi prima di effettuare il test.

Osservazioni : La corrente di spunto massima per il test batteria in modalità MOTO è di 600A
La corrente di spunto massima per il test batteria in modalità AUTO è di 2000A.
In modalità MOTO è disponibile solo il test batteria. In modalità auto sono disponibili tutti i test.



Utilizzare i tasti di direzione per selezionare il tasto < Test > e premere invio

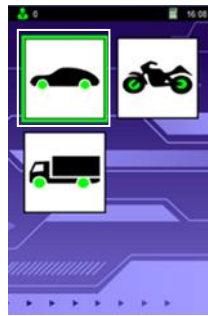

Utilizzate i tasti di direzione per selezionare il tipo di veicolo



Utilizzate i tasti di direzione per selezionare il test che si vuole effettuare

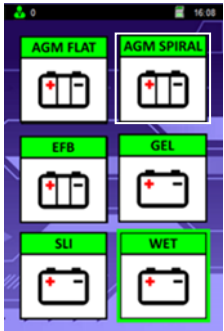

Selezionare il tipo di batterie



Selezionare i dati presenti sull'etichetta della batteria da testare



Utilizzate le frecce per inserire il valore da +/- 5 a +/- 100

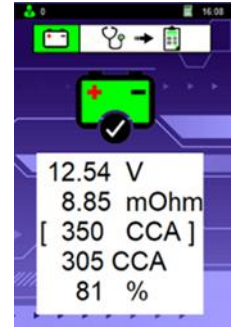

Premere il pulsante di stampa per stampare i risultati.

Valutazione dei risultati del test batteria:



Lampeggiante

La batteria è in buono stato



Lampeggiante

La batteria è OK ma deve essere ricaricata. (Lo stato di carica è debole)



Lampeggiante

La batteria deve essere sostituita



Lampeggiante

La batteria deve essere ricaricata e testata di nuovo per accertare il suo stato.

Risultati dei test: (Esempio dei valori)

Volts :	12,68V	Indica lo stato di carica [SOC] della batteria testata.
Stato della batteria :	320 CCA	Indica la capacità nominale della batteria.
Potenza disponibile :	286 CCA	Indica la potenza reale d'uscita misurata della batteria.
Resistenza interna :	9,45 mOhm	Indica la resistenza interna misurata della batteria.
Vita :	89 %	Indica il livello di vita della batteria (Salute) in percentuale.

Se tale valore è meno di 50%, il tester indicherà che la batteria deve essere sostituita.

Osservazioni sulla resistenza interna: l'intervallo normale per una batteria buona è tra 2-4 mOhm e 10-15 mOhm. Al di sotto di questo valore, una batteria è considerata troppo vecchia o solfatata. Le batterie per le moto possono avere una resistenza interna più elevata e essere considerate buone grazie al loro elevato valore di CCA. Si raccomanda sempre di fare riferimento al valore fornito dal produttore della batteria.

Osservazioni: rilevato carica residua

Se il tester rileva una carica residua, dovete eseguire la seguente procedura. Una volta eseguita, procedere col test.

Girare la chiave nel quadro in posizione ON

Fari accesi

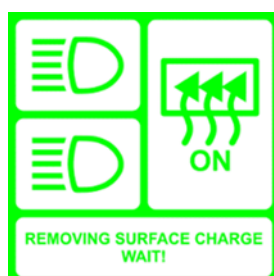

Girare la chiave nel quadro in posizione OFF

Fari spenti

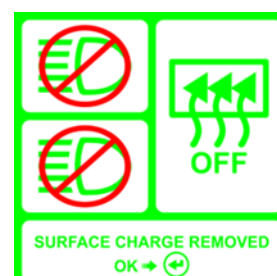



Osservazioni: rilevato cattivo contatto delle pinze sui terminali della batteria

Se le Pinze non sono ben collegate, il test non può essere preciso. Staccare il tester dalla batteria, pulire i terminali e ripetere l'operazione per eseguire il test.



Lampeggiante Intermittente

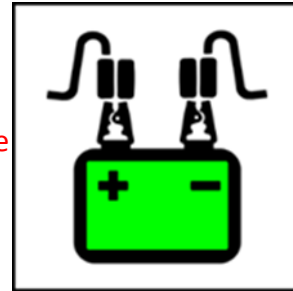

Osservazioni: rilevato stato di carica debole (< 75%) – selezione della temperatura

Se il tester rileva che la batteria è scarica, chiederà di inserir la temperatura ambiente.

(-)Meno di 0°C

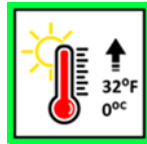
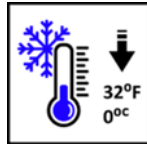

Più di 0°C

Osservazioni: rilevato stato di carica debole (< 75%) – Selezione dello stato di carica

Se il tester rileva che la batteria è scarica, chiederà di selezionare lo stato di carica



Dopo la carica

Prima della carica





Procedura test Avviamento:

Una volta collegate le pinze, seguire le istruzioni sul display per effettuare il test di avviamento.

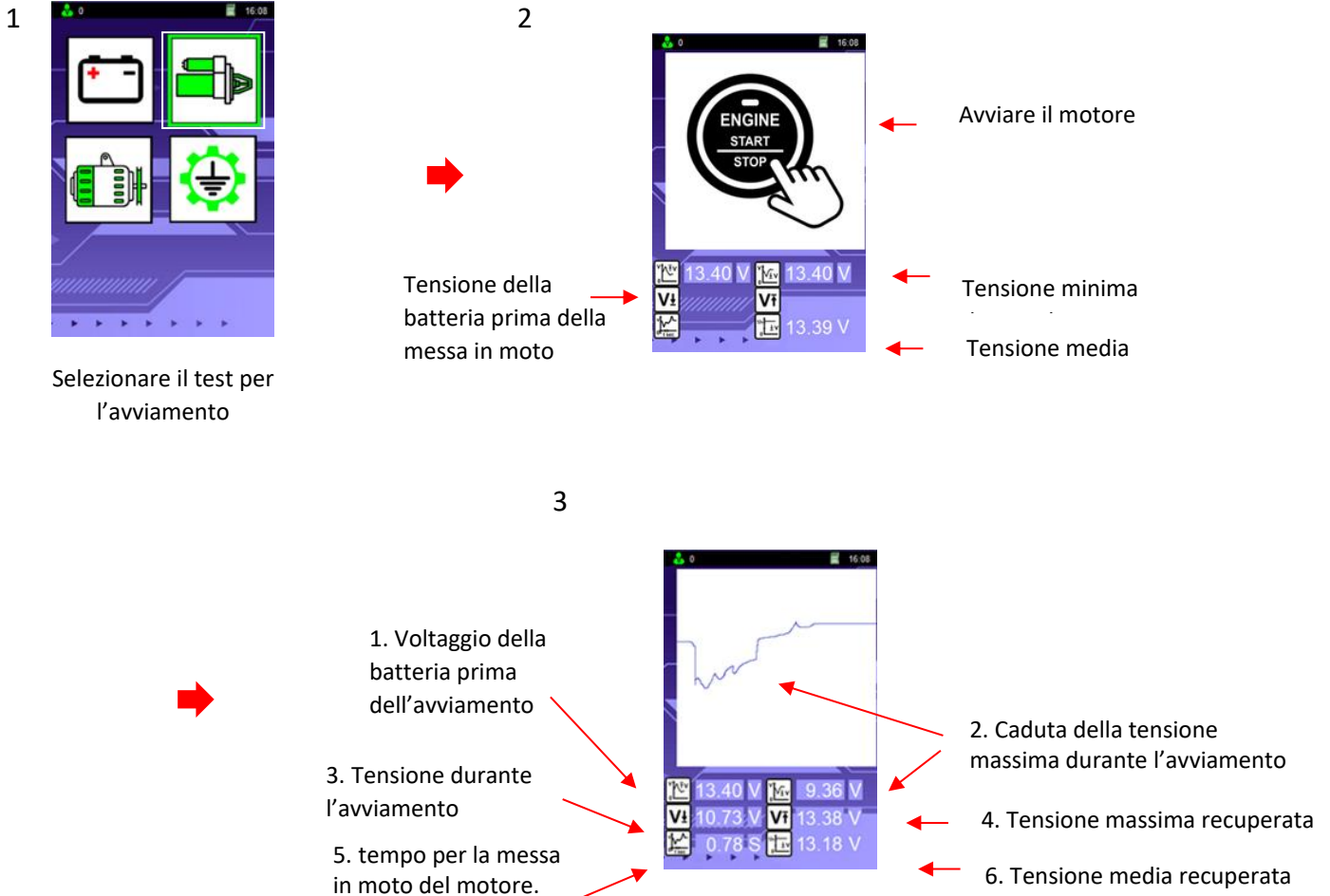

Valutazione dei risultati dei test di Avviamento:

7. Tensione della batteria prima della messa in moto: **13.40 V**.
Indica lo stato di carica (SOC) della batteria prima dell'avviamento del motore.
8. Caduta massima della tensione durante la messa in moto: **9.36 V**.
Indica la caduta di tensione registrata quando il motorino avvia il motore, causata dal carico, durante l'avviamento.
9. Tensione durante la messa in moto: **10.73 V**.
Indica la tensione d'avviamento reale. Se tale tensione scende sotto il valore di 9,6V, per i circuiti a 12V, o sotto a 19,2V, per i circuiti a 24V, significa che la batteria è debole o a fine vita.
10. Tensione massima recuperata: **13.38 V**.
Indica la tensione massima della batteria prima che l'alternatore inizi la sua azione di carica a motore avviato.
11. Tempo necessario al motorino d'avviamento per la messa in moto del motore: **0.78S**.
Indica il periodo (in secondi) necessari per la messa in moto del motore, è determinata dallo stato della batteria. Più il tempo di messa in moto è breve, migliore è lo stato della batteria. Le batterie deboli necessitano di un maggior tempo per l'avviamento del motore.
12. Tensione media recuperata: **13.18 V**.
È la tensione rilevata sulla batteria dopo la messa in moto, durante la fase di recupero, prima della ricarica da parte dell'alternatore. indica lo stato della batteria rispetto alla tensione di stato di carica (SOC).



Procedura test Alternatore:

Questo test deve essere eseguito solo a motore avviato, con il cambio in posizione NEUTRA o in modalità « P » e con il freno a mano inserito.

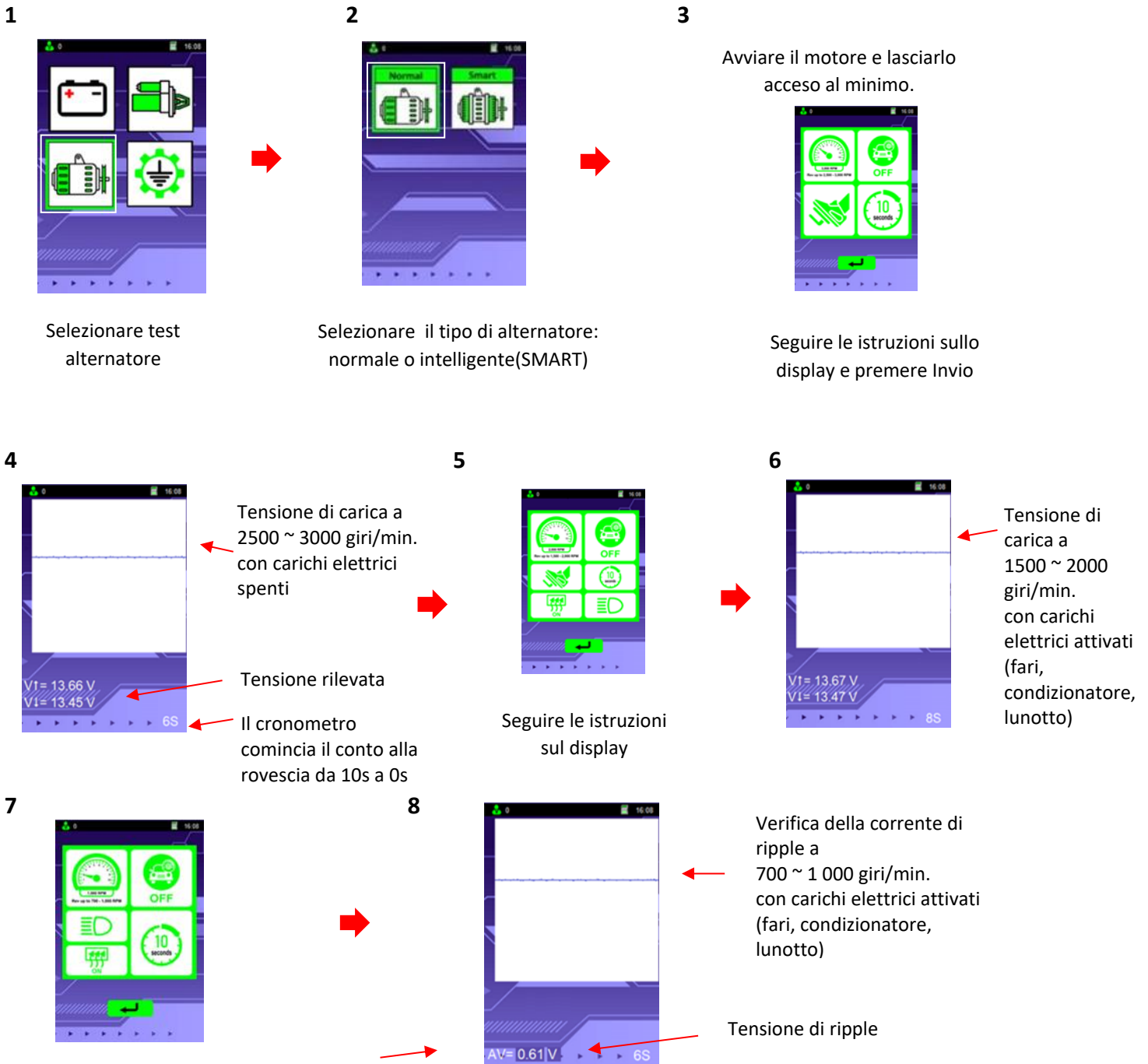

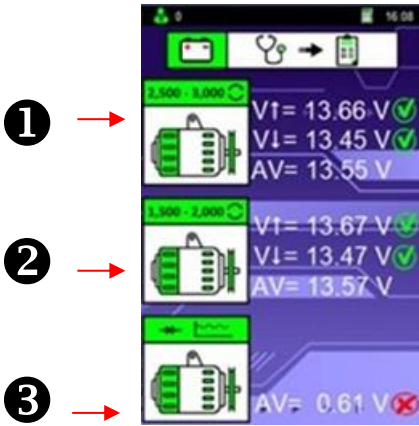

Simboli

V↑: Voltaggio Massimo (V max)

V↓: Voltaggio Minimo (V min)

AV: Voltaggio Medio

OR

I dati ottenuti possono essere confrontati, come da tabella seguente, al fine di verificare lo stato dell'alternatore. I risultati sono classificati in tre categorie:

4. Test senza carichi elettrici (2 500 ~ 3 000 giri/min.)

2.5K ~ 3.0K RPM Without Load	12V Alternator Volt Limits		24V Alternator Volt Limits	
	Normal	Smart	Normal	Smart
V↑	< 15.0V	< 16.2V	< 30.0 V	< 32.4V
V↓	> 13.3V	> 12.4V	> 26.6 V	> 24.8 V

5. Test con carichi elettrici (1 500 ~ 2 000 giri/min. - fari, condizionatore e lunotto attivi)

1.5K ~ 2.0K RPM With Load	12V Alternator Volt Limits		24V Alternator Volt Limits	
	Normal	Smart	Normal	Smart
V↑	> 13.8V	> 12.4V	> 27.6 V	> 24.8V
V↓	> 12.6V	> 12.0V	> 25.2 V	> 24.0 V

6. Test della corrente di ripple con carichi elettrici (motore al minimo: 700 ~ 1 000 giri/min.)

La corrente di ripple dell'alternatore viene verificata per vedere se rientra in una media del limite di 0,5 V. Se uno dei diodi è difettoso, produrrà un valore superiore a 0,5 V. Questo indica che l'alternatore non funziona correttamente.

Per la stampa dei risultati, premere il simbolo della stampante sul tester. Premere il tasto invio per uscire dal menu del tester.



Procedura test Massa (Ground Test):

A motore spento, collegare le pinze ai terminali della batteria.



Utilizzare le frecce direzionali per selezionare il test Masse



Questa schermata indica che la pinza negativa deve essere fissata al telaio del veicolo .



Test in corso

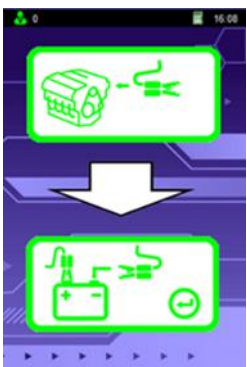

Questa schermata indica che la pinza negativa deve essere fissata sul terminale negativo della batteria.



Test in corso



I risultati del test indicano che la connessione a terra è buona.

Lampeggiante

Resistenza



I risultati del test indicano che la connessione di massa a terra non è buona.

Lampeggiante

Resistenza rilevata



Risultato del test non valido. Ripetere il test.

Lampeggiante

Nessuna resistenza
Resistenza non rilevata



Inserimento dei dati d'intestazione da stampare sullo scontrino:

Per inserire le informazioni relative al cliente, prima di effettuare il test, accedere dal menu principale alla sezione "inserimento dati".



Grazie allo scanner (venduto separatamente) è possibile inserire il codice a barre della batteria e riportarlo direttamente sullo scontrino di stampa.

Utilizzare le frecce direzionali per selezionare i dati relativi ai clienti, targa o telaio della vettura. Queste informazioni verranno registrate nella memoria del tester e pronte per essere stampate.

Il simbolo del disco, a destra della tastiera, serve per registrare i dati.

Utilizzare le frecce direzionali per selezionare l'icona relativa all'inserimento dati e premere invio



Procedere con i test elencati : batteria,avviamento, alternatore, masse ; come spiegato precedentemente

Inserimento dati relativi all'operatore/officina:

per inserire i dati societari relativi all'officina, accedere al menu delle impostazioni e selezionare il modo desiderato.

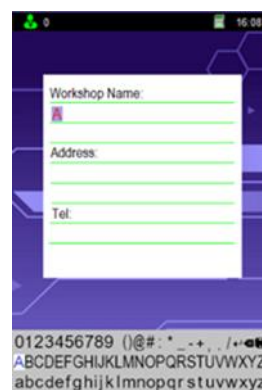
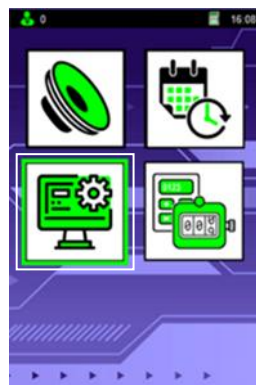

Utilizzare le frecce direzionali per selezionare <configurazione> e premere Invio

Utilizzare le frecce direzionali per selezionare <tastiera> e premere Invio

Inserire i dati e premere sul disco a destra della tastiera per registrare i dati.



Quando voi si spostate tra le linee, selezionate il tasto «ritorno» sulla tastiera dello schermo. Una volta che il tasto «ritorno» appare, utilizzate i tasti alto/ basso per spostarvi entro le linee.
Una volta eseguita la vostra scelta, selezionate il tasto «Registra» sulla tastiera dello schermo e premete su Entra.



Modalità Contatore test :

- Quando la modalità contatore test è selezionata, il numero totale di test si affischerà dentro tutte le categorie. Il contatore totale non potrà mai essere messo a zero mentre il contatore di sezione può essere resettato.



Sessione/
Contatore
Totale

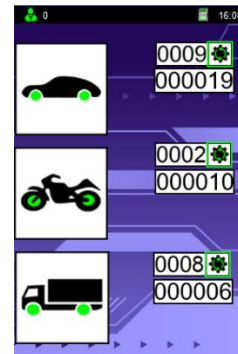

Sessione
Totale

Utilizzate i tasti direzionali per selezionare la modalità contatore e poi premete il tasto [↵].

Utilizzate i tasti direzionali per selezionare l'icona della batteria e poi premete il tasto [↵].

Utilizzate i tasti ▲ ou ▼ per selezionare il tipo di veicolo e poi premete il tasto Entrer per rimettere il contatore a zero.

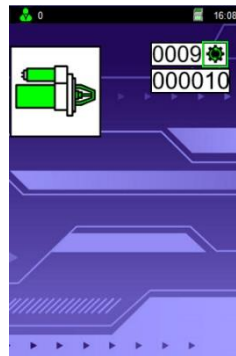

Utilizzate i tasti direzionali per selezionare l'icona del motorino di avviamento e poi premete il tasto [↵].

Premete su [↵] per rimettere il contatore a zero

Utilizzate i tasti direzionali per selezionare l'icona dell'alternatore e poi premete su [↵].

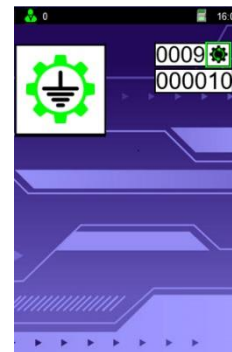
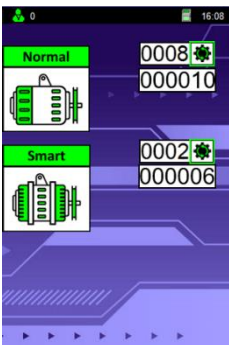

Utilizzate i tasti ▲ ou ▼ per selezionare il tipo di alternatore e dopo premete sul tasto [↵] per rimettere a zero il contatore

Utilizzate i tasti direzionali per selezionare l'icona della massa e poi premete sul tasto [↵].

Premete su [↵] per rimettere il contatore a zero



Manual del Usuario

El tester de batería avanzado T13 funciona en sistemas de 12V / 24V y es capaz de realizar cuatro tipos de pruebas:

Prueba de batería: Analiza el estado de la batería utilizando un método de prueba controlado por un microprocesador (baterías de 12V).

Prueba de tierra: Analiza el estado del circuito de retorno eléctrico (solo en sistema de 12V).

Prueba de arranque: Comprueba la eficacia del arranque de la batería para predecir cuándo la batería fallará en el arranque de un vehículo (sistema 12V/24V).

Prueba de alternador: Esta prueba comprueba el estado del alternador probándolo sobre diferentes cargas y realizando una prueba de diodo de ondulación (sistema 12V/24V).

Procedimiento operativo:

1. Conecte las pinzas T13 a los terminales de la batería para encenderla. El voltaje de la batería aparecerá en la pantalla.
2. Pulse cualquiera tecla para avanzar a la pantalla de inicio. Una vez en la pantalla de inicio varios modos están disponibles:

a. Detail Entry	b. Test	c. Memory storage	d. Settings
-----------------	---------	-------------------	-------------

3. Para introducir la información del taller, seleccione el modo de configuración y seleccione la entrada de datos.
 - a. Una vez en este modo se puede introducir el nombre del taller, la dirección y el número de teléfono usando el teclado en pantalla. Para guardar los resultados, pulse el símbolo de disco en la esquina superior derecha del teclado virtual. Esta información aparecerá en los resultados de la prueba cuando se imprima.
4. Para introducir la placa de matrícula, VIN o número de cliente, seleccione el símbolo de "Detail Entry" en el menú principal, también haga clic en el símbolo de disco en el teclado virtual. Un escáner de código de barras (se vende por separado) se puede conectar para escanear códigos de barras e imprimir el número de código de barras en el recibo directamente.
5. Para cambiar la fecha y hora, seleccione el modo "Settings" y elija "Date & Time"
6. Para activar/desactivar el sonido, seleccione el modo "Settings" y elija "Sound"



7. Para realizar una prueba, seleccione el símbolo de 'Estetoscopio':
 - a. Se pueden seleccionar los modos de coche, motocicleta o camión. Nota para las baterías de 24V: deben estar separadas y ser probadas individualmente en 12V únicamente.
 - b. Para la prueba de batería, seleccione el modo de batería y elija el tipo de batería adecuado e introduzca las especificaciones de la batería (CCA, EN1, etc.).
 - c. Para una prueba de alternador, siga las instrucciones mostradas en el tester.
 - d. Para una prueba de arranque, siga las instrucciones mostradas en el tester.
 - e. Para una prueba de tierra, siga las instrucciones mostradas en el tester.
 - f. Una vez las pruebas completadas, los resultados se mostrarán y podrán imprimirse pulsando el botón de impresión del tester.
8. Para ver los resultados almacenados, seleccione el símbolo 'Lupa' en el menú principal
 - a. Navegar por los resultados para ver cada prueba y, si es necesario, imprimir los resultados.
9. Para eliminar los datos de prueba almacenados, simplemente seleccione el símbolo 'Papelera' en el menú de configuración.
 - a. Navegar por las pruebas y borrar cada prueba según sea necesario.
10. La tarjeta SD se puede insertar o quitar en el lado derecho del tester. Por favor, asegúrese de insertarla al revés como se indica en el tester. Nunca fuerce la tarjeta en la ranura. Para sacarla, use un clip para presionarla.

Encendido en el dispositivo

Para encender el T13, las pinzas deben estar conectadas a los terminales de la batería. Encienda el T13 conectando la pinza roja al terminal positivo (+) y la pinza negra al terminal negativo (-). El T13 mostrará el voltaje de la batería y luego se dirigirá a la pantalla de inicio una vez presionada la tecla.



Pantalla de bienvenida



Pantalla principal



Realizar una prueba de batería

Cuando un vehículo ha estado funcionando, la batería llevará una carga de superficie. Con el fin de probar correctamente la batería, la carga de superficie debe eliminarse encendiendo los faros durante 30 segundos con el motor apagado. Dejar la batería en reposo con el encendido apagado durante al menos 60 segundos antes de probar la batería.

Nota: La corriente máxima de arranque de una batería probada en modo motocicleta es de 600A

La corriente máxima de arranque de una batería probada en el modo de coche es 2000A

En modo motocicleta, sólo está disponible la prueba de batería. En modo coche, todas las pruebas están disponibles.



Utilice las teclas direccionales para seleccionar <Test> y pulse 'enter'

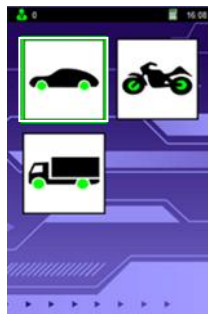

Utilice las teclas direccionales para seleccionar el vehículo



Utilice las teclas direccionales para seleccionar la prueba requerida



Seleccione el tipo de batería adecuado



Seleccione la medida de prueba según su batería



Utilice las flechas para cambiar el valor en +/- 5 y por +/- 100

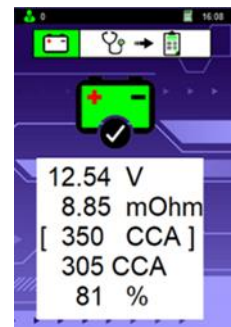

Pulse el botón de impresión en el comtester para imprimir los resultados.



Interpretación de los resultados de la prueba de batería:



← Parpadea

La batería está en buenas condiciones



← Parpadea

La batería está bien, pero necesita ser recargada (Estado de carga es baja).



← Parpadea

Hay un problema en la batería y debe ser reemplazada.



← Parpadea

La batería necesita ser recargada y probada de nuevo para confirmar los resultados finales.

Resultados de la prueba: (valores de ejemplo)

Voltios:	12.68V	Indica el estado de carga [SOC] de la batería probada.
Rango de batería:	320 CCA	Indica la potencia nominal de la batería
Potencia disponible:	286 CCA	Indica la potencia real de salida.
Resistencia interna:	9.45 mOhm	Indica la resistencia interna de la batería probada.
LIFE:	89	Indica la esperanza de vida de la batería en porcentaje.

Si cae por debajo del 50 %, el tester indicará que la batería debe ser reemplazada.

Nota para la resistencia interna: En promedio el rango normal es de 2-4 mOhm a 10-15 mOhm para ser considerado bueno. Por encima de estos valores, una batería se considera envejecida o sulfatada. Las baterías de motocicletas pueden tener una mayor resistencia interna y seguir considerándose buenas debido a sus valores de CCA más bajos. Por favor, consulte siempre los valores dados por el fabricante de la batería.

Nota: Carga superficial detectada.

Si el tester detecta una carga superficial, debe seguirse el siguiente procedimiento. Una vez completado, proceder con la prueba.

Gire la llave de encendido a la posición ON

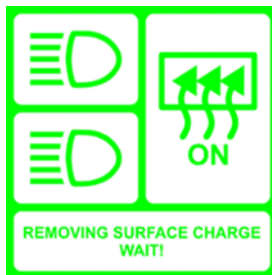

Luces de cruce y posición encendidas.

Gire la llave de encendido a la posición ON



Luces de cruce y posición apagadas.

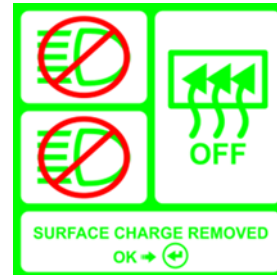



Nota: Conexiones terminales débiles detectadas

Cuando la conexión a la batería no es suficientemente segura para realizar una prueba con precisión. El tester mostrará el siguiente icono en la pantalla. Desconectar el tester de la batería, eliminar la suciedad de los terminales y volver a conectarlos con firmeza. Repetir el procedimiento de prueba.



Parpadeando
alternativamente

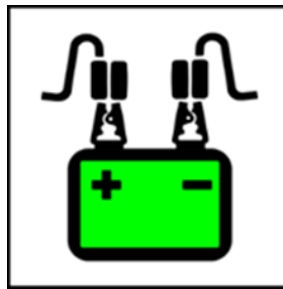

Nota: Bajo estado de carga (>75%), selección de temperatura

Si el tester detecta que la batería está descargada se le pedirá la opción de selección de temperatura

(-) 0°C y menos

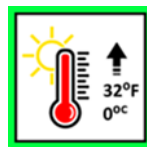
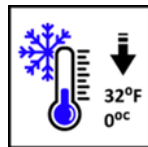

(+) 0°C y mas

Nota: Bajo estado de carga (>75%), selección de estado de carga

Si el tester detecta que la batería está descargada se le pedirá la opción de selección de estado de carga.

Antes de la selección de carga

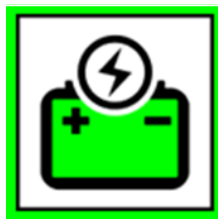

Después de la selección de carga





Realizar una prueba rápida: Arranque

Una vez las pinzas conectadas, siga las instrucciones en pantalla para realizar una prueba de arranque.

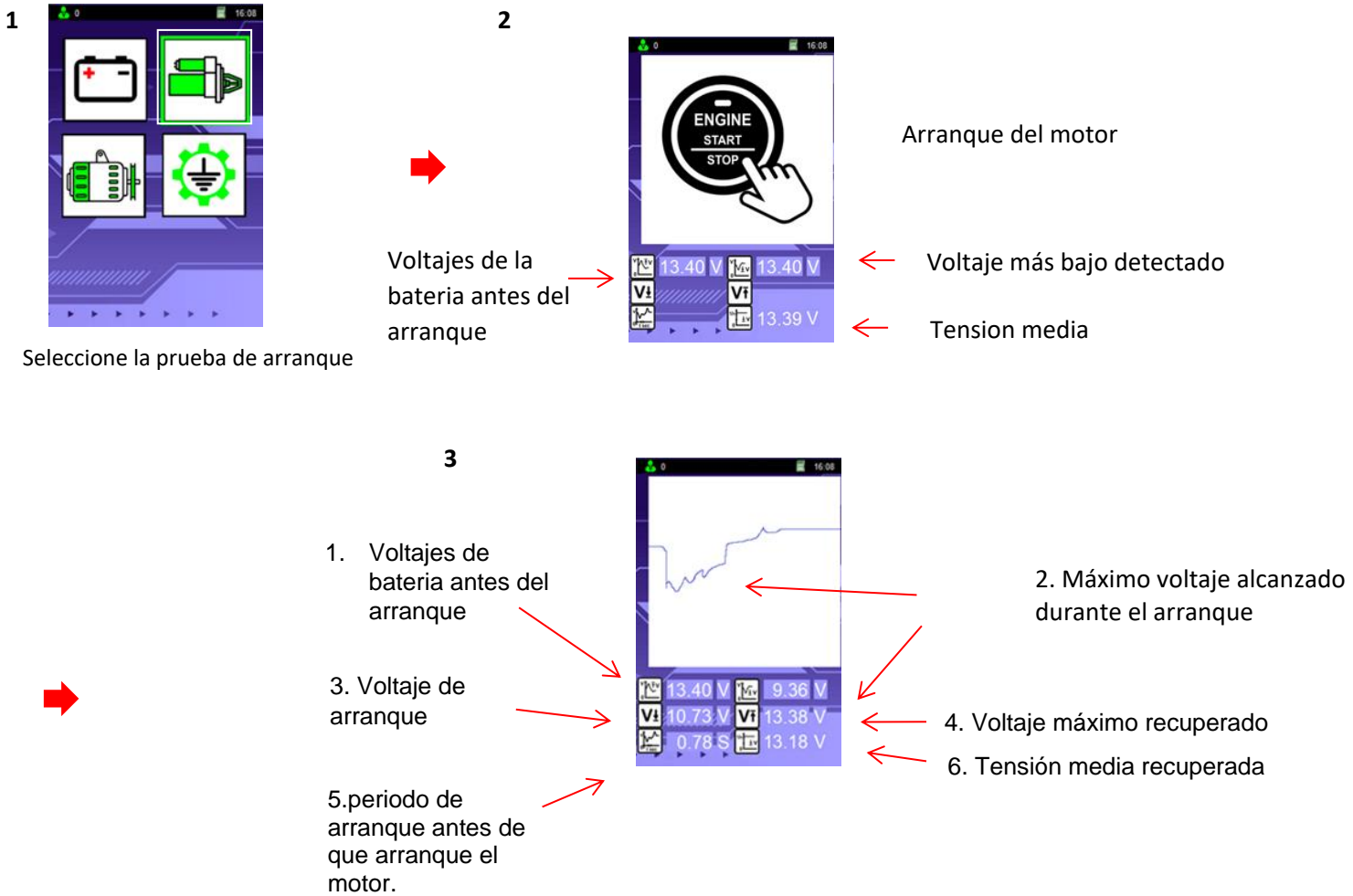

Interpretación de los resultados de la prueba de arranque:

1. Tensión de la batería antes del arranque: **13.40 V**
Indica el estado de carga (SOC) de la batería antes de arrancar el motor.
2. Caída máxima de tensión durante el arranque: **9.36 V**
Indica la caída de voltaje obtenido cuando el motor arranca a causa de la carga durante el arranque.
3. Tensión de arranque: **10.73 V**
Indica el voltaje de arranque actual. Si el voltaje cae por debajo de 9,6V para el sistema de 12V o por debajo de 19,2V para el sistema de 24V eso significa que la batería está agotada y está llegando al final de su vida operativa.
4. Máximo voltaje recuperado: **13.38 V**
Indica el voltaje de subida más alto antes de entrar en la carga mientras el motor está en marcha.
5. Período de arranque antes de que se inicie el encendido del motor: **0.78S**
Indica el período (en segundos) durante el arranque antes de que el motor se ponga en marcha y determina el estado de la batería. Cuanto menor sea el tiempo de arranque, mejor será el estado de la batería. Las baterías agotadas tardarán más en arrancar el motor.
6. Tensión media recuperada: **13.18 V**
Este voltaje fue obtenido durante la etapa de recuperación después del encendido, antes de pasar el voltaje de carga. Indica lo bien que está la batería en su recuperación de voltaje comparado con el voltaje en estado de carga (SOC).



Realizando una prueba de alternador:

Esta prueba sólo se debe realizar con el motor del vehículo apagado, su transmisión en NEUTRO o PARKING y con el freno de mano echado.

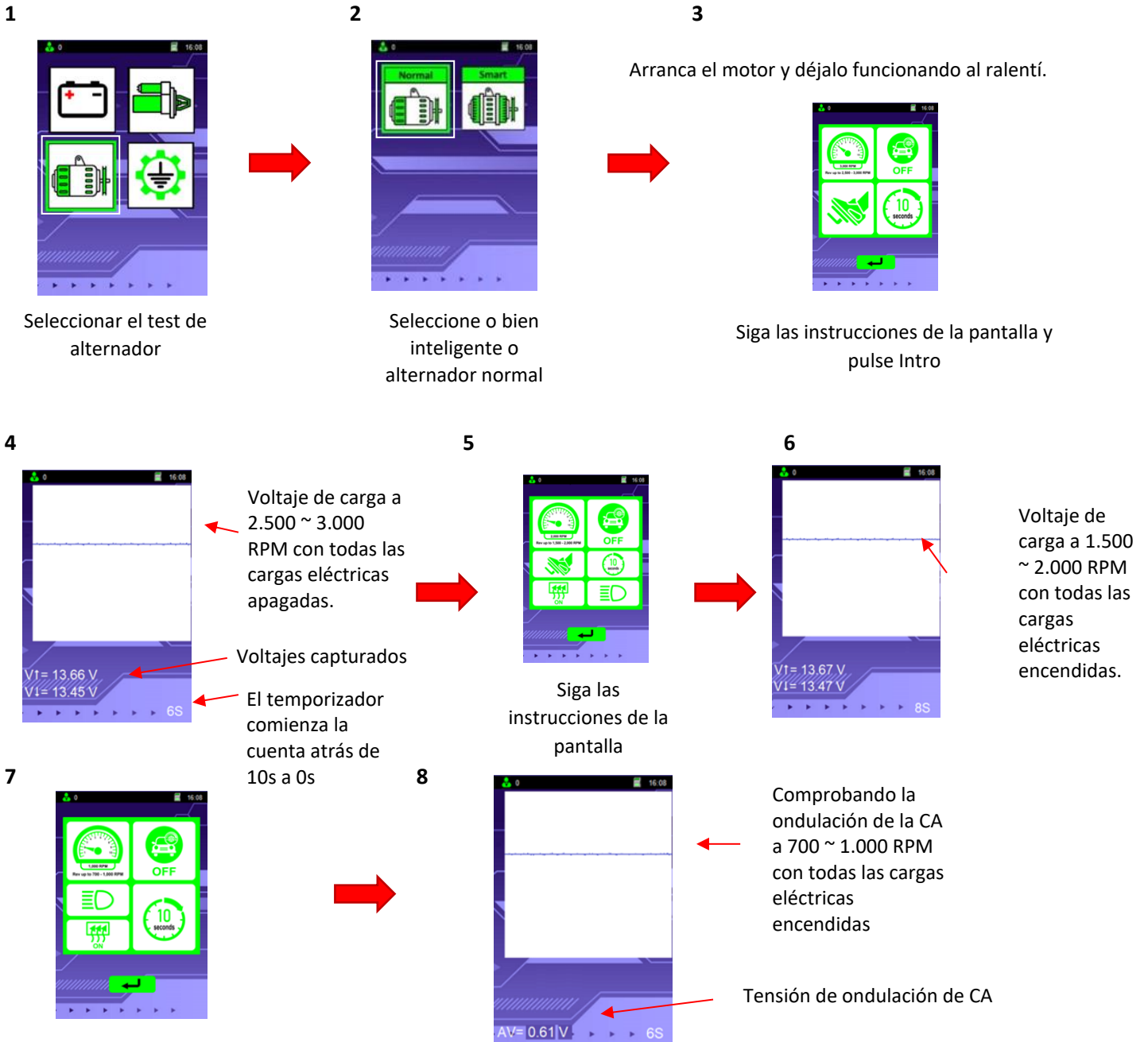

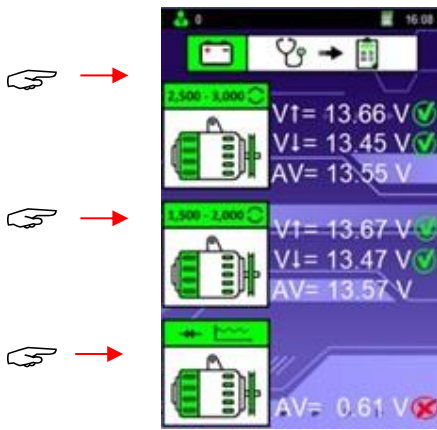

Symbols

V ↑: Voltaje Máximo (V max)

V ↓: Voltaje Mínimo (V min)

AV: Voltaje Medio

Los resultados registrados pueden compararse con las tablas que figuran a continuación para indicar el estado del alternador, y se clasifican en tres secciones:

1. Sin la prueba de carga eléctrica (2.500 ~ 3.000 RPM).

2.5K ~ 3.0K RPM Sin carga	12V Limite de voltaje del alternador		24V Limite de voltaje del alternador	
	Normal	Smart	Normal	Smart
V↑	<15.0V	<16.2V	<30.0V	<32.4V
V↓	>13.3V	>12.4V	>26.6V	>24.8V

2. Con la prueba de carga eléctrica

(1.500 ~ 2.000 RPM).

2.5K ~ 2.0K RPM Sin carga	12V Limite de voltaje del alternador		24V Limite de voltaje del alternador	
	Normal	Smart	Normal	Smart
V↑	>13.8V	>12.4V	>27.6V	>24.8V
V↓	>12.6V	>12.0V	>25.2V	>24.0V

3. Prueba de ondulación del diodo AC con carga (Velocidad de ralentí: 700 ~ 1.000 RPM)

Se comprueba la ondulación de la CA del alternador para ver si está dentro de un promedio del límite de 0,5V. Si uno de los diodos está defectuoso, la onda AC producirá más de los 0,5V aceptados. Indicando que el alternador no está funcionando correctamente.

Para imprimir los resultados, pulse el símbolo de la impresora en el tester. Al pulsar la tecla de retorno se saldrá de las pruebas.



Realizando una prueba de tierra:

Con el motor apagado, conecte las pinzas a los terminales de la batería.



Use las teclas direccionales para seleccionar la prueba de tierra



Esta pantalla indica que la pinza negativa debe ser fijada al chasis o al motor.



Pruebas en curso

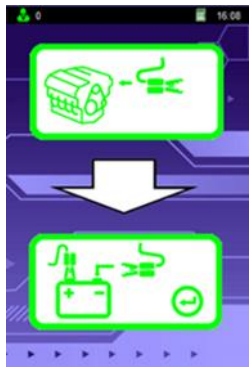

Esta pantalla indica que la pinza negativa debe ser conectada de nuevo al terminal negativo de la batería



Pruebas en curso



El resultado de la prueba indica que la conexión a tierra es buena.

Parpadeo

Lectura de la resistencia



El resultado de la prueba indica que la conexión a tierra no es buena.

Parpadeo

Lectura de la resistencia



El resultado de la prueba no es concluyente, repita la prueba.

Parpadeo

No hay lectura de Resistencia
No se detecta resistencia



Entrada de detalles:

Para ingresar información particular del cliente antes de realizar una prueba, acceda al modo de ingreso de detalles en el menú principal.

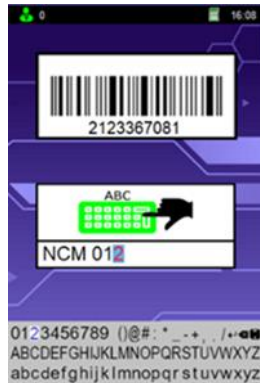

Utilizando el escáner de código de barras opcional, escanee el código de las baterías y los detalles aparecerán en el campo de código de barras.

Utilice las teclas de dirección para introducir la información de los clientes como el nombre, la matrícula o el número de identificación del vehículo. Esta información encabezará los resultados de la prueba en la memoria del dispositivo y también aparecerá en los resultados de la prueba una vez

Use las teclas direccionales para seleccionar Entrada de detalles y pulse Intro

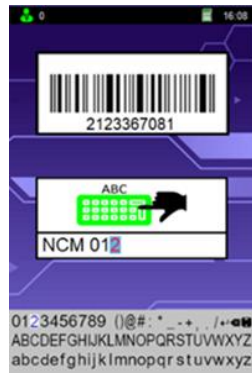

Proceda con las pruebas requeridas como se explica en las secciones anteriores, Prueba de la Batería, Prueba de Arranque, Prueba del Alternador, Prueba de Tierra.

Entrada de información del taller:

Para introducir el nombre, la dirección y la información de contacto del taller, acceda al menú de ajustes y seleccione el modo de entrada de datos.

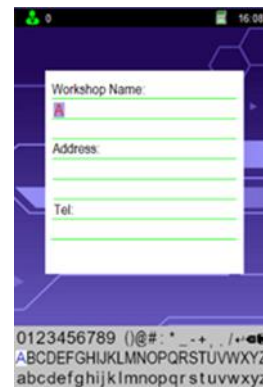
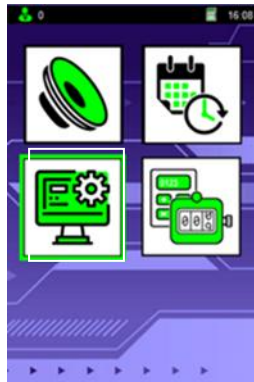

Use las teclas direccionales para seleccionar <Setup> y pulse intro

Use las teclas direccionales para seleccionar <Fecha y Hora> y pulse intro

Use the directional keys to input the required data.



Cuando se mueva entre líneas, seleccione la tecla 'return' del teclado en pantalla. Una vez que aparezca el icono de 'retorno', use las teclas arriba/abajo para moverse entre líneas. Una vez que la entrada se haya completado, seleccione el icono 'Save' en el teclado en pantalla y presione enter.

Modo de contador de sesiones:

1. Cuando se selecciona el modo Contador, el número total de pruebas realizadas por el probador se mostrará en cada categoría. El contador total no se puede restablecer a cero, sin embargo, el contador de sesiones se puede restablecer.



Sesion/
Contador
Total



Sesion
Total

Utilice las teclas de dirección para seleccionar el modo Contador y luego presione Entrar [↵].

Utilice las teclas de dirección para seleccionar el icono de la batería y luego presione Entrar [↵].

Use las teclas ▲ o ▼ para seleccionar el tipo de vehículo y luego presione Enter [↵] para restablecer el Contador a

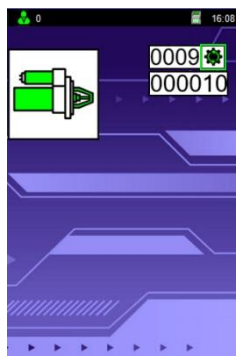
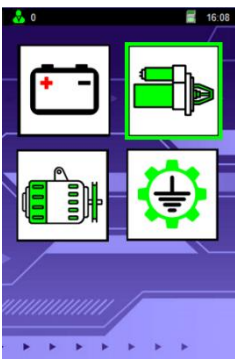

Utilice las teclas de dirección para seleccionar el icono de inicio y luego presione Entrar [↵].

Presione Enter [↵] para restablecer el contador a cero.

Utilice las teclas de dirección para seleccionar el icono del alternador y luego presione Entrar [↵]

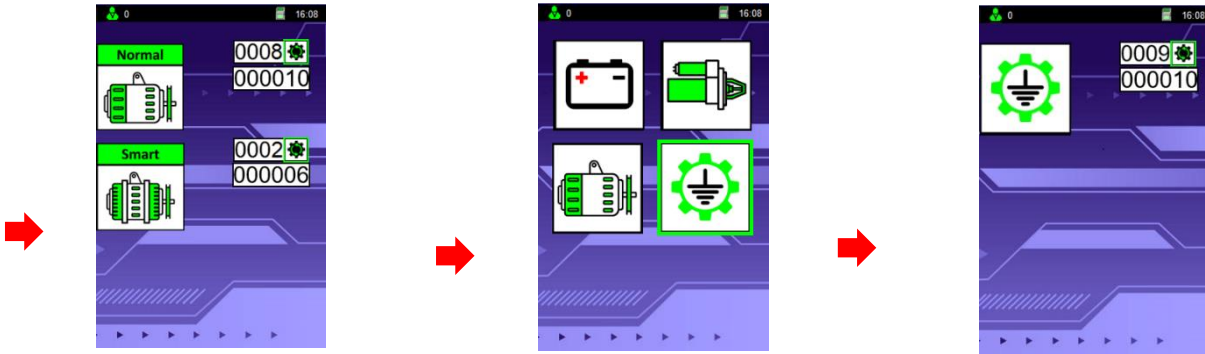

Use las teclas de dirección ▲ o ▼ para seleccionar el tipo de alternador y luego presione Enter [↵] para restablecer el contador a cero.

Presione Enter [↵] para restablecer el contador a cero.

BATTERY MODEL

CCA

BATTERY MODEL

CCA

JIS#(NEW)	JIS#(OLD)	WET	MF	SMF
55D23R		355	480	500
55D23L		355	480	500
55D26R	N50Z	350	440	525
55D26L	N50ZL	350	440	525
60D23R		520		
60D23L		520		
65D23R		420	540	580
65D23L		420	540	580
65D26R	NS70	415	520	625
65D26L	NS70L	415	520	625
65D31R	N70	390	520	630
65D31L	N70L	390	520	630
70D23R	35-60	490	540	580
70D23L	25-60	490	540	580
75D23R		500	520	580
75D23L		500	520	580
75D26R	F100-5	490		
75D26L	F100-5L	490		
75D31R	N70Z	450	540	735
75D31L	N70ZL	450	540	735
80D23R		580		
80D23L		580		
80D26R	NX110-5	580	580	630
80D26L	NX110-5L	580	580	630
85B60K				500
85BR60K				500
95D31R	NX120-7	620	660	850
95D31L	NX120-7L	620	660	850
95E41R	N100	515	640	770
95E41L	N100L	515	640	770
105E41R	N100Z	580	720	880
105E41L	N100ZL	580	720	880
105F51R	N100Z	580		
105F51L	N100ZL	580		
115E41R	NS120	650	800	960
115E41L	NS120L	650	800	960
115F51R	N120	650	800	960
115F51L	N120L	650	800	960
130E41R	NX200-10	800		
130E41L	NX200-10L	800		
130F51R		800		
130F51L		800		
145F51R	NS150	780	920	
145F51L	NS150L	780	920	
145G51R	N150	780	900	1100
145G51L	N150L	780	900	1100
150F51R	NT200-12	640		
150F51L	NT200-12L	640		
165G51R	NS200	935	980	
165G51L	NS200L	935	980	
170F51R	NX250-12	1045		
170F51L	NX250-12L	1045		
180G51R	NT250-15	1090		
180G51L	NT250-15L	1090		
195G51R	NX300-51	1145		
195G51L	NX300-51L	1145		
190H52R	N200	925	1100	1300
190H52L	N200L	925	1100	1300
245H52R	NX400-20	1530	1250	
245H52L	NX400-20L	1530	1250	

JIS#(NEW)	JIS#(OLD)	WET	MF	SMF
26A17R		200		
26A17L		200		
26A19R	12N24-4	200	220	264
26A19L	12N24-3	200	220	264
28A19R	NT50-N24	250		
28A19L	NT50-N24L	250		
32A19R	NX60-N24	270	295	
32A19L	NX60-N24L	270	295	
26B17R		200		
26B17L		200		
28B17R		245		
28B17L		245		
28B19R	NS40S	245		
28B19L	NS40LS	245		
32B20R	NS40	270		
32B20L	NS40L	270		
32C24R	N40	240	325	400
32C24L	N40L	240	325	400
34B17R		280		
34B17L		280		
34B19R	NS40ZA	270	325	400
34B19L	NS40ZAL	270	325	400
34B19RS	NS40ZAS	270	325	400
34B19LS	NS40ZALS	270	325	400
36B20R	NS40Z	275	300	360
36B20L	NS40ZL	275	300	360
36B20RS	NS40ZS	275	300	360
36B20LS	NS40ZLS	275	300	360
38B20R	NX60-N24	330	340	410
38B20RS	NT60-N24S	330	340	410
38B20L	NX60-24L	330	340	410
38B20LS	NX60-24LS	330	340	410
40B20L		330		
40B20R		330		
42B20R		330		
42B20L		330		
42B20RS		330		
42B20LS		330		
46B24R	NS60	325	360	420
46B24L	NS60L	325	360	420
46B24RS	NS60S	325	360	420
46B24LS	NS60LS	325	360	420
46B26R	NS60	360		
46B26L	NS60L	360		
46B26RS	NS60S	360		
46B26LS	NS60LS	360		
48D26R	N50	280	360	420
48D26L	N50L	280	360	420
50B24L	NT80-S6L	390		
50B24R	NT80-S6	390		
50D20R		310	380	480
50D20L		310	380	480
50D23R	85B60K	500		
50D23L	85B60K	500		
50D26R	50D20R		370	
50D26L	50D20L		370	
55B24R	NX100-S6	435	420	500
55B24L	NX100-S6L	435	420	500
55B24RS	NT80-S6S	430	420	500
55B24LS	NT80-S6LS	430	420	500

**BATTERY
MODEL****AMPS
RATING
DIN EN****BATTERY
MODEL****AMPS
RATING
DIN EN**

57113	57114		400	680
57217	57218	57219	420	720
57220			420	720
57230			380	640
57412	57412L	57413	400	680
57512	57513	57531	350	570
58424			450	760
58513	58514		320	540
58515			450	760
58521	58522		320	540
58527			395	640
58811			440	720
58815	58820		395	640
58827			400	640
58833	58838		400	680
59017	59018	59040	360	600
59215			450	760
59218	59219		290	480
59226			450	760
59514			320	540
59518			395	640
59519			395	640
59615	59616		360	600
60018	60019		250	410
60026			440	720
60038	60044		500	760
60527	60528		410	680
61017	61018		400	680
61023	61047	61048	450	760
62034	62038	62045	420	680
62529			450	760
63013			470	680
63545	63549		420	680
64020			325	550
64028	64035		520	760
64036			460	760
64317	64318	64323	540	900
65513			540	900
65514	65515		570	900
67043	67045		600	1000
68021			570	950
68032	68034		600	1000
68040			570	950
70027	70029		630	1050
70036			570	950
70038			630	1050
71014	71015		700	1150
72512			680	1150
73011			740	1200
88038			175	300
88046			210	360
88056			265	450
88066			300	510
88156			320	540
88074	88092		400	680

52805	52815		180	240
53517			175	300
53520	53521	53522	150	240
53621	53624	53625	175	300
53638	53646	53653	175	300
53836	53890	54038	175	300
54039	54232		175	300
54312	54317	54434	210	360
54313	54324		220	330
54437	54449	54459	210	360
54459L	54465	54466	210	360
54464			220	330
54469	54519	54533	210	360
54523	54524		220	300
54537	54545		190	300
54551	54577	54578	220	300
54579	54580	54584	220	300
54590			210	330
54612			210	360
54801			190	300
54827			240	360
55040			265	450
55041	55042		220	360
55044			265	450
55046			300	360
55048			300	510
55056	55057		320	540
55068	55069		220	390
55218			255	420
55414	55415	55421	265	450
55422			265	450
55423	55427	55428	300	510
55457			265	450
55529			220	360
55530	55531	55545	255	420
55548	55552	55559	255	420
55559L	55563	55584	255	420
55565	55565L	55566	255	420
55567			255	420
55811			360	540
56012			230	420
56048	56049	56068	250	390
56069	56073		250	390
56077	56092		300	510
56091			360	540
56111			300	540
56216	56218	56219	300	510
56220			280	510
56225	56311	56312	300	510
56318	56322	56323	300	510
56420	56530	56618	300	510
56619	56620	56633	300	510
56638	56641	56647	300	510
56821	56820	56828	315	540
57024	57029		315	540

BATTERY MODEL	AH	CCA WET AGM	BATTERY MODEL	AH	CCA WET AGM	BATTERY MODEL	AH	CCA WET AGM	BATTERY MODEL	AH	CCA WET AGM
51814	18	100	YB5L-B	5	65	YT4L-4	3	50	YTZ12S-BS	11	210
51913	19	100	YB7-A	8	124	YT7B-4	6.5	110	YTZ14S	11.2	230
53030	30	180	YB7C-A	8	124	YT7B-BS	6.5	110	YTZ14S-BS	11.2	230
12N5-3B	5	39	YB7L-B	8	124	YT9B-4	8	120			
12N5.5-3B	5.5	40	YB9A-A	9	124	YT9B-BS	8	120	TTZ7S-BS	6	130
12N5.5-4A	5.5	60	YB9-B	9	130	YT12A-BS	10	175	TTZ10S	8.6	190
12N5.5-4B	5.5	60	YB9L-A2	9	130	YT12B-BS	10	210	TTZ12S-BS	11	210
12N5.5A-3B	5.5	58	YB9L-B	9	130	YT12B-4	10	210	TTZ14S-BS	11.2	230
12N7-3B	7	74	YB9L-A2	9	130	YT14B-BS	10	210			
12N7-4A	7	74	YB10A-A2	11	160	YTR4A-BS	2.3	45			
12N7-4B	7	74	YB10L-A2	11	160	YTR9-4	10	175	POWER MAX		
12N7D-3B	7	74	YB10L-B	11	160	YTR9-BS	10	175	GT4L-BS	3	50
12N9-3A	9	85	YB10L-B2	11	160	YTR9-4	10	175	GT5L-BS	4	70
12N9-3B	9	85	YB12A-A	12	165	YTX4L-BS	3	50	GTX7A-BS	6	90
12N9-4B-1	9	85	YB12A-B	12	165	YTX5L-BS	4	80	GT7B-4	6.5	85
12N10-3A	11	160	YB12AL-A	12	165	YTX5L-4	4	80	GT7L-BS	6	85
12N10-3A-1	11	160	YB12AL-A2	12	165	YTX7A-BS	6	105	GTZ7S	6	130
12N10-3A-2	11	103	YB12B-B2	12	165	YTX7L-BS	6	100	GT9B-4	8	115
12N11-3A-1	11	128	YB12C-A	12	165	YTX9-BS	8	135	GTY9-BS	8	120
12N12A-4A-1	12	113	YB14-A2	14	190	YTX12-4	10	180	GTZ10S	8.6	190
12N14-3A	14	128	YB14A-A1	14	190	YTX12-BS	10	180	GT12B-4	11	125
12N20AH	18	100	YB14A-A2	14	190	YTX14-4	12	200	GTX12A-BS	10	175
12N24-3	24	200	YB14-B2	14	190	YTX14-BS	12	200	GTX12-BS	10	180
12N24-3A	24	200	YB14L-A1	14	190	YTX14AH-BS	12	210	GTZ12S	11	210
HYB16A-AB	16	210	YB14L-A2	14	190	YTX14L-4	12	200	GTZ14S	11.2	230
SYB14L-A2	14	190	YB14L-B2	14	190	YTX15L-BS	13	230	GT14B-4	12	210
SY50-N18L-AT	20	260	YB16L-A2	16	200	YTX16-BS	14	230	GTX14AH-BS	12	210
Y50-N18A-A	20	260	YB16-B	19	240	YTX16-4-1	14	230	GTX14AHL	12	210
Y50-N18L-A	20	260	YB16B-A	16	207	YTX16-BS-1	14	230	GTX14L-BS	12	200
Y50-N18L-A2	20	260	YB16B-A1	16	207	YTX20-4	18	270	GTX14-BS	12	200
Y50-N18L-A3	20	260	YB16-B-CX	19	240	YTX20-BS	18	270	GTX15L-BS	13	210
Y60-N24-A	28	300	YB16CL-B	19	240	YTX20L-4	18	270	GTX16-BS	14	230
Y60-N24L-A	28	300	YB16HL-A-CX	18	270	YTX20L-BS	18	270	GTX16-BS-1	14	230
Y60-N24AL-B	30	180	YB16L-B	19	240	YTX24HL-BS	21	350	GTX16CLB-BS	19	310
YB2.5L-C	2.5	19	YB18-A	18	235	YTZ6	5	90	GTX20-BS	18	270
YB2.5L-C-1	2.5	19	YB18L-A	18	235	YTZ6S-BS	5	90	GTX20CH-BS	18	270
YB2.5-C-2	2.5	19	YB30CL-B	30	300	YTZ7S	6	130	GTX20HL-BS	18	310
YB3L-A	3	32	YHD-12	28	240	YTZ7S-BS	6	130	GTX20L-BS	18	270
YB3L-B	3	32	YIX30L	30	385	YTZ10S	8.6	190	GIX50L-BS	21	350
YB4L-A	4	56	YT4B-4	2.3	40	YTZ10S-BS	8.6	190	GTX24HL-BS	21	350
YB4L-B	4	56	YT4B-BS	2.3	40	YTZ12S	11	210	GIX30L-BS	30	385

BATTERY MODEL | **AH** | **CCA WET AGM** | **BATTERY MODEL** | **AH** | **CCA WET AGM**

BATTERY MODEL | **AH** | **CCA WET AGM** | **BATTERY MODEL** | **AH** | **CCA WET AGM**

ADVENTURE POWER			WP12A-BS	9.5	175
HUB16A-AB	16	190	WP12-B	10	220
UT4L-BS	3	35	WP12B-4	10	225
UT5L	4	55	WPZ12S	11	250
UTZ7S	6	90	WP14B-4	12	180
UTX7A	6	85	WPZ14S	11.2	250
UTX7L	6	85	WP14-B	12	210
UTB-4	6	85	WP14L-2	12	210
UTX9	8	120	WPX14AH-BS	12	210
UTX9B-4	8	115	WPX15L-BS	13	300
UTZ10S	8.6	150	WPH16	14	230
UT12B-4	10	130	WPH16	14	230
UTX12	10	150	WP16L-B	19	230
UBVT-8	12	200	WP16L-B	20	325
UTX14AH	14	190	WPX20L-BS	18	310
UTX14AHL	12	190	WPX20-BS	18	310
UBVT-3	12	200	WP20-12I	20	325
UTX14B-14	12	145	WP50N18L-A	21	350
UBTZ14S	11.2	175	WP50N18L-A3	22	350
UTX14	14	200	WESTCO		
UTX16-1	14	200	12VX4LB	4	45
UT16B	19	240	12VX5LB	5	70
UT16L-B	19	240	12V7LB	7	85
UBVT-4	19	240	12V7B-B	7	85
UBVT-5	19	240	12V7A-BS	7	90
UT16CL	19	190	12VZ7S	7	130
UTX20	18	250	12V9B-4	8	115
UBVT-1	18	310	12V9-B	9	120
UB22-12N	22	420	12VZ10S	9	190
UBVT-6	22	350	12V12B-4	10	125
UBVT-2	30	385	12V12A-BS	11	175
UBVT-7	28	240	12V12-B	10	180
POWER SOURCE			12V13L	13	275
WP4L-B	3	80	12V14-B	14	200
WP5L-B	4	80	12V14B-4	12	135
WP7L-B	6	140	12V14L-B	14	200
WP7A-B	6	90	12V14-A2	14	210
WP7B-4	6.5	125	12V16-B	14	230
WPZ7S	6	180	12V16-A2	14	230
WP9-B	8	180	12V16CLB	19	260
WP9B-1	8	180	12V20P	20	275
WPZ10S	8.6	225	12V20	18	300

12V20L	18	300	SHORAI		
12V22	22	350	LFX07L2-BS12	7	102
12V30	30	350	LFX09L2-BS12	9	135
12VX30L-B	30	350	LFX09A2-BS12	9	135
			LFX12A1-BS12	12	155
BIG CRANK			LFX14A1-BS12	14	210
ETX9	8	120	LFX14A2-BS12	14	210
ETX12	10	180	LFX14A4-BS12	14	210
ETX14	12	220	LFX14A5-BS12	14	210
ETX15	14	220	LFX14L-BS12	14	210
ETX15L	14	220	LFX14L2-BS12	14	210
ETX16	19	325	LFX14A4-BS12	14	210
ETX16L	19	325	LFX14A5-BS12	14	210
ETX18L	20	340	LFX14L5-BS12	14	210
ETX20L	17.5	310	LFX14L2-BS12	14	210
ETX30L	26	400	LFX18A1-BS12	18	270
			LFX18L1-BS12	18	270
ODYSSEY			LFX21A6-BS12	21	315
PC310	8	100	LFX21L6-BS12	21	315
PC535	14	200	LFX24A3-BS12	24	360
PC545	13	150	LFX24L3-BS12	24	360
PC625	18	200	LFX27A3-BS12	27	405
PC680	16	170	LFX27L3-BS12	27	405
PC925	28	330	LFX36A3-BS12	36	540
PC1200	42	540	LFX36L3-BS12	36	540

T13

ADVANCED BATTERY TESTER