

WT1500NT WT1500NT-B

Capacity 1500 kg

Capacity 1500 kg

WT1500N

Capacity 1500 kg



DK **Brugermanual**
Hjulløfter

GB **User's guide**
Wheel Removal Trolley

DE **Betriebsanleitung**
Radmontagegerät



AC Hydraulic A/S
Fanøvej 6
DK-8800 Viborg - Danmark
Tel.: +45 8662 2166
Fax: +45 8662 2988
E-mail: ac@ac-hydraulic.dk
www.ac-hydraulic.com

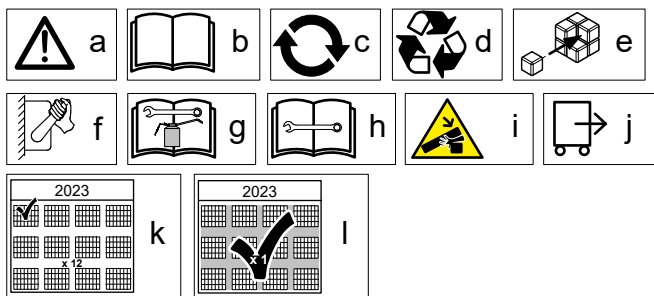

(DK) (NO) Original tekst

Produktbeskrivelse

Denne maskine er konstrueret med følgende komponenter:

Søjle

- Hydraulikcylinder
- Pumpe enhed
- Olietank
- Bærende struktur
- Ruller
- Hjul

Tilsligtet anvendelse

Hjulløfteren må kun anvendes til løft af hjul – ikke til løft af selve køretøjet (Fig.3).

Manualens formål

Denne manual indeholder følgende information:

- Sikkerhedsforanstaltninger og advarsler
- Maskinspecifikationer
- Samlevejledninger
- Betjeningsvejledninger
- Vedligeholdelse og servicevejledninger
- Sikkerhedseftersyn
- Fejlfinding
- Detaljerede tegninger og reservedelslister
- Hydraulik diagram
- Tilbehør
- CE Overensstemmelseserklæring

SYMBOLFORKLARING

- a** ADVARSEL! Risiko for alvorlig personskade eller dødsfald for brugeren eller andre. Vær forsigtig, og brug produktet korrekt
- b** Læs brugsanvisningen omhyggeligt igennem, og sørg for at have forstået vejledningen før brug af produktet (Fig.1)
- c** Udskift beskadigede, slidte eller defekte dele
- d** Overhold de lokale krav til genanvendelse og de gældende regler.
- e** Montering
- f** Betjening
- g** Vedligehold
- h** Fejlfinding
- i** Klemningsfare
- j** Transport
- k** Månedelig vedligehold
- l** Sikkerhedsmæssige eftersyn

(GB) Translation of original text

Product description

This machine has been built with the following components:

- Column
- Hydraulic cylinder
- Pump
- Reservoir
- Supporting structure
- Rollers
- Wheels

Intended use

The wheel trolley is for lifting wheels only – not for lifting vehicles (Fig.3).

Purpose of the manual

This guide contains or describes the next topics:

- Safe usage instructions and warnings
- Machine specifications
- Assembly
- Operation
- Maintenance
- Safety inspection
- Troubleshooting
- Detail drawings and spareparts
- Hydraulic diagram
- Accessories
- EC Declaration of Conformity for Machinery

KEY TO SYMBOLS

- a** WARNING! Be careful and use the product correctly. This product can cause serious injury or death to the operator or others.
- b** Please read the operator's manual carefully and make sure that you understand the instructions before use (Fig.1).
- c** Replace damaged, worn or broken parts
- d** Obey the local recycling requirements and applicable regulations.
- e** Assembly
- f** Operation
- g** Maintenance
- h** Troubleshooting
- i** Crush hazard
- j** Transportation
- k** Monthly maintenance
- l** Safety inspection

(DE) Übersetzung des Originaltextes

Produktbeschreibung

Diese Maschine wurde mit folgenden Komponenten gebaut:

- Säule
- Hydraulischer Zylinder
- Pumpe
- Bedienfeld
- Ölbehälter
- Unterstützende Struktur
- Rollen
- Räder

Vorgesehene Verwendung

Das Radmontagegerät ist nur für das Anheben von Rädern einsetzbar – nicht vom Fahrzeug (Fig.3).

Zweck des Handbuchs

Dieses Handbuch enthält oder beschreibt die folgenden Themen:

- Sicherheitsvorschriften und Warnungen
- Maschinenspezifikationen
- Montage
- Bedienung
- Wartung
- Sicherheitsinspektion
- Fehlersuche und -behebung
- Detailzeichnungen und Ersatzteile
- Hydraulisches diagramm
- Zubehör
- EG Konformitätserklärung

SYMBOLERKLÄRUNG

- a** WARNUNG! Gehen Sie vorsichtig vor, und verwenden Sie das Gerät ordnungsgemäß. Dieses Gerät kann schwere oder tödliche Verletzungen des Bedieners oder anderer Personen verursachen.
- b** Lesen Sie die Bedienungsanleitung sorgfältig durch, und machen Sie sich vor der Benutzung mit dem Inhalt vertraut (Fig. 1).
- c** Ersetzen Sie beschädigte, abgenutzte oder defekte Teile.
- d** Befolgen Sie die örtlichen Recyclinganforderungen und geltenden Vorschriften.
- e** Montage
- f** Betrieb
- g** Wartung
- h** Fehlersuche und -behebung
- i** Quetschgefahr
- j** Transport
- k** Monatliche Wartung
- l** Sicherheitsinspektion

(FR) Traduction du texte original

Description du produit

Cette machine a été construite avec les composants suivants:

- Colonne
- Vérin hydraulique
- Pompe
- Réservoir
- Structure de support
- Rouleaux
- Roues

Utilisation prévue

Le chariot hydraulique ne peut servir qu'à soulever une roue, pas le véhicule (Fig. 3).

But du manuel

Ce guide contient ou décrit les sujets suivants:
Instructions d'utilisation et avertissements sécuritaires

- Spécifications de la machine
- Assemblage
- Utilisation
- Maintenance
- Inspection de sécurité
- Guide de dépannage
- Dessins de détail et pièces de rechange
- Schéma hydraulique
- Accessoires
- Déclaration CE de conformité pour les composants

EXPLICATION DES SYMBOLES

- a** AVERTISSEMENT ! Soyez prudent et utilisez le produit correctement. Ce produit peut causer des blessures graves, voire mortelles, à l'opérateur ou à d'autres personnes.
- b** Veuillez lire attentivement le manuel d'utilisation et assurez-vous de bien comprendre les instructions avant utilisation (Fig. 1).
- c** Remplacez les pièces endommagées, usées ou cassées.
- d** Respectez les consignes locales de recyclage et la réglementation en vigueur.
- e** Montage
- f** Utilisation
- g** Maintenance
- h** Guide de dépannage
- i** Risque d'écrasement
- j** Transport
- k** Maintenance mensuel
- l** Inspection de sécurité

(SE) Översättning av originaltext

Produktbeskrivning

Denna maskin är byggd med följande komponenter:

- Pilare
- Hydraulcylinder
- Pump
- Tank
- Stödstruktur
- Rullar
- Hjul

Avsedd användning

Hjullyften får endast användas för att lyfta hjul, inte till att lyfta själva fordonet (Fig. 3).

Syftet med manualen

Den här guiden innehåller eller beskriver följande ämnen:

- Instruktioner för säker användning och varningar
- Maskinspecifikationer
- Montering
- Drift
- Underhåll
- Säkerhetsunderhåll
- Felsökning
- Detaljritningar och reservdelar
- Hydrauliskt diagram
- Tillbehör
- EU Överensstämmelseförsäkran

SYMBOLFÖRKLARING

- a** VARNING! Var försiktig och använd produkten på rätt sätt. Den här produkten kan orsaka allvarlig eller livshotande skada för användaren och andra.
- b** Läs igenom bruksanvisningen noggrant och se till att du förstår instruktionerna innan användning (Fig. 1).
- c** Byt ut skadade, slitna och trasiga delar.
- d** Följ lokala återvinningsbestämmelser och tillämpliga förordningar.
- e** Montering
- f** Drift
- g** Underhåll
- h** Felsökning
- i** Krossfara
- j** Transport
- k** Månatligt underhåll
- l** Säkerhetsunderhåll

(FI) Alkuperäisen tekstin käännös

Tuotekuvaus

Tämä kone on rakennettu seuraavista komponenteista:

- Sarake
- Hydraulisylinteri
- Pumppu
- Säiliö
- Tukirakenne
- Rulla
- Pyörät

Käyttötarkoitus

Rengasnostinta saa käyttää vain renkaiden nostamiseen – ei ajoneuvon nostamiseen (Fig. 3).

Käsikirjan tarkoitus

Tämä opas sisältää tai kuvaa seuraavia aiheita:

- Turvallisuusohjeet ja varoitukset
- Koneen tekniset tiedot
- Asentaminen

- Käyttö
- Kunnossapito
- Turvatarkastukset
- Vianmääritys
- Yksityiskohtaiset piirustukset ja varaosat
- Hydraulinen kaavio
- Lisätarvikkeet
- EU Vaatimustenmukaisuuvakuutus

MERKKIEN SELITYKSET

- a** VAROITUS! Ole varovainen ja käytä laitetta oikein. Tämä laite voi aiheuttaa käyttäjälle tai sivullisille vakavia vahinkoja tai kuoleman.
- b** Lue käyttöohje huolellisesti ja varmista, että ymmärrät sen sisällön, ennen kuin alat käyttää konetta (Fig. 1).
- c** Vaihda vaurioituneet, kuluneet tai rikkoutuneet osat.
- d** Noudata paikallisia kierrätysvaatimuksia ja säädöksiä.
- e** Asentaminen
- f** Käyttö
- g** Kunnossapito
- h** Vianmääritys
- i** Murskausvaara
- j** Kuljetus
- k** Kuukausittainen huolto
- l** Turvatarkastukset

(NL) Vertaling van originele tekst

Productbeschrijving

Deze machine is gebouwd met de volgende componenten:

- Kolom
- Hydraulische cylinder
- Pomp
- Reservoir
- Ondersteunende structuur
- Rollers
- Wielen

Gebruiksdoeleinden

De wielheffer is uitsluitend voor het heffen van wielen en niet voor het heffen van voertuigen (Fig. 3).

Doel van de handleiding

Deze gids bevat of beschrijft de volgende onderwerpen:

- Instructies voor veilig gebruik en Instructies
- Machine specificaties
- Assemblage
- Werking
- Onderhoud
- Inspectie van de veiligheid
- Storingzoeken
- Detailtekeningen en onderdelen
- Hydraulisch schema
- Accessoires
- EU Verklaring van overeenstemming

VERKLARING VAN DE SYMBOLEN

- a** WAARSCHUWING! Wees voorzichtig en gebruik het product op de juiste manier. Dit product kan ernstig of fataal letsel toebrengen aan de gebruiker of anderen.
- b** Lees de bedieningshandleiding zorgvuldig door en zorg dat u de instructies hebt begrepen voordat u het product gebruikt (Fig. 1).
- c** Vervang beschadigde, versleten of defecte onderdelen.
- d** Neem de plaatselijk geldende wet- en regelgeving voor recycling in acht.
- e** Montage
- f** Werking
- g** Onderhoud
- h** Storingzoeken
- i** Gevaar voor beknelling

- j** Vervoer
- k** Maandelijks onderhoud
- l** Inspectie van de veiligheid

(ES) Traducción del texto original

Descripción del producto

Esta máquina ha sido construida con los siguientes componentes:

- Columna
- Cilindro hidráulico
- Bomba
- Tanque de depósito de aceite
- Estructura de soporte
- Ruedas
- Rodillos

Uso previsto

El carro para ruedas es para levantar ruedas únicamente, no para levantar vehículos (Fig. 3).

Propósito del manual

Esta guía contiene o explica los siguientes tópicos:

- Instrucciones de seguridad y advertencias
- Especificaciones de la máquina
- Montaje
- Funcionamiento
- Mantenimiento
- Inspección de seguridad
- Planos de detalle y lista de repuestos
- Diagrama hidráulico
- Accesorios
- EU declaración de conformidad sobre maquinaria

DEFINICIÓN DE LOS SÍMBOLOS

- a** ADVERTENCIA: Tenga cuidado y utilice el producto correctamente. Este producto puede ocasionar lesiones graves o mortales tanto al operador como a cualquier otra persona.
- b** Lea detenidamente el manual de usuario y asegúrese de que entiende las instrucciones antes de usar la máquina (Fig. 1).
- c** Cambie las piezas dañadas, desgastadas o rotas.
- d** Respete los requisitos de reciclaje locales y las normas aplicables.
- e** Montaje
- f** Funcionamiento
- g** Mantenimiento
- h** Solución de problemas
- i** Peligro de aplastamiento
- j** Transporte
- k** Mantenimiento mensual
- l** Inspección de seguridad

(RU) Перевод оригинального текста

Описание изделия

Эта машина была построена из следующих компонентов:

- Столбец
- Гидравлический цилиндр
- Насос
- Резервуар
- Несущая конструкция
- Валки
- Колеса

Предназначение

Колесная тележка предназначена только для подъема колес - не для подъема транспортных средств (Fig. 3).

Цель руководства

Это руководство содержит или объясняет следующие темы:

- Предупреждения и инструкции по безопасному применению
- Технические характеристики машины
- Сборка
- Эксплуатация
- Техническое обслуживание
- Проверка обеспечения безопасности
- Диагностика неисправностей
- Детальные чертежи и запчасти
- Гидравлическая схема
- Аксессуары

УСЛОВНЫЕ ОБОЗНАЧЕНИЯ НА ИЗДЕЛИИ

- a** ПРЕДУПРЕЖДЕНИЕ! Соблюдайте осторожность и правила эксплуатации изделия. Изделие может стать причиной тяжелой травмы или смерти оператора и окружающих.
- b** Перед началом работы внимательно прочитайте руководство по эксплуатации и убедитесь, что понимаете приведенные здесь инструкции (*Fig. 1*).
- c** Замените поврежденные, сломанные или изношенные детали.
- d** Соблюдайте местное законодательство и действующие нормы в области переработки.
- e** Сборка
- f** Эксплуатация
- g** Техническое обслуживание
- h** Диагностика неисправностей
- i** Опасность раздавить
- j** Транспорт
- k** Ежемесячное обслуживание
- l** Проверка обеспечения безопасности

IT Traduzione del testo originale

Descrizione del prodotto

Questa macchina è stata costruita con i seguenti componenti:

- Colonna
- Cilindro idraulico
- Pompa
- Serbatoio
- Struttura di supporto
- Rulli
- Ruote

Utilizzo previsto

Il sollevatore di ruote serve solo per il sollevamento di ruote, non per il sollevamento di veicoli (*Fig. 3*).

Scopo del manuale

Questa guida contiene o descrive i seguenti argomenti:

- Istruzioni per un uso sicuro e avvertenze
- Specifiche della macchina
- Montaggio
- Operazione
- Manutenzione
- Controllo di sicurezza
- Risoluzione dei problemi
- Disegni dettagliati e pezzi di ricambio
- Schema idraulico
- Accessori
- Dichiarazione di conformità UE

SIMBOLOGIA

- a** AVVERTENZA! Prestare attenzione e utilizzare il prodotto correttamente. Il prodotto può causare gravi lesioni o morte dell'operatore o altre persone.
- b** Prima dell'uso, leggere per intero il manuale dell'operatore e accertarsi di aver compreso le istruzioni (*Fig. 1*).
- c** Sostituire le parti danneggiate, usurate o rotte.
- d** Rispettare le norme locali sul riciclaggio e le normative vigenti.
- e** Montaggio
- f** Utilizzo
- g** Manutenzione
- h** Risoluzione dei problemi
- i** Pericolo di schiacciamento
- j** Transporti
- k** Manutenzione mensile
- l** Controllo di sicurezza



- (DK) (NO) ADVARSLER – sikkerhedsforanstaltninger
- (GB) WARNINGS – Safe usage instructions
- (DE) WARNUNGEN – Sicherheitsvorschriften
- (FR) AVERTISSEMENTS – Instructions pour une utilisation de toute sécurité
- (SE) VARNINGAR – instruktioner för säker användning
- (FI) VAROITUKSET – Turvallisuusohjeet
- (NL) WAARSCHUWING – Instructies voor veilig gebruik
- (ES) ADVERTENCIAS – Instrucciones de seguridad
- (IT) AVVERTENZA – istruzioni per un uso sicuro
- (RU) ПРЕДУПРЕЖДЕНИЯ – Инструкции по безопасному применению

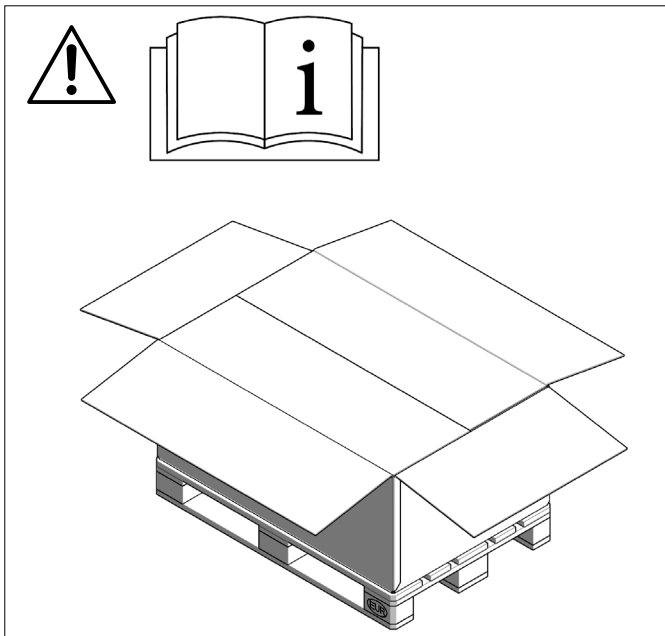

Fig.1



Fig.2

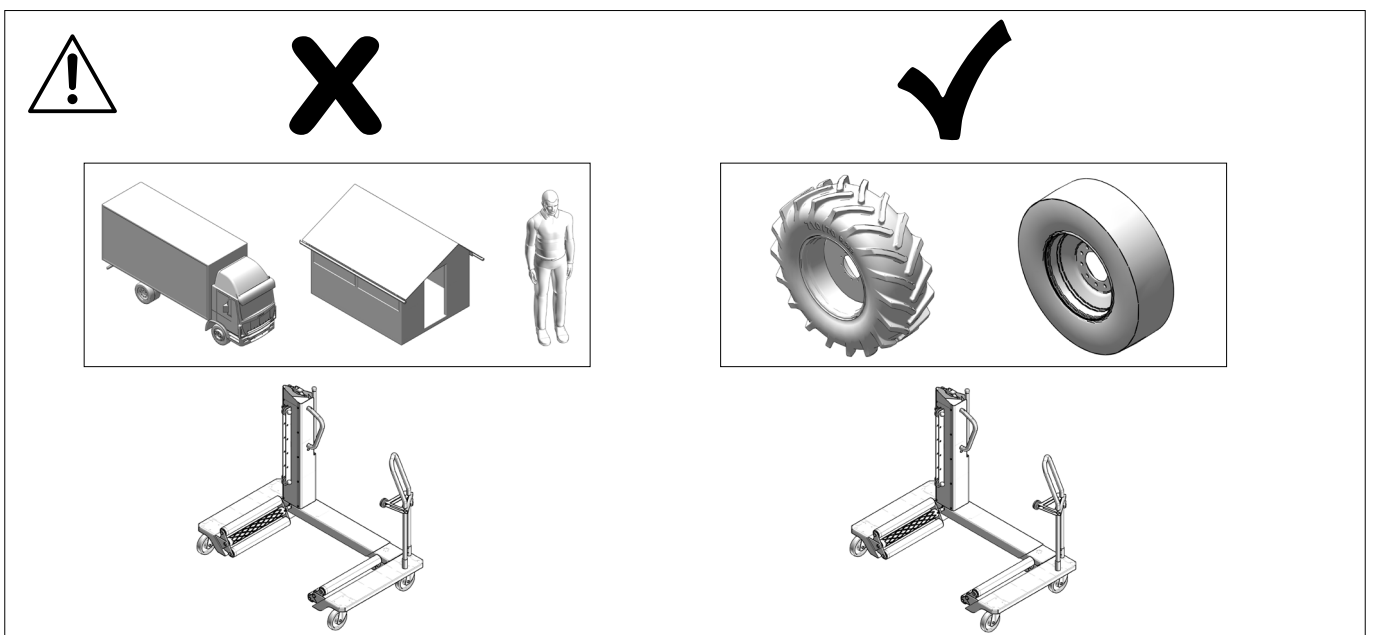

Fig.3

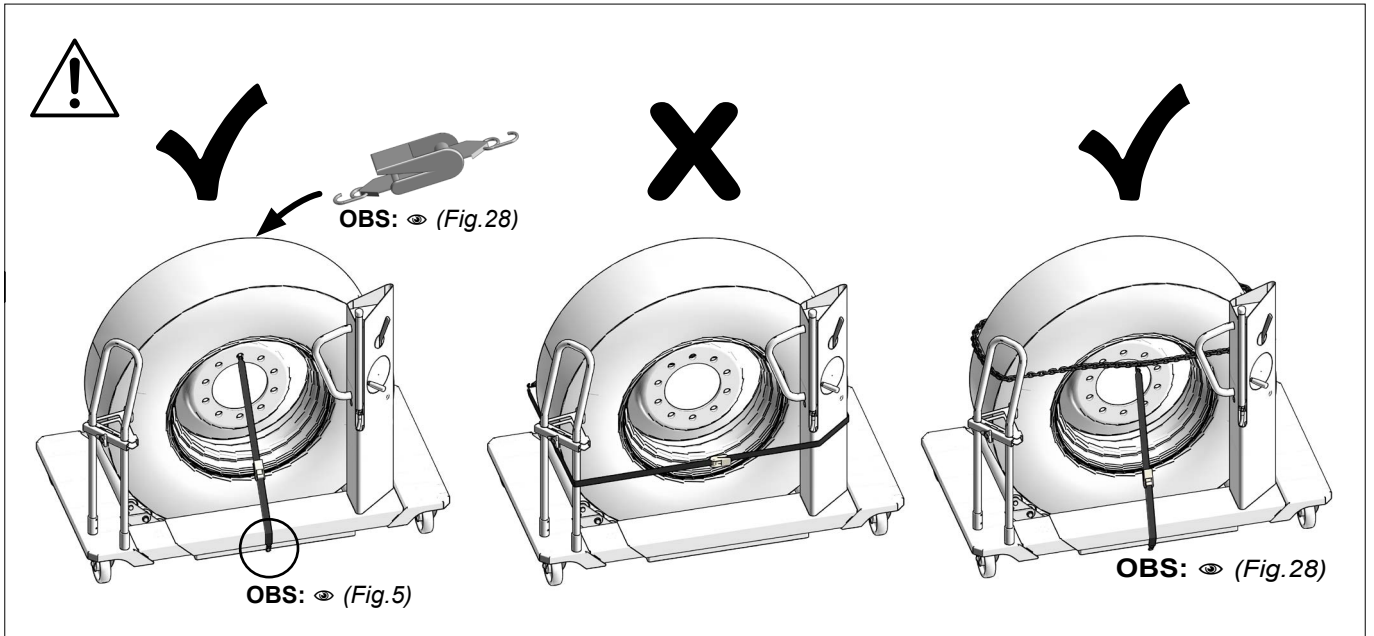

Fig.4

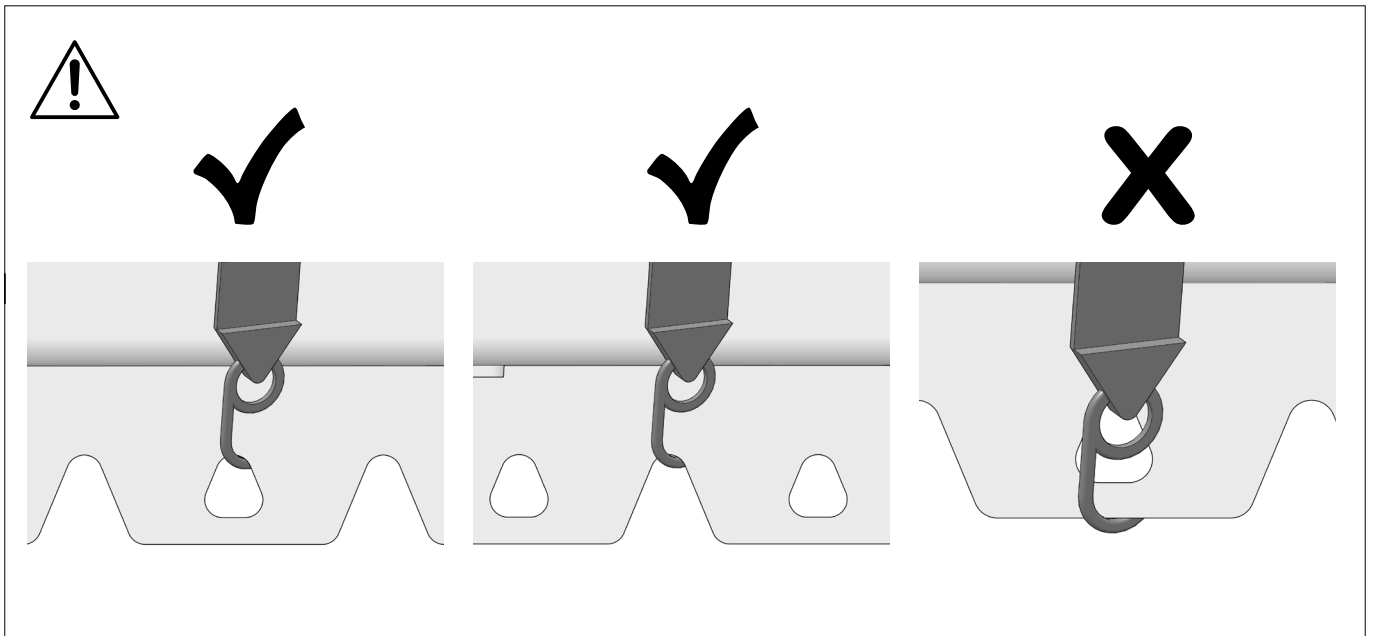

Fig.5

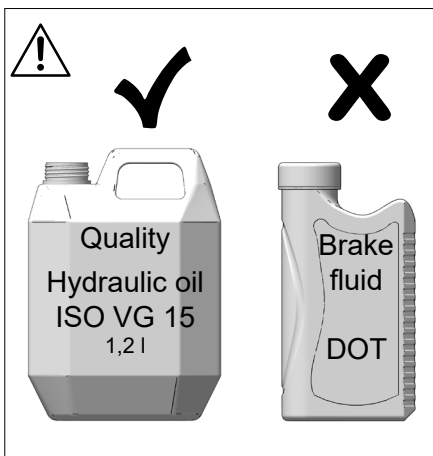

Fig.6

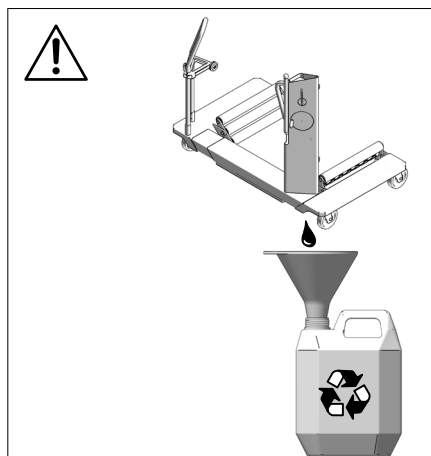

Fig.7

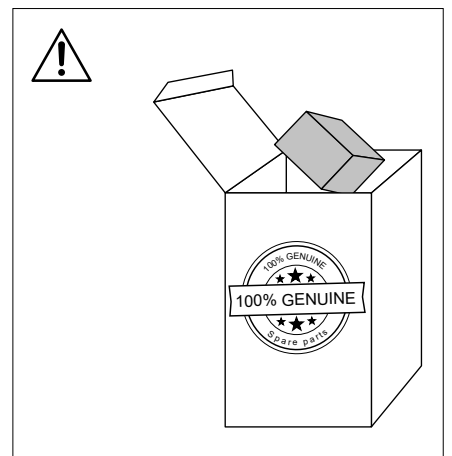
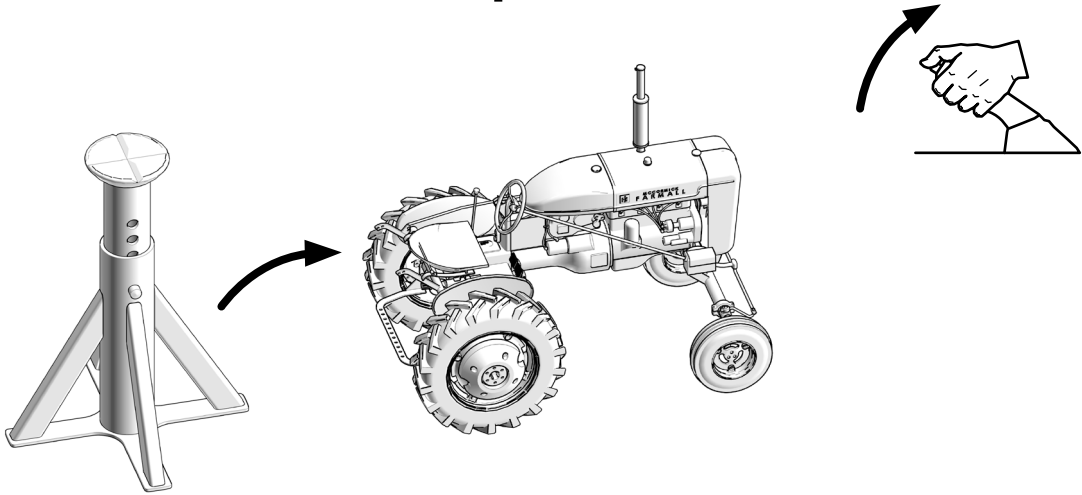

Fig.8



1



2

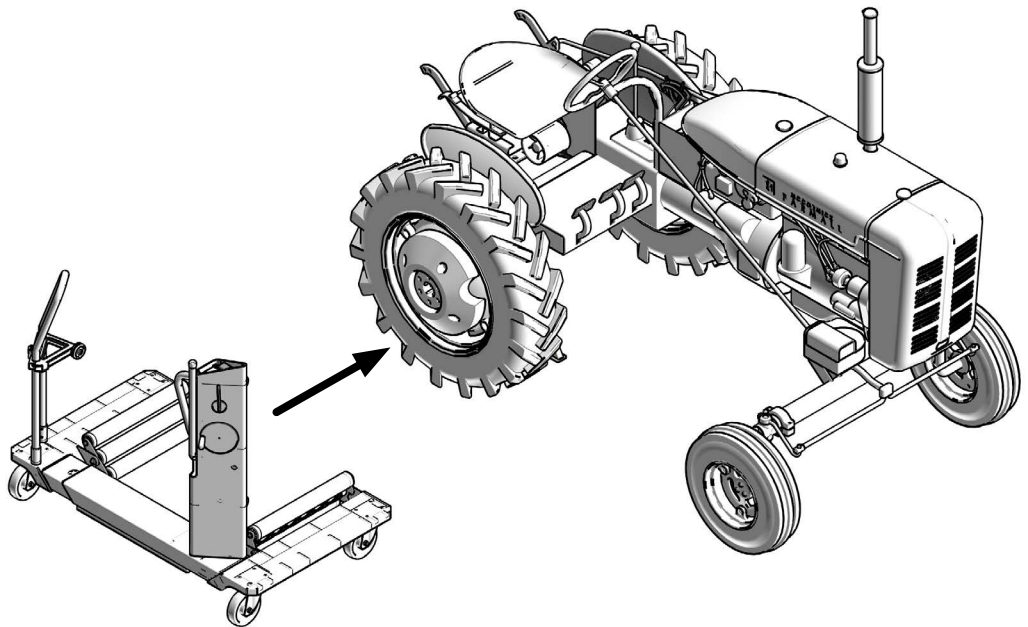

3

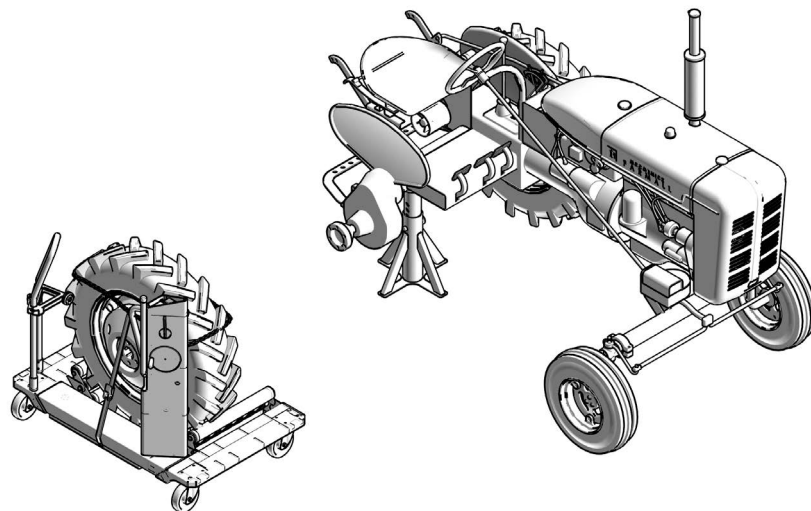

Fig.9

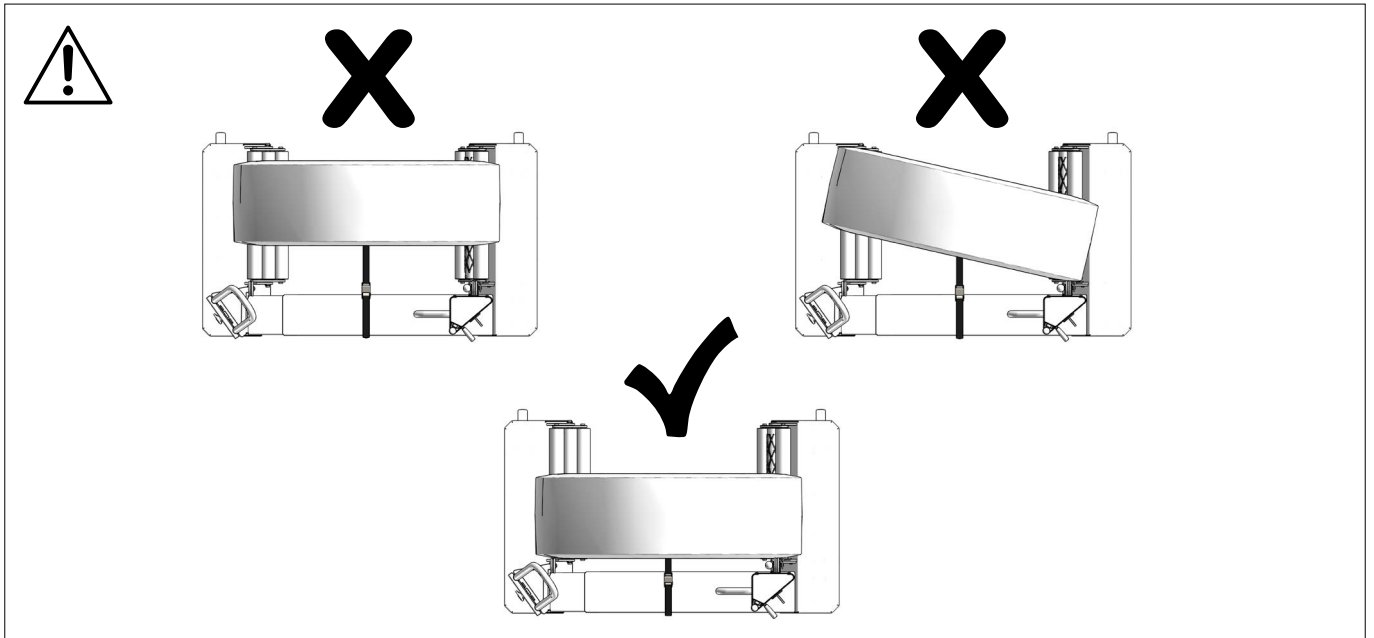

Fig.10

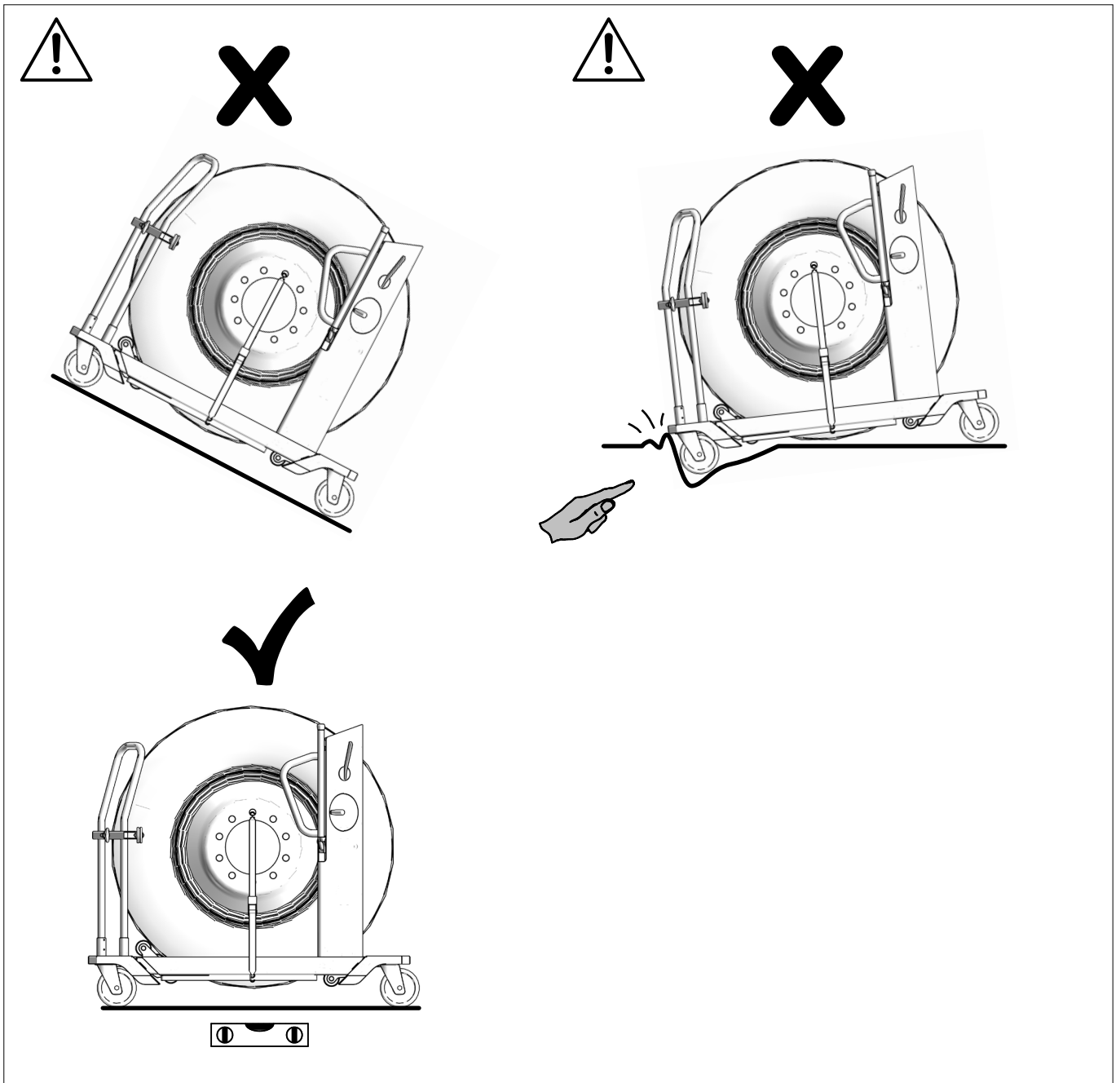
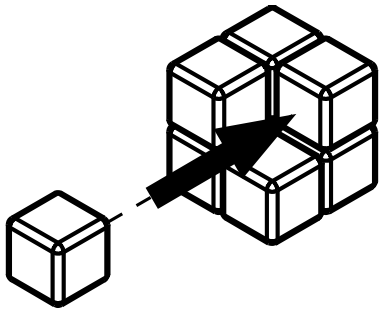

Fig.11



- ⓀⓃ ⓃⓄ **Montering**
- ⓀⓃ ⓀⓄ **Assembly**
- ⓀⓃ ⓀⓄ **Montage**
- ⓀⓃ ⓀⓄ **Assemblage**
- ⓀⓃ ⓀⓄ **Montering**
- ⓀⓃ ⓀⓄ **Asentaminen**
- ⓀⓃ ⓀⓄ **Assemblage**
- ⓀⓃ ⓀⓄ **Montaje**
- ⓀⓃ ⓀⓄ **Montaggio**
- ⓀⓃ ⓀⓄ **Сборка**

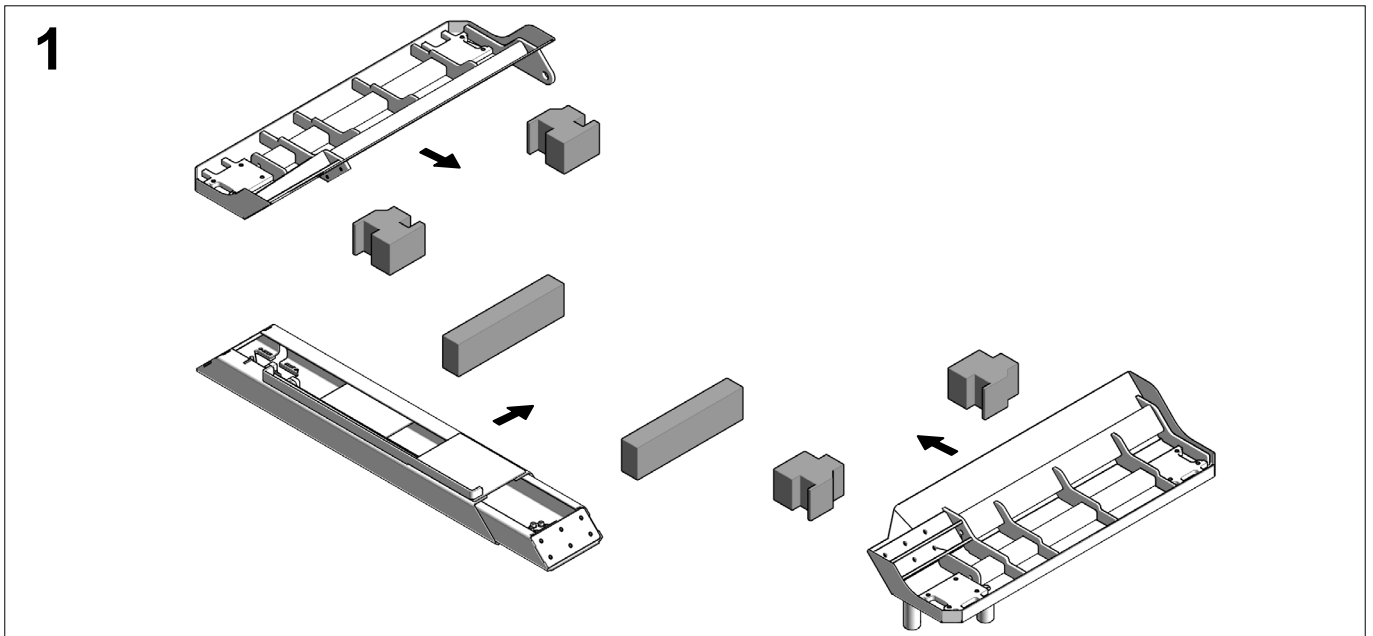

Fig.12

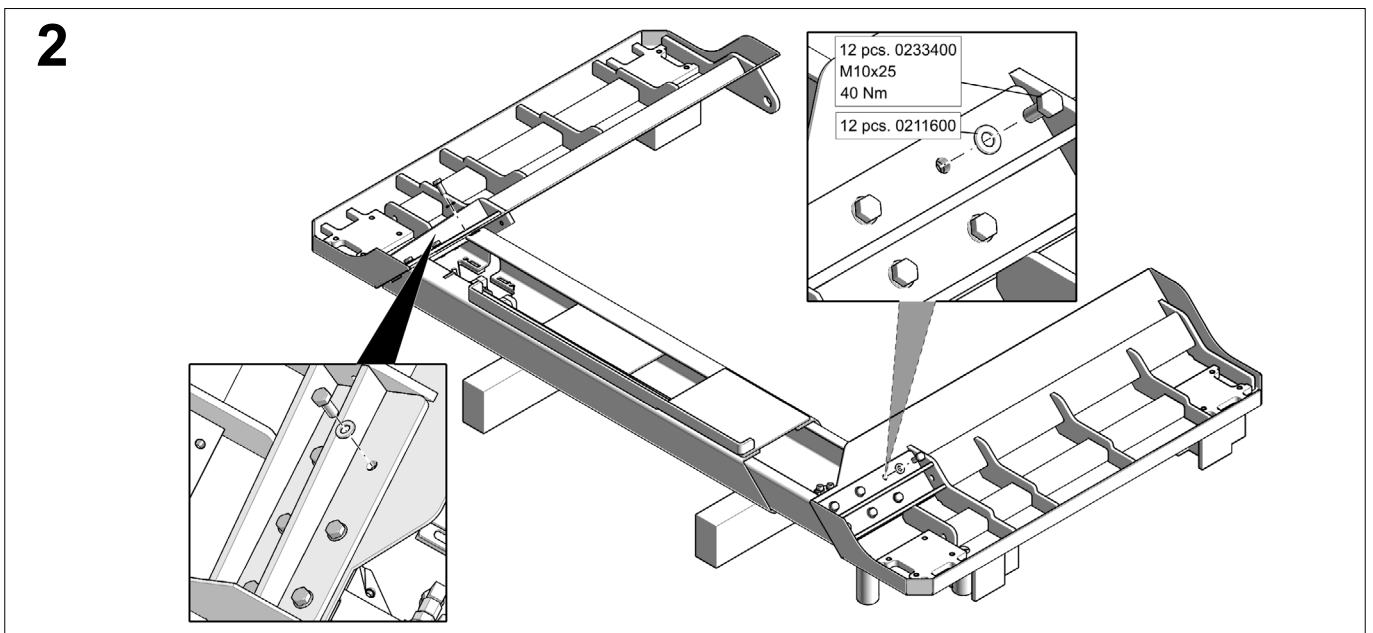

Fig.13

3

**WT1500NT
WT1500N**

WT1500NT-B → (Fig.15), (Fig.16)

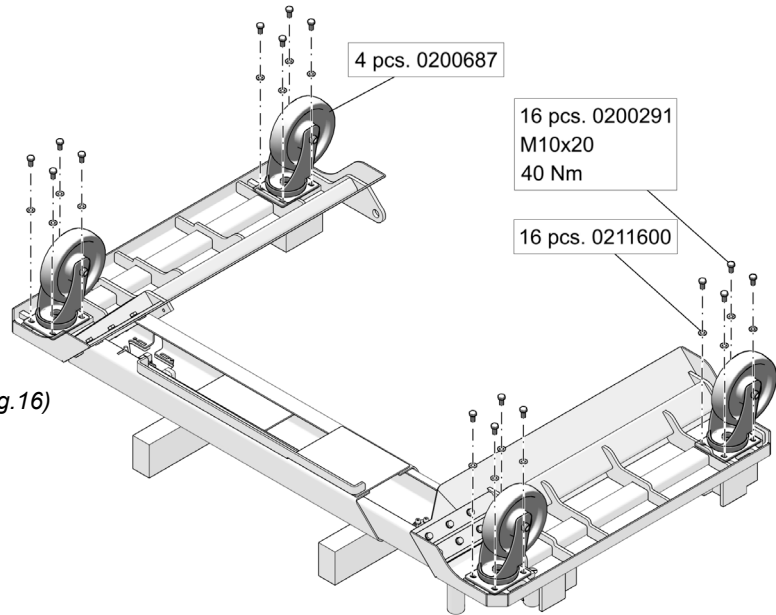

Fig.14

3

WT1500NT-B

8 pcs. 0200291
M10x20
47 Nm

16 pcs. 0211600

2 pcs. 0200736

8 pcs. 0231200
M10x25
47 Nm

2 pcs. 6102202

8 pcs. 0200230
M10x35
65 Nm

2 pcs. 0200687

2 pcs. 6102201

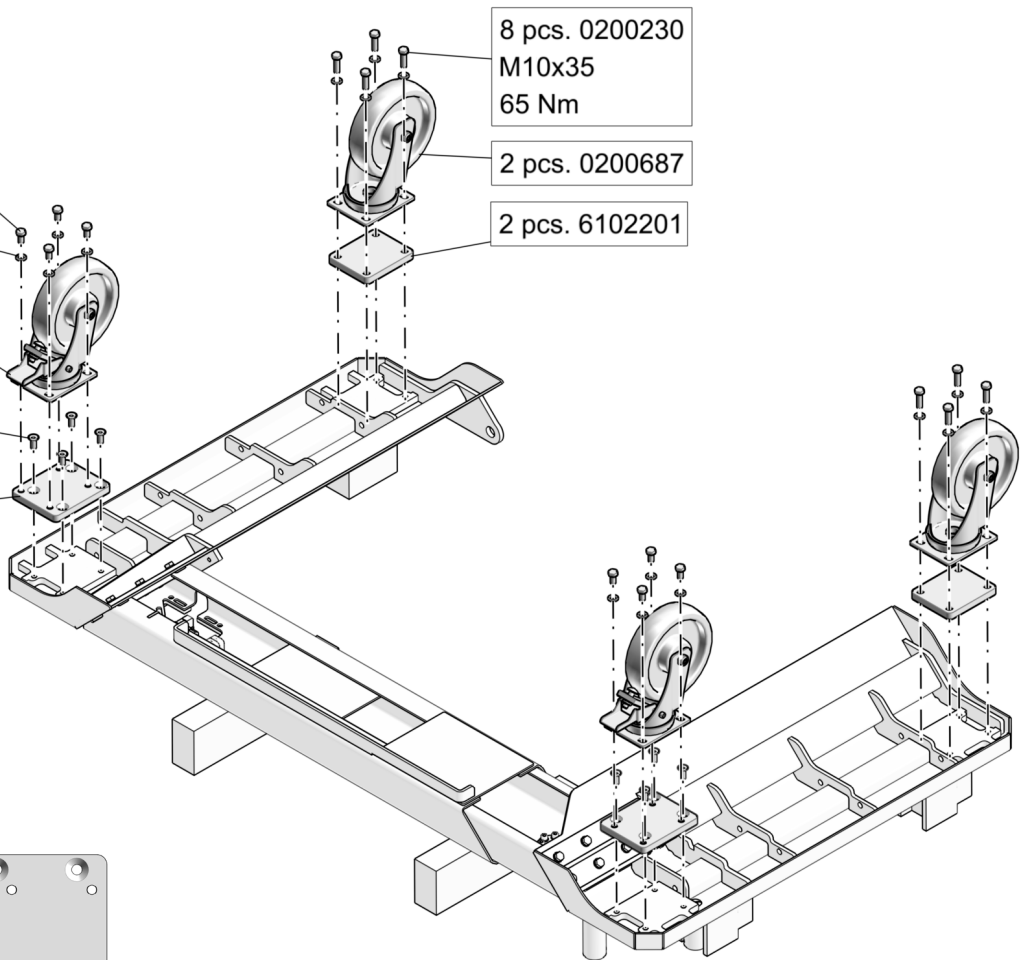
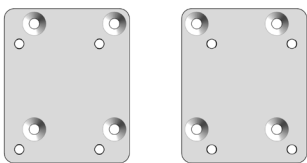

👁 (Fig.16)



Fig.15

WT1500NT-B

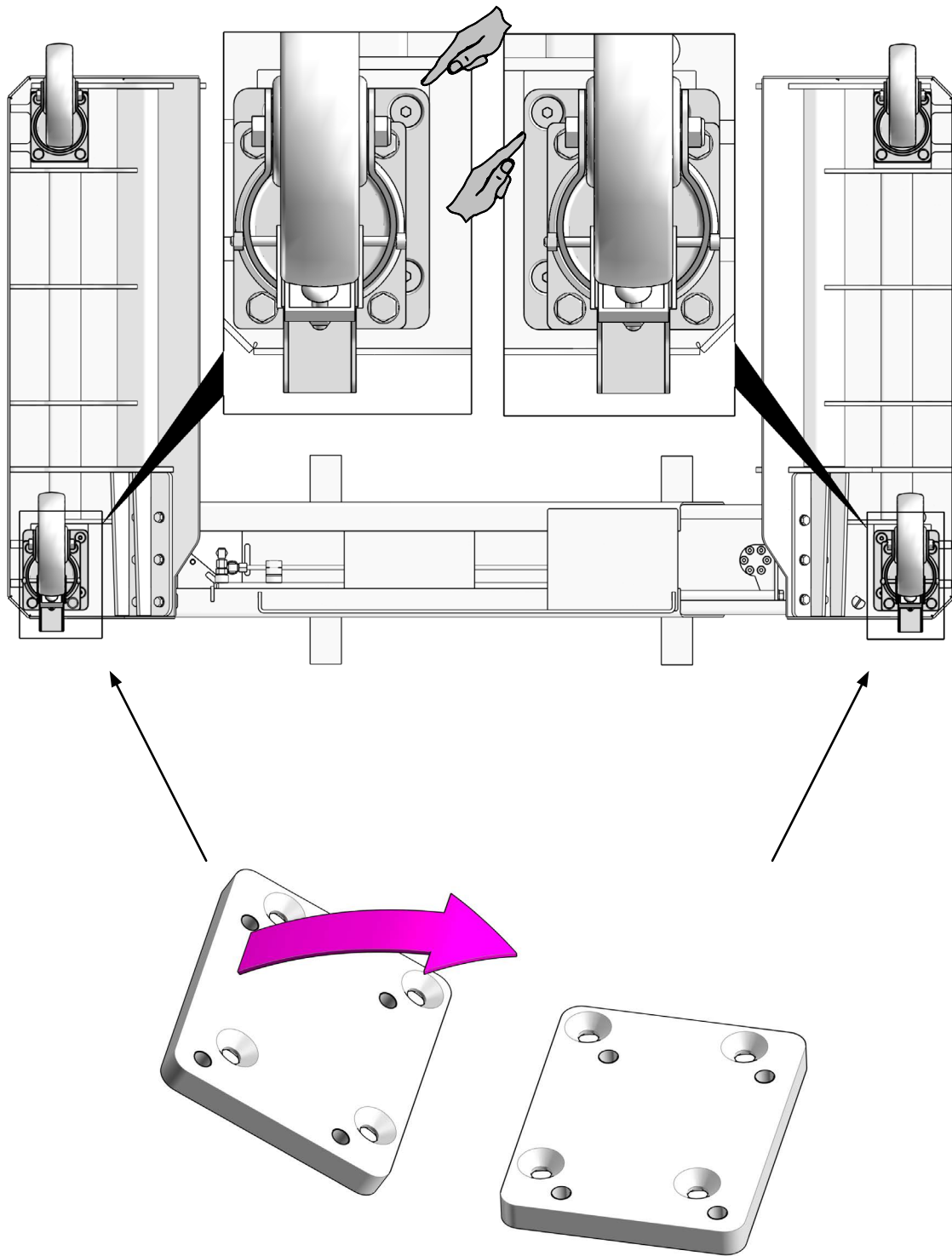

Fig.16
12

4

WT1500NT
WT1500NT-B

WT1500N → (Fig.18)

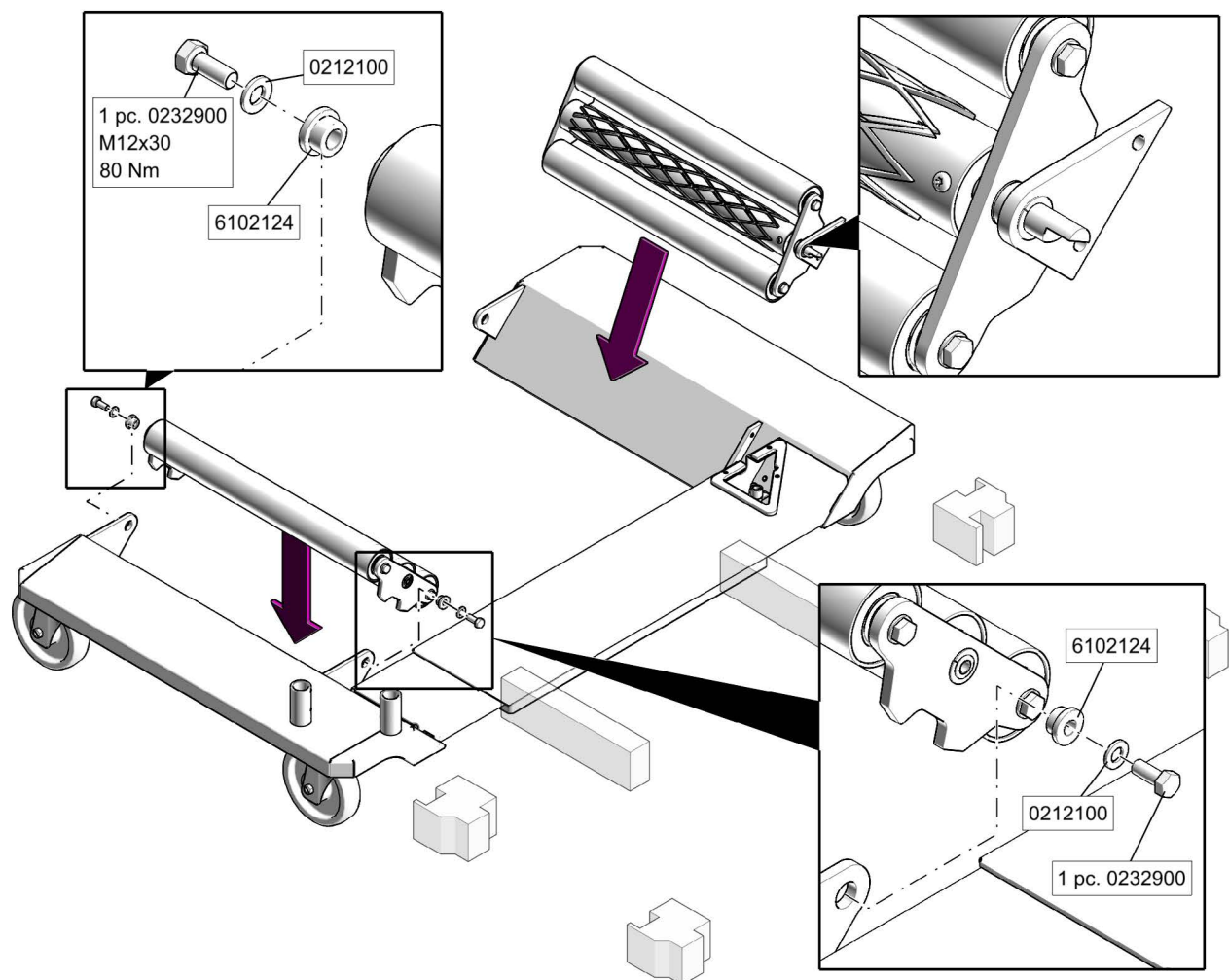
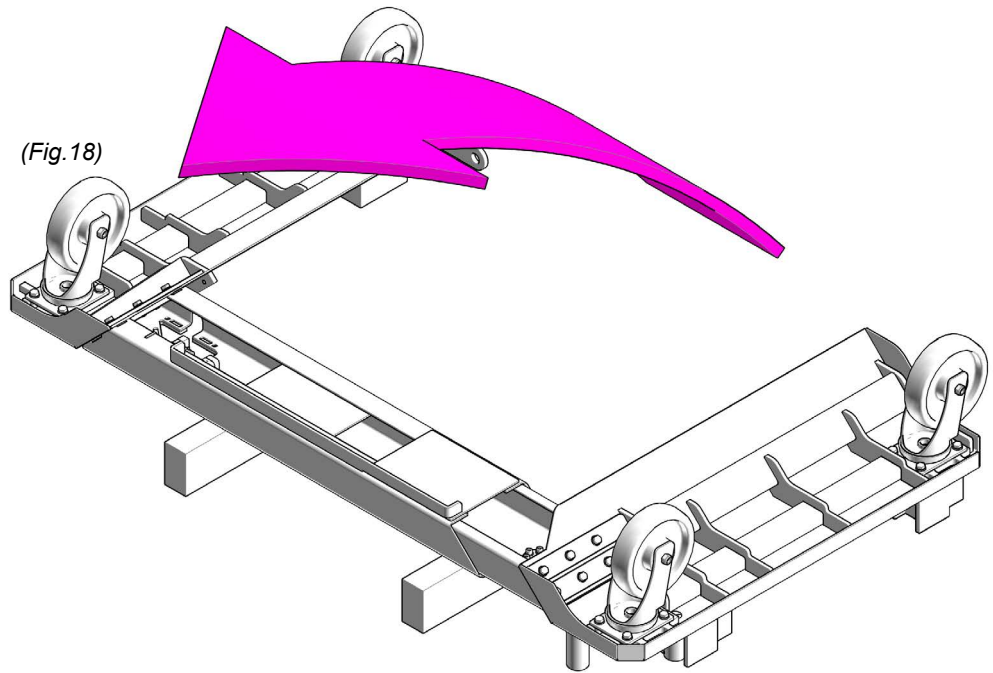

Fig.17

4

WT1500N

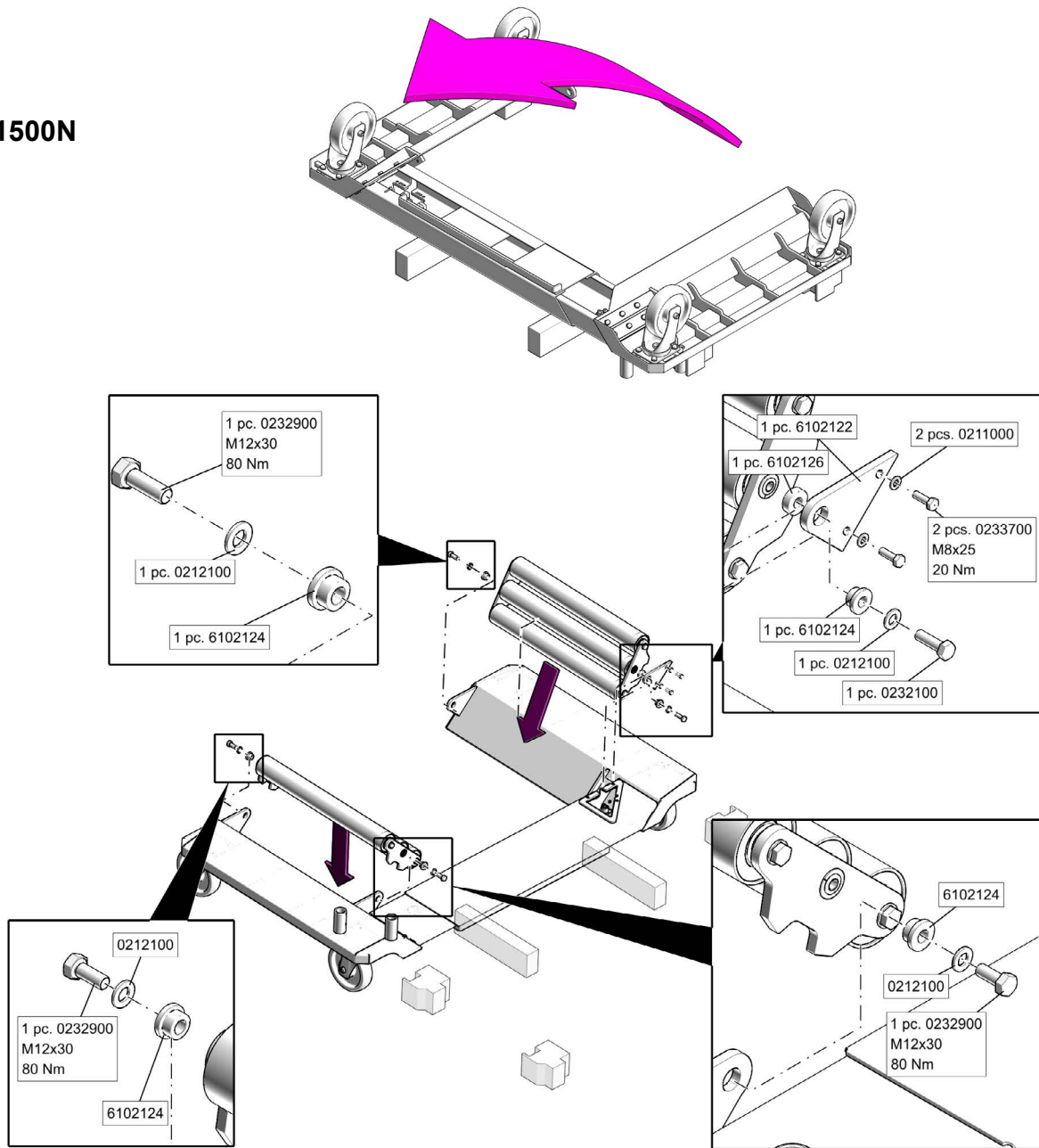

Fig.18

5

WT1500N

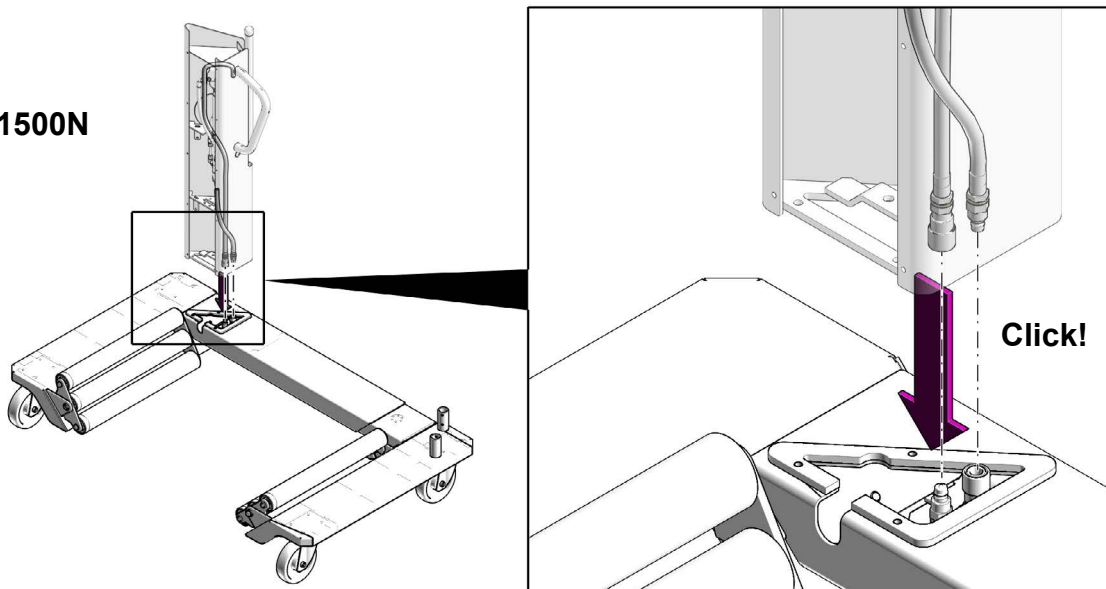

Fig.19

5

WT1500NT
WT1500NT-B

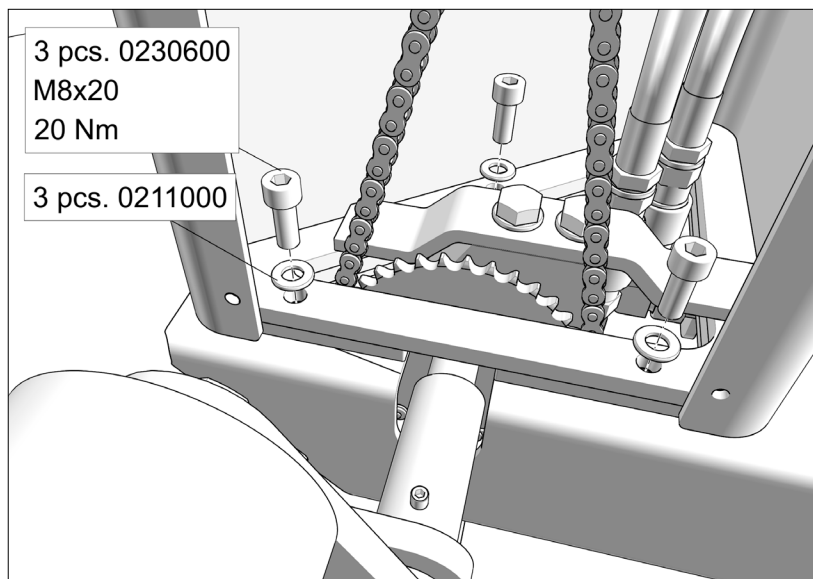
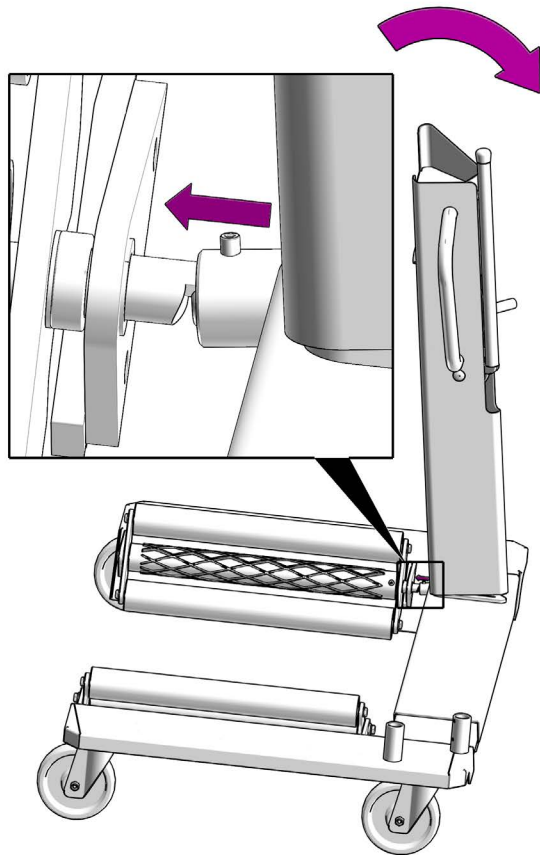
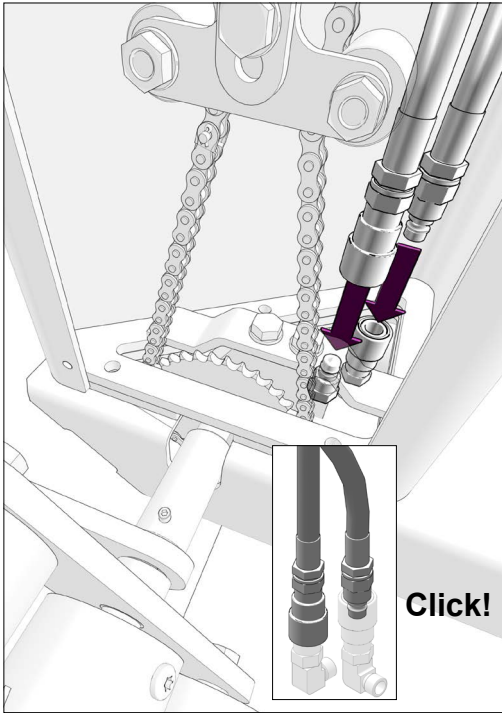
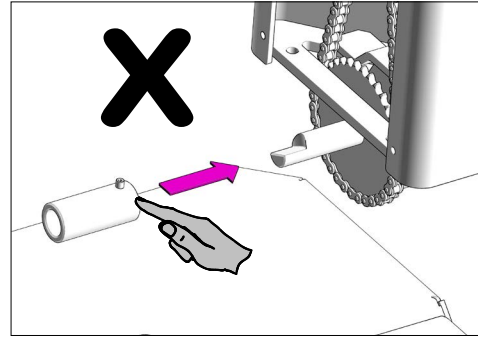
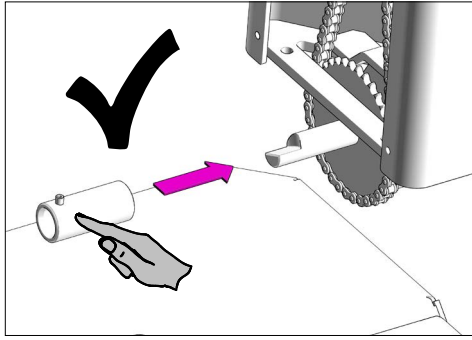

Fig.20

6

WT1500NT
WT1500NT-B

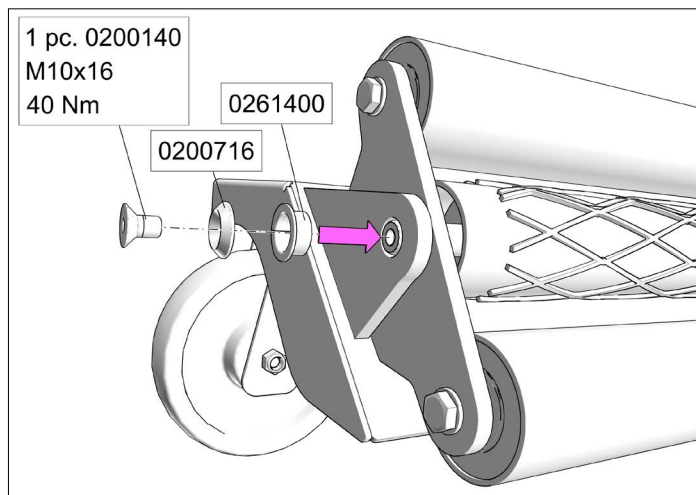
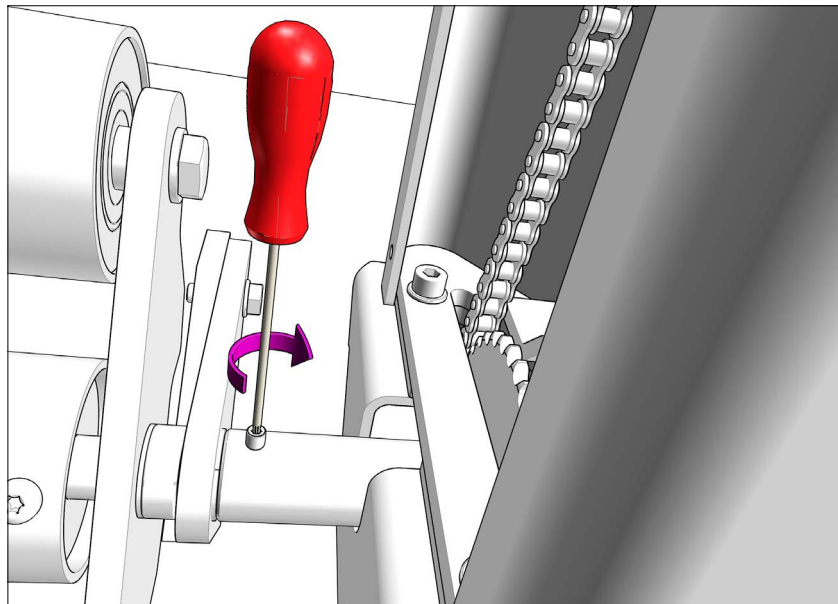
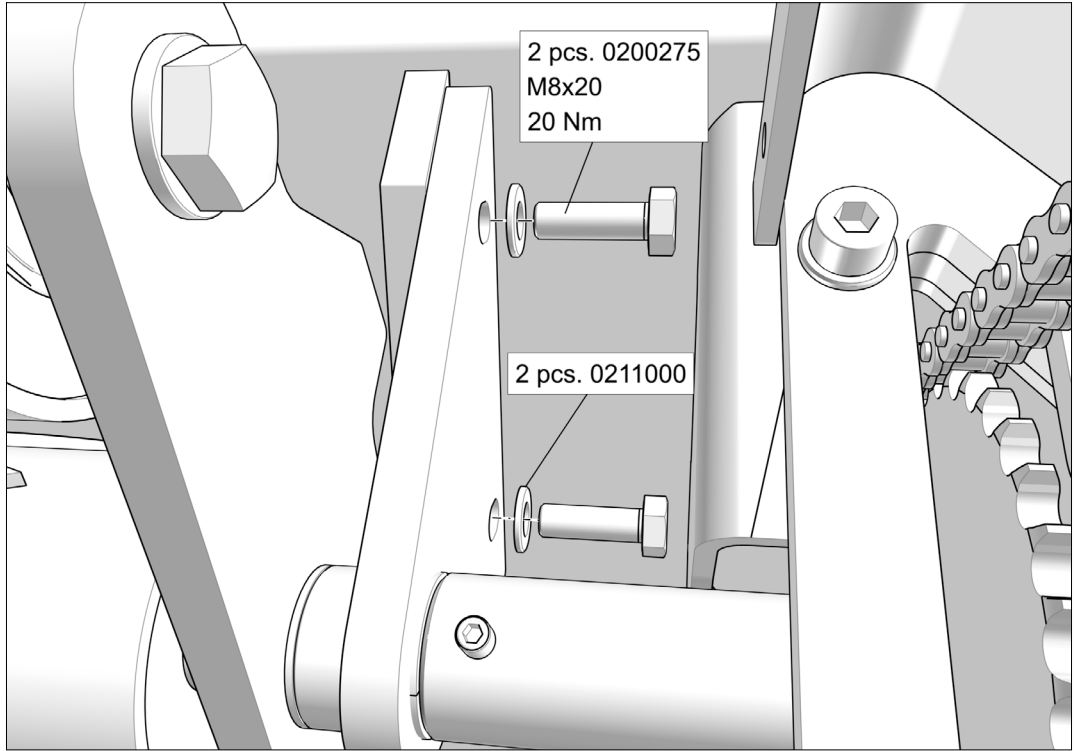

Fig.21
16

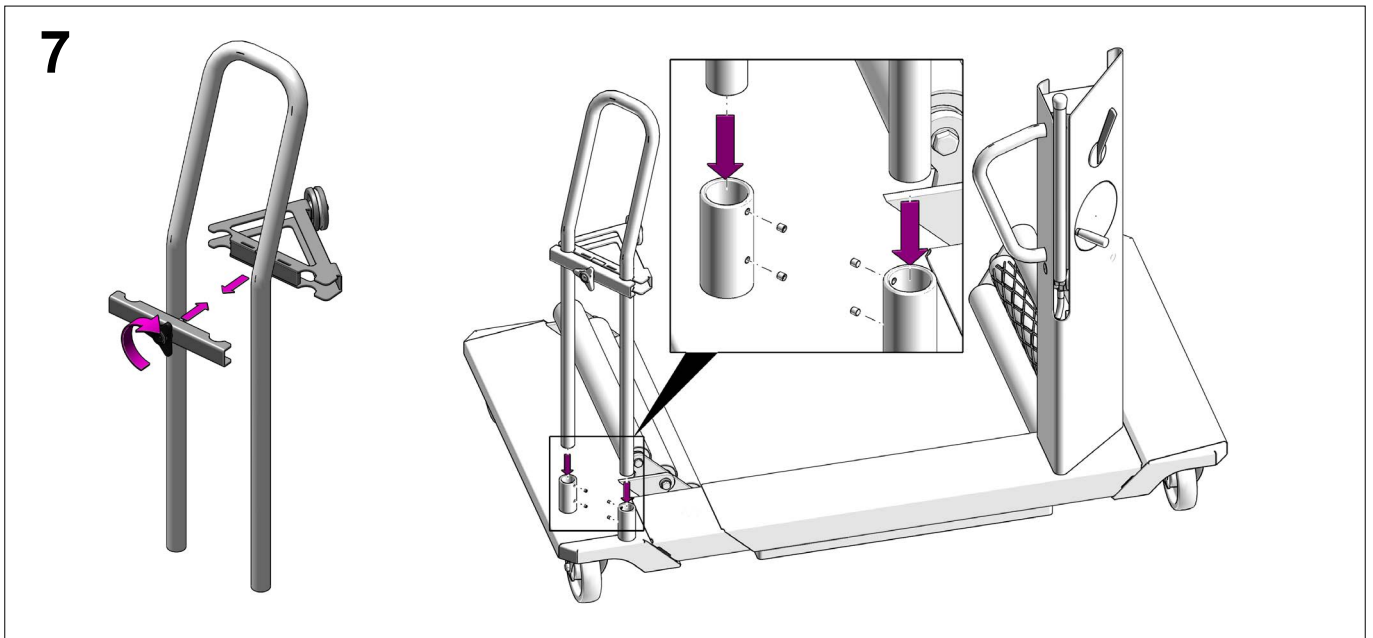

Fig.22

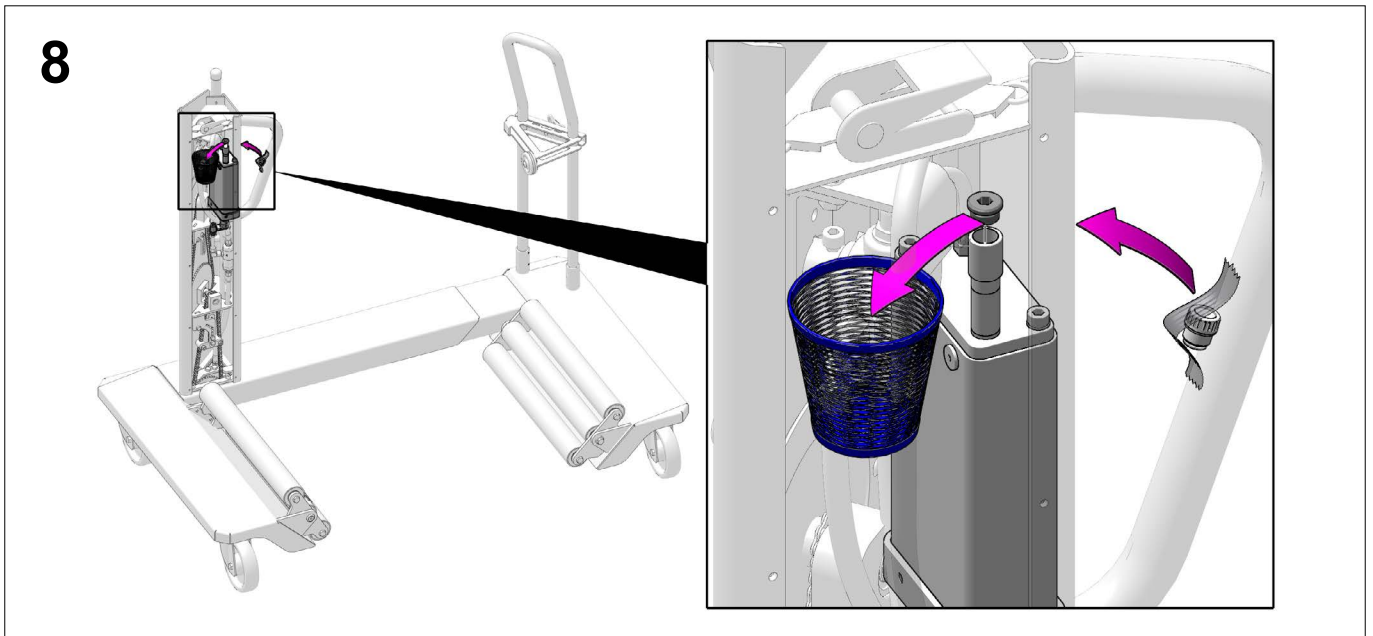

Fig.23

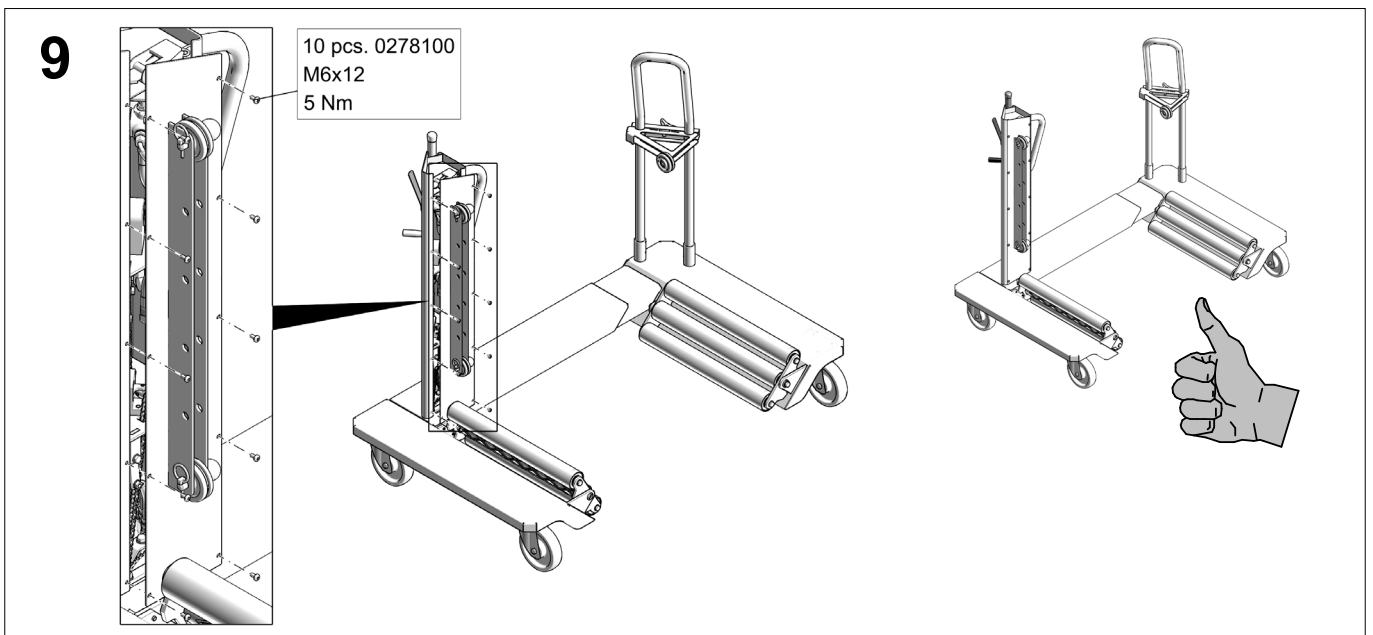
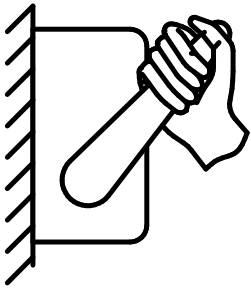

Fig.24



- ⓀⓃ ⓃⓄ **Betjening**
- ⒼⒷ **Use**
- ⒹⒺ **Bedienung**
- ⒻⓇ **Utilisation**
- ⓈⒺ **Användning**
- ⒻⒾ **Käyttäminen**
- ⓃⒻ **Gebruik**
- ⒺⓈ **Manejo**
- ⒾⓉ **Utilizzo**
- ⓇⓊ **Использование**

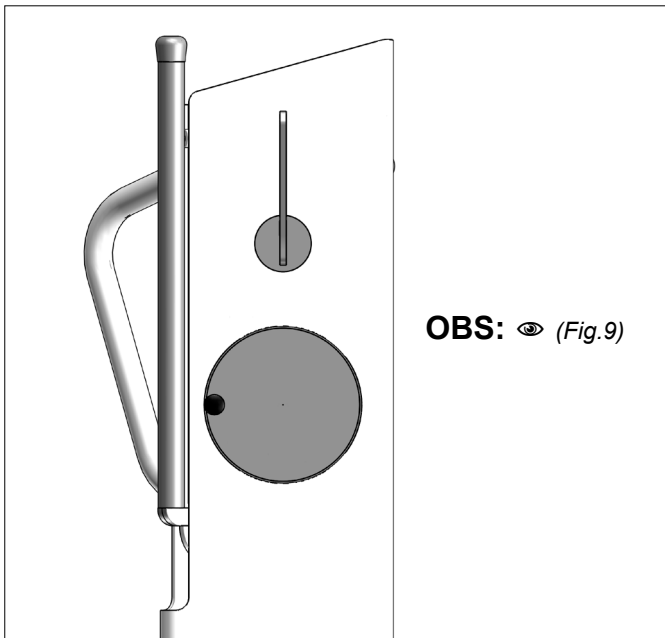

Fig.25

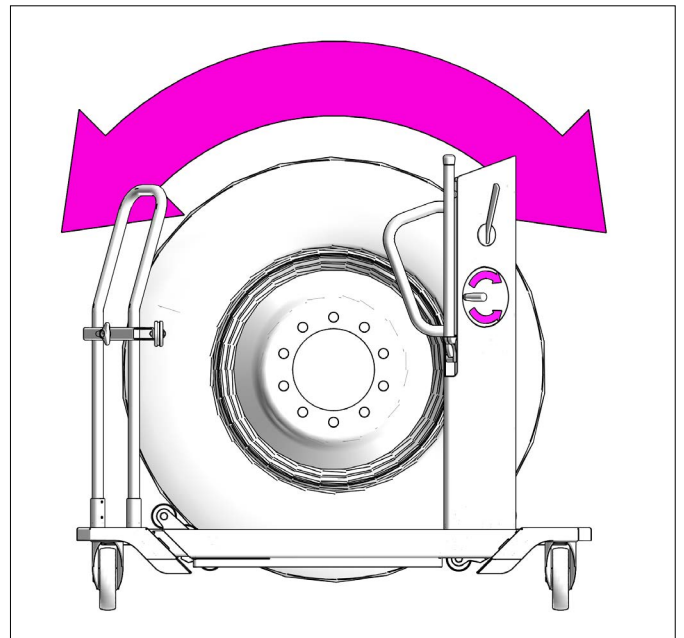

Fig.26

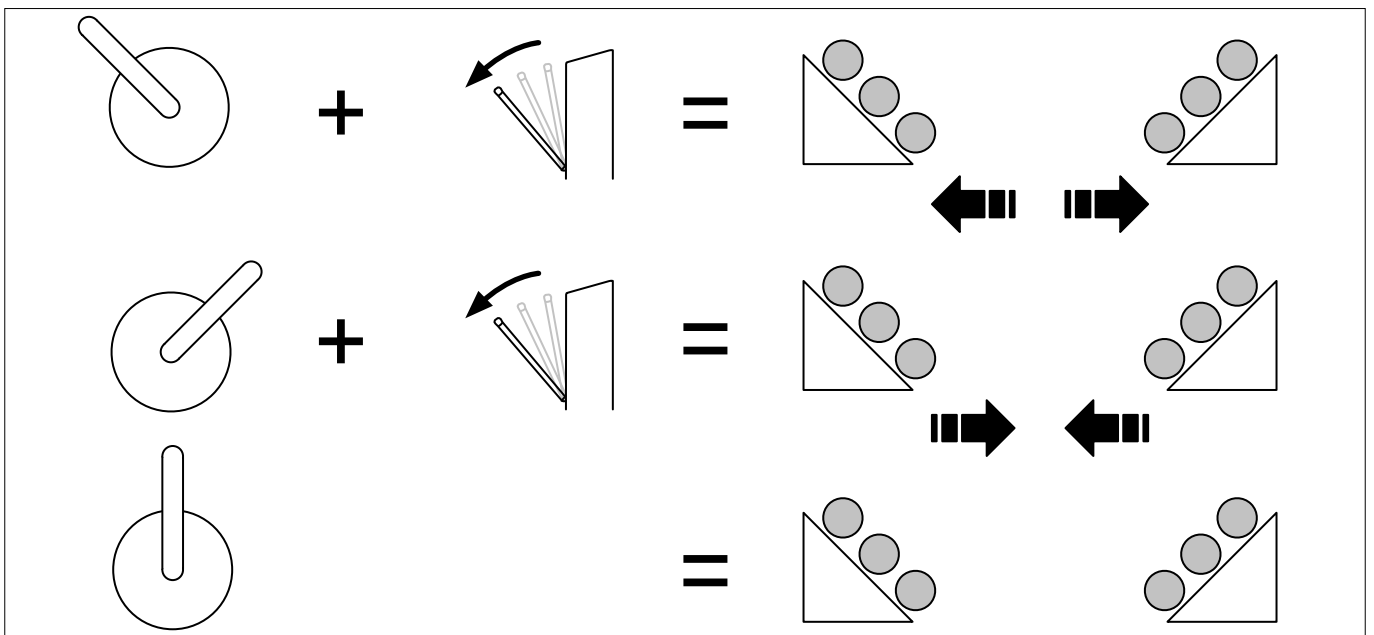
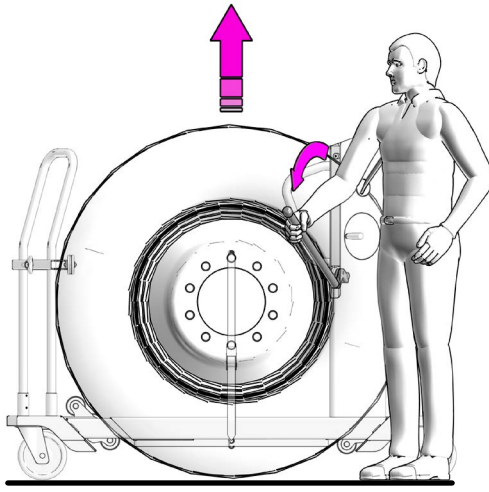
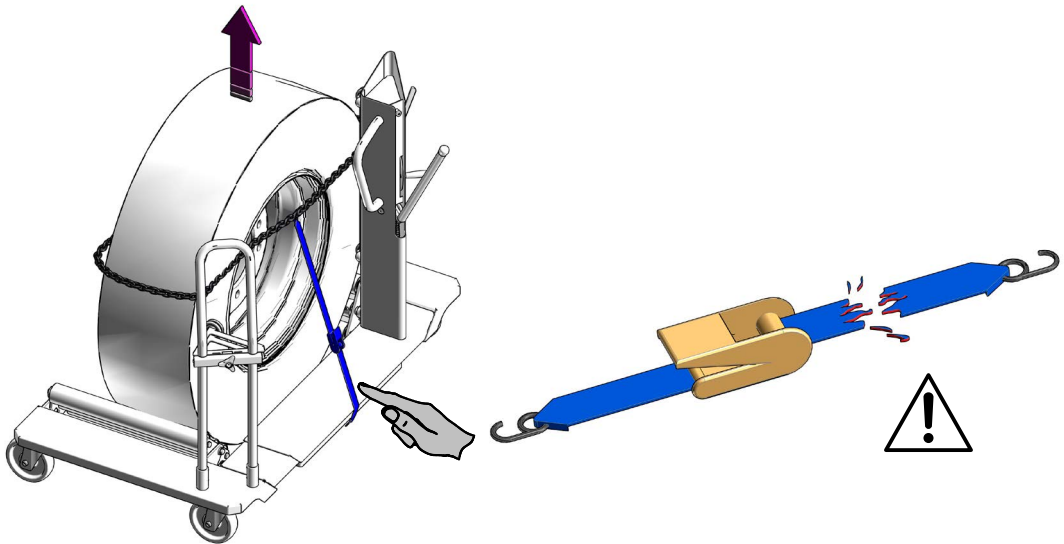

Fig.27



✘



✔

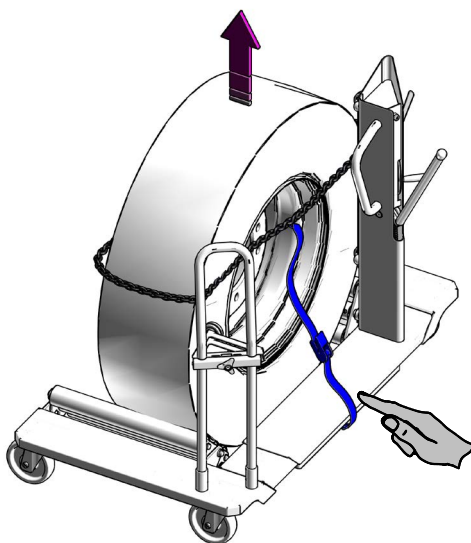
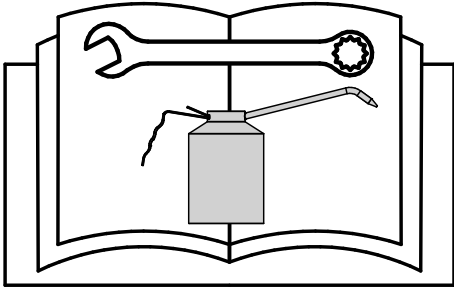

Fig.28



- ⓀⓃ NO Vedligeholdelse
- ⒼⒷ Users Maintenance
- ⒹⒺ Wartung
- ⒻⓇ Maintenance
- ⓈⒺ Underhåll
- ⒻⓂ Huolto
- ⓃⓁ Onderhoud
- ⒺⓈ Mantenimiento
- ⒾⓉ Manutenzione
- ⓇⓊ Техобслуживание

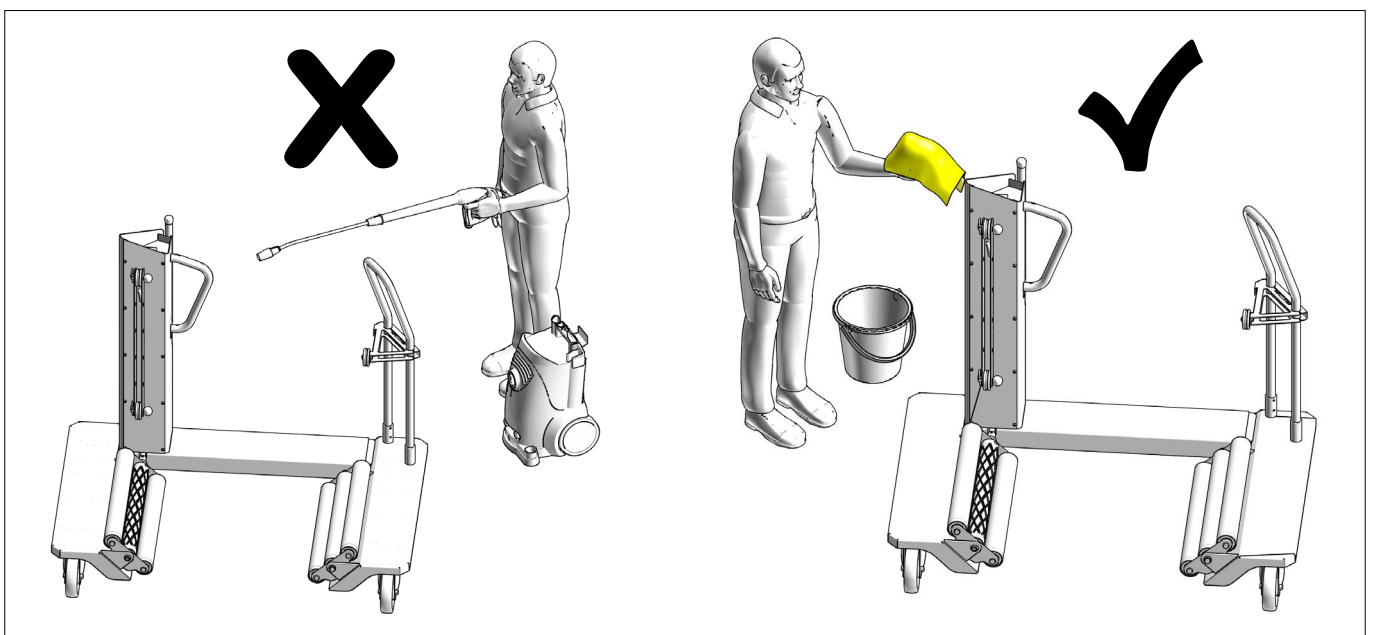
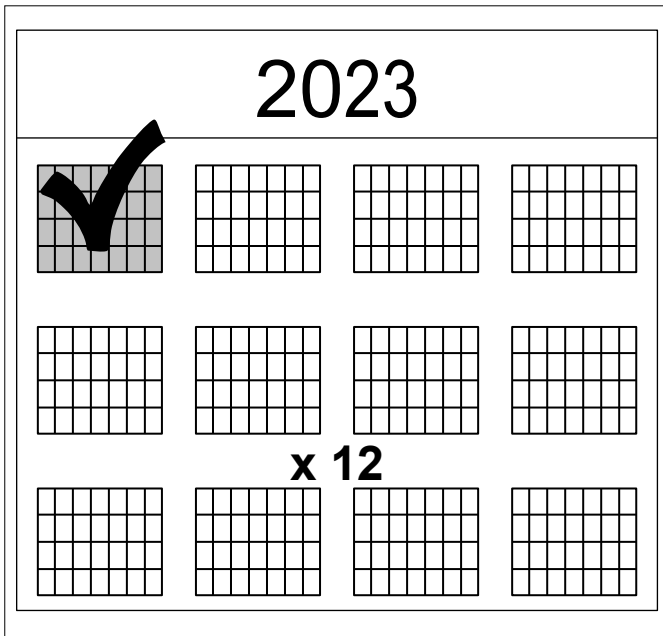

Fig. 29
20

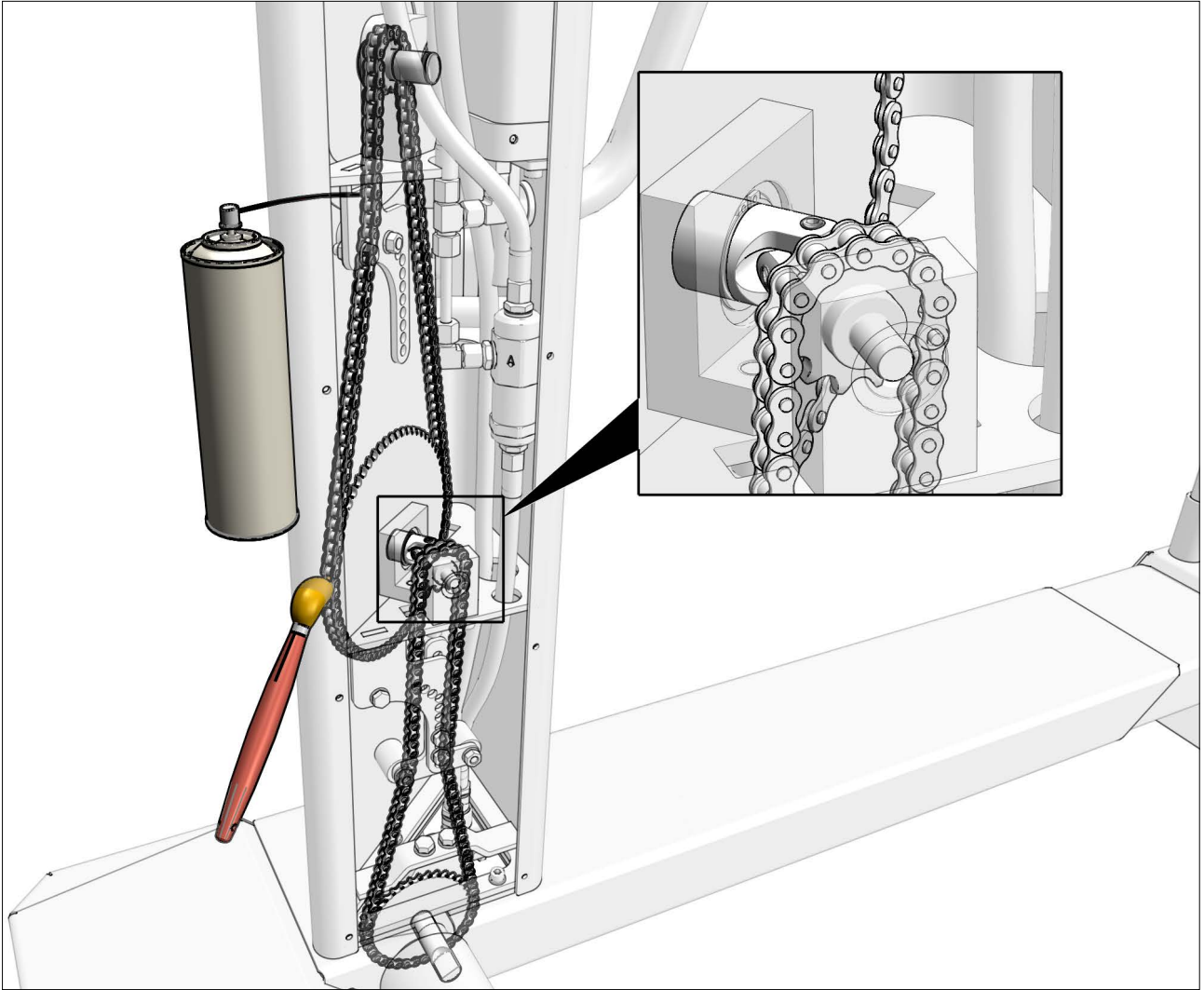

Fig.30

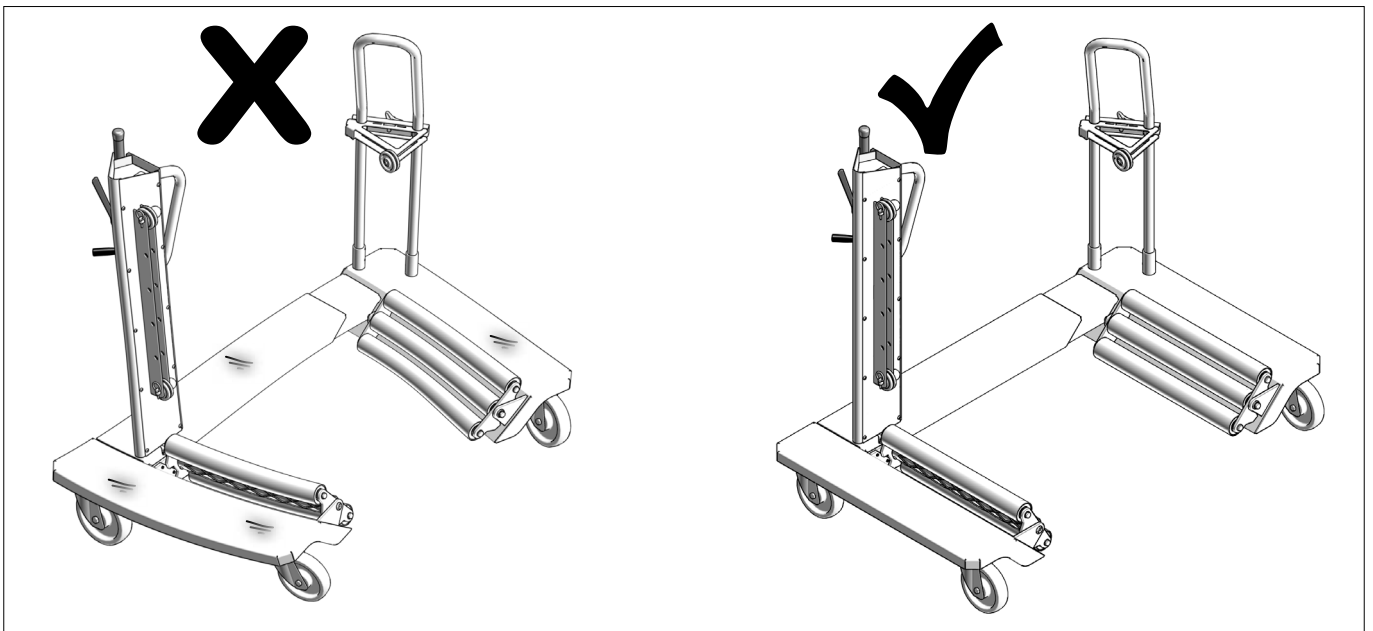

Fig.31

2023

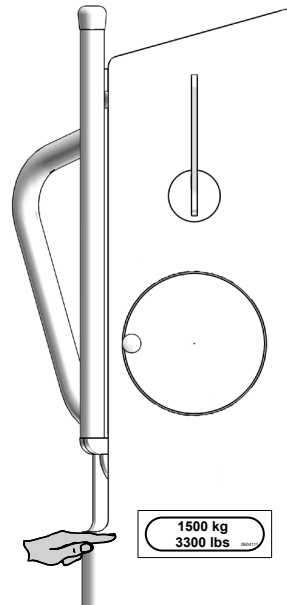
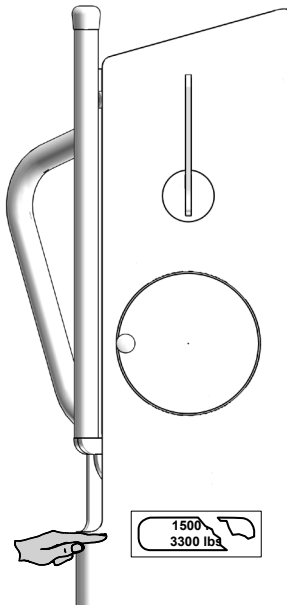
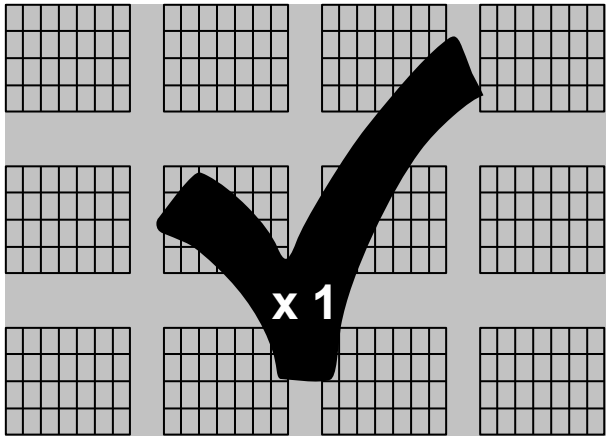
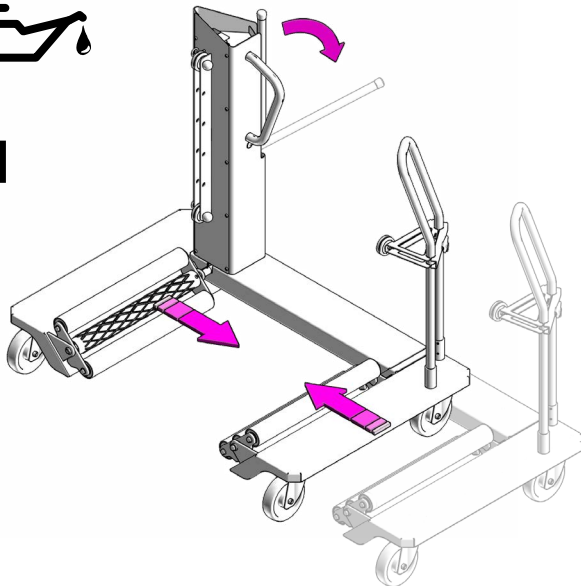

Fig.32



1



2

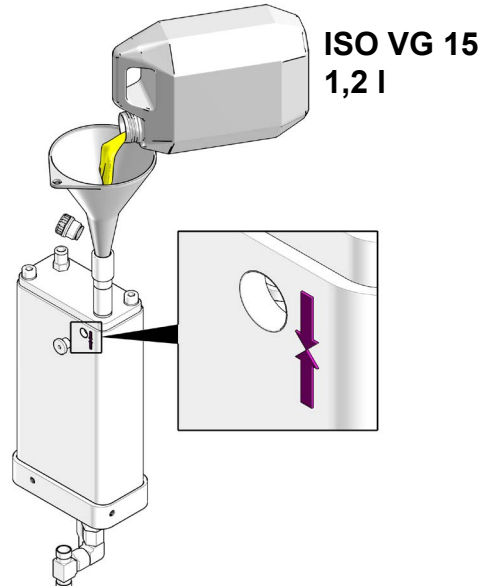
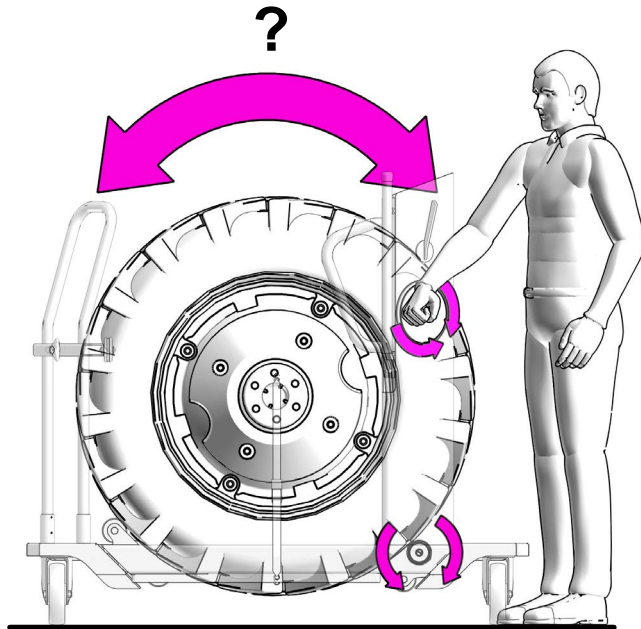

Fig.33



OBS:
 👁 **Fig.** (Fig.25) - (Fig.28)

?

?

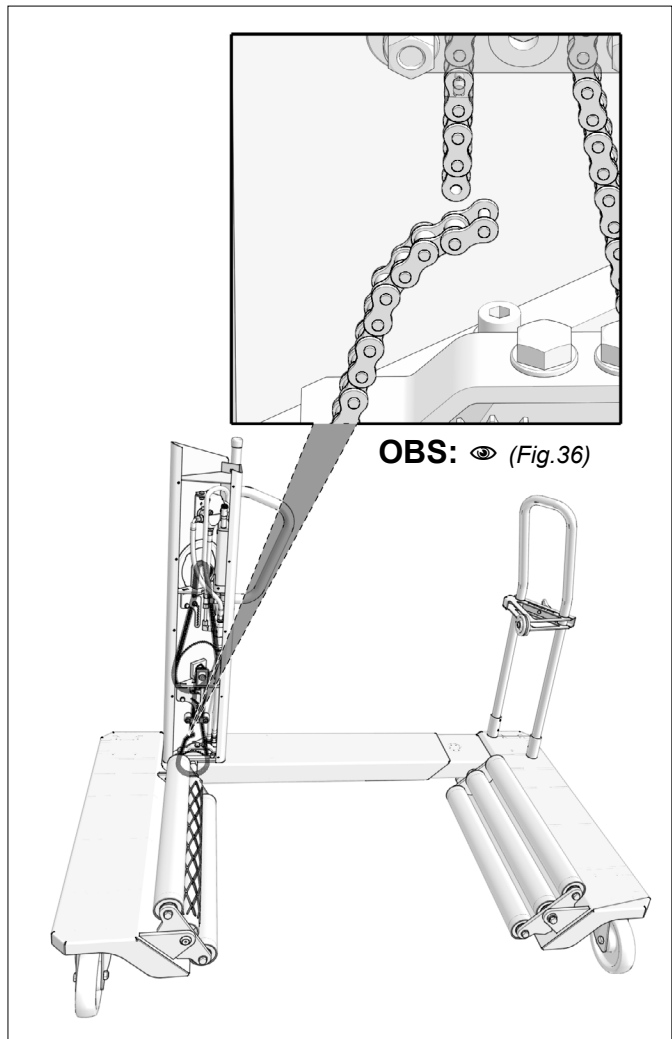
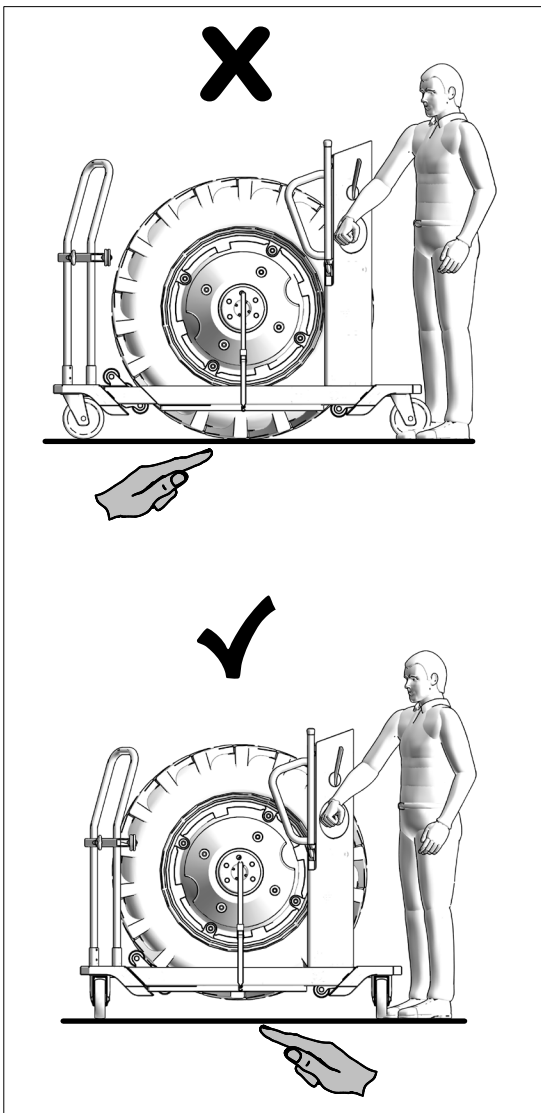

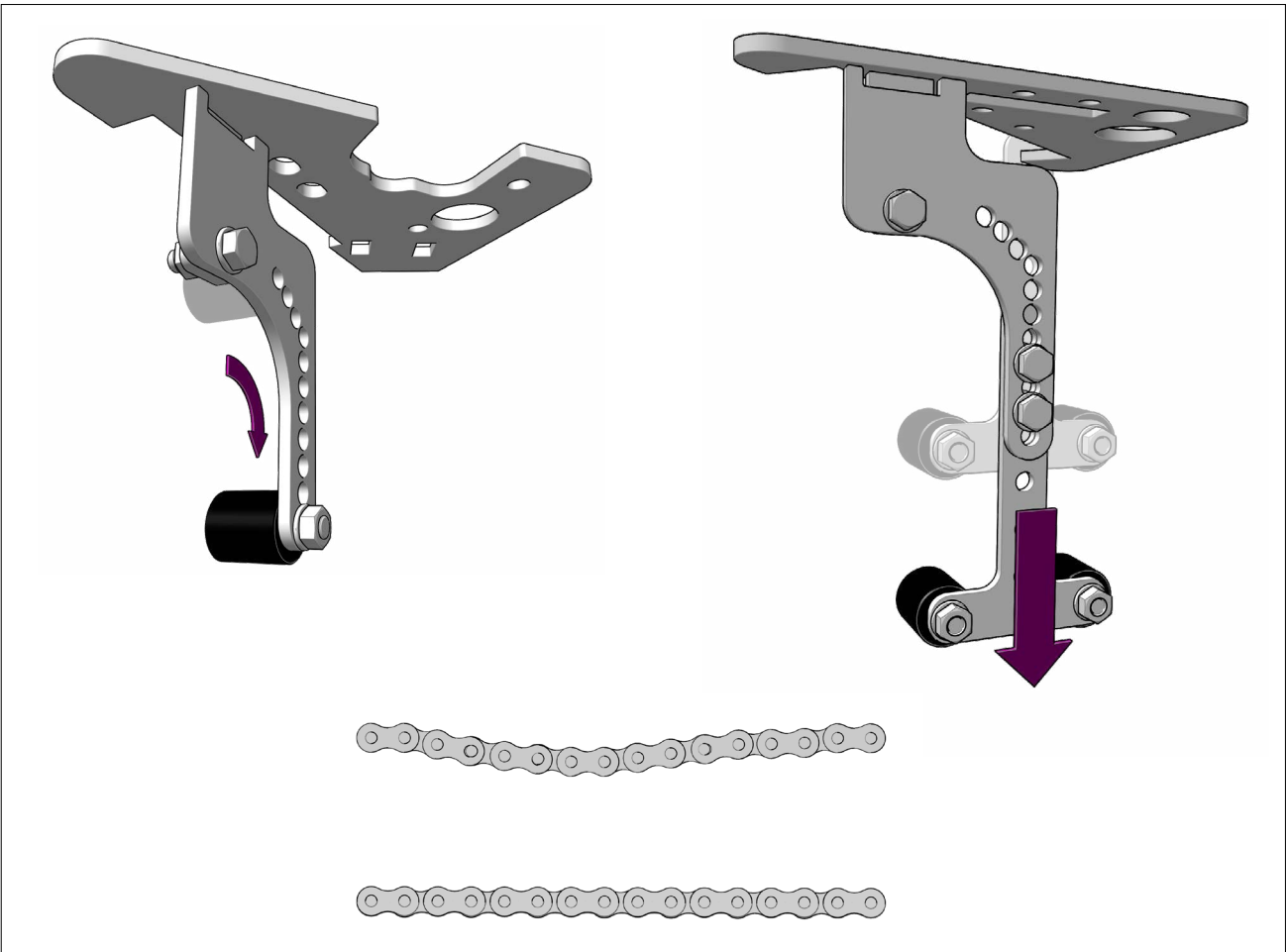
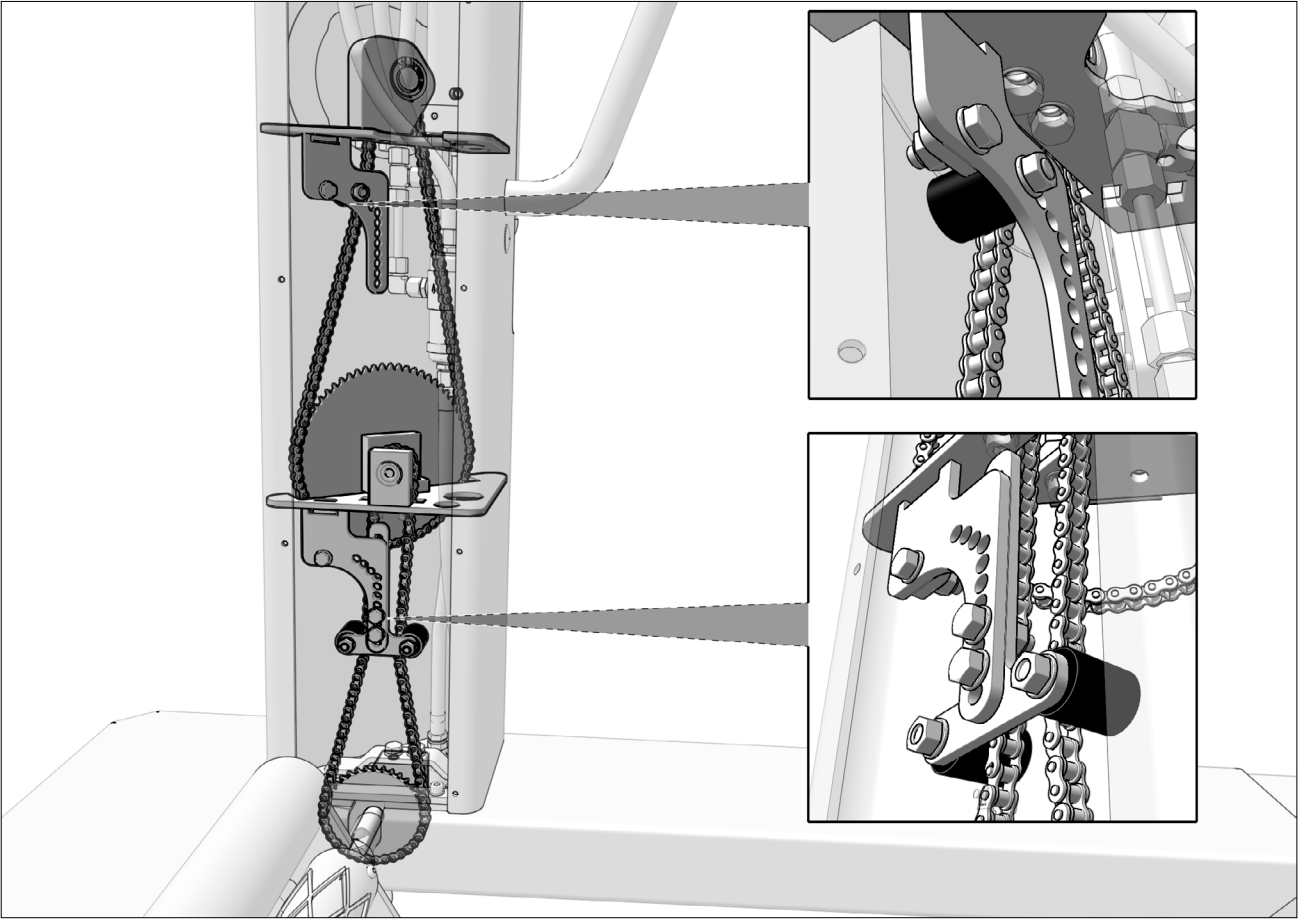
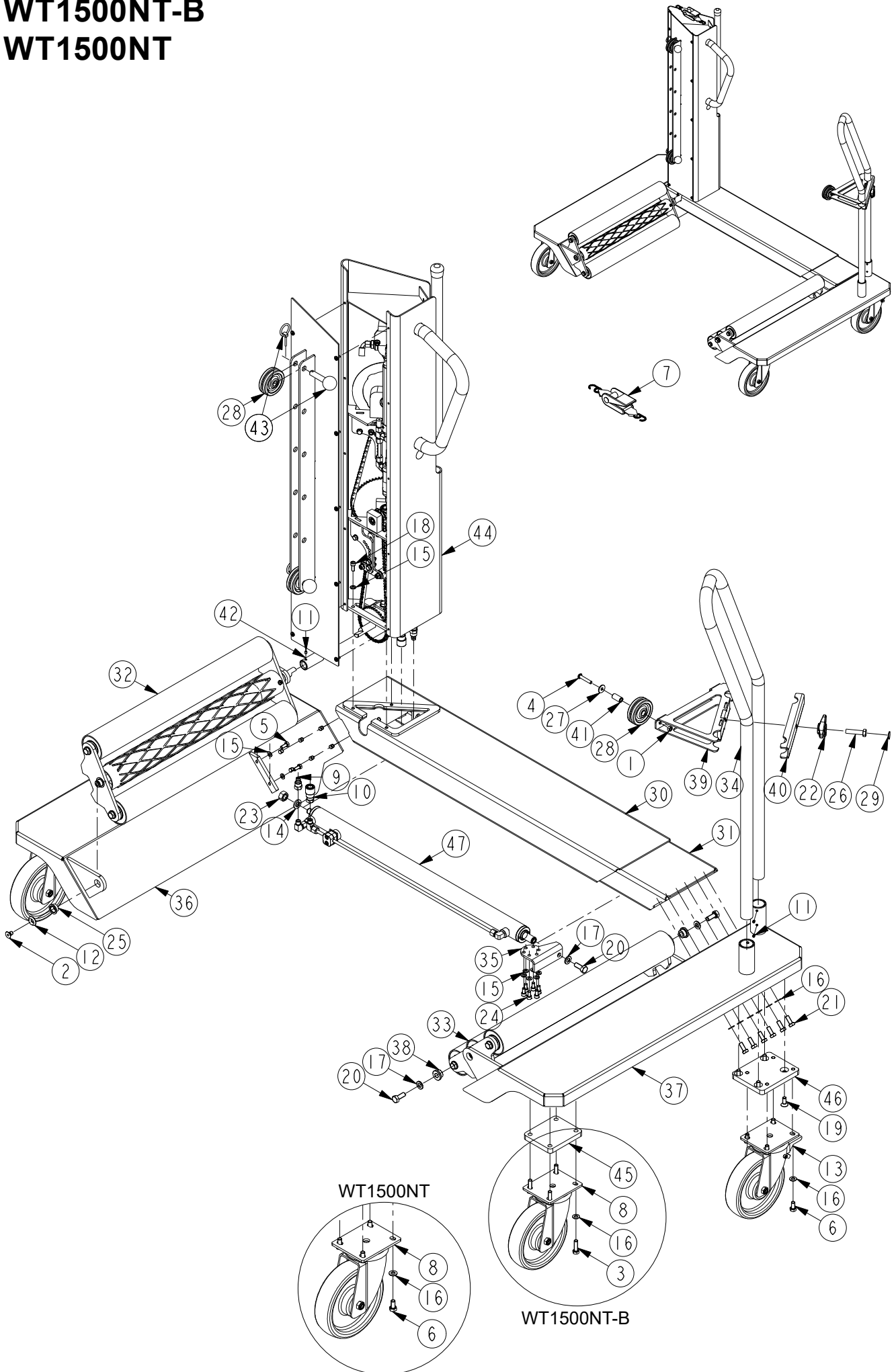

Fig. 36

WT1500NT-B WT1500NT



WT1500NT-B		WT1500NT	(DK)	(GB)	(DE)
Pos.	Art. No.	Art. No.	Pcs. Benævnelse	Description	Bezeichnung
	61 023 00	61 020 00	Hjulløfter	Wheel removal trolley	Radmontagegerät
1	02 001 00	02 001 00	1 Møtrik	Nut	Mutter
2	02 001 40	02 001 40	1 Skrue	Screw	Schraube
3	02 002 30		8 Skrue	Screw	Schraube
4	02 002 66	02 002 66	1 Skrue	Screw	Schraube
5	02 002 75	02 002 75	2 Skrue	Screw	Schraube
6	02 002 91	02 002 91	8/16 Skrue	Screw	Schraube
7	02 006 86	02 006 86	1 Surring	Ratchet tie	Ratschengurt
8	02 006 87	02 006 87	2/4 Hjul	Wheel	Rad
9	02 007 07	02 007 07	1 Fitting	Fitting	Fitting
10	02 007 08	02 007 08	1 Fitting	Fitting	Fitting
11	02 007 09	02 007 09	5 Pinolskrue	Pinol screw	Pinolschraube
12	02 007 16	02 007 16	1 Skive	Washer	Scheibe
13	02 007 36		2 Hjul	Wheel	Rad
14	02 106 00	02 106 00	1 Fjederskive	Spring washer	Federscheibe
15	02 110 00	02 110 00	11 Skive	Washer	Scheibe
16	02 116 00	02 116 00	28 Skive	Washer	Scheibe
17	02 121 00	02 121 00	3 Skive	Washer	Scheibe
18	02 306 00	02 306 00	3 Skrue	Screw	Schraube
19	02 312 00		8 Skrue	Screw	Schraube
20	02 329 00	02 329 00	3 Skrue	Screw	Schraube
21	02 334 00	02 334 00	12 Skrue	Screw	Schraube
22	02 452 00	02 452 00	1 Håndtag	Handle	Griff
23	02 460 00	02 460 00	1 Møtrik	Nut	Mutter
24	02 551 00	02 551 00	6 Skrue	Screw	Schraube
25	02 614 00	02 614 00	1 Leje	Bearing	Lager
26	02 668 00	02 668 00	1 Skrue	Screw	Schraube
27	02 766 00	02 766 00	1 Skive	Washer	Scheibe
28	36 008 00	36 008 00	3 Hjul	Wheel	Rad
29	44 109 01	44 109 01	1 Brik	Plug	Pfropfen
30	61 020 10	61 020 10	1 Vange, højre	Middleframe, right	Mittelrahmen, recht
31	61 020 20	61 020 20	1 Vange, venstre	Middleframe, left	Mittelrahmen, links
32	61 020 30	61 020 30	1 Ruller	Roller	Rollen
33	61 020 32	61 020 32	1 Ruller	Roller	Rollen
34	61 020 39	61 020 39	1 Håndtag	Handle	Hebel
35	61 020 96	61 020 96	1 Cylinderbeslag	Cylinder bracket	Zylinderbeslag
36	61 021 10	61 021 10	1 Hjulkonsol, højre	Wheelframe, right	Fahrrahmen, recht
37	61 021 20	61 021 20	1 Hjulkonsol, venstre	Wheelframe, left	Fahrrahmen, links
38	61 021 24	61 021 24	2 Bøsning	Bushing	Buchse
39	61 021 27	61 021 27	1 Støtte	Bracket	Beslag
40	61 021 33	61 021 33	1 Spændeåg	Bracket	Beslag
41	61 021 35	61 021 35	1 Afstandsør	Distance bushing	Abstandsbuschse
42	61 021 37	61 021 37	1 Bøsning	Bushing	Buchse
43	61 021 45	61 021 45	2 Håndbolt	Bolt	Boltzen
44	61 021 50	61 021 50	1 Søjle	Column	Säule
45	61 022 01		2 Adapterplade	Fitting plate	Montageplatte
46	61 022 02		2 Adapterplade	Fitting plate	Montageplatte
47	90 971 10	90 971 10	1 Cylinder	Cylinder	Zylinder

DK: De med * mærkede dele leveres i komplet paknings sæt. Anvend altid originale reservedele. Angiv venligst altid model og reservedels-nummer. Alle hoveddele kan ikke forventes leveret efter produktionsophør af model.

GB: * indicate parts included in repair set. Please always state model and part number. Do always apply original spare parts. All major parts may not be provided as spare parts after discontinuation of production of a model.

DE: Die mit * markierten Teile sind im Dichtungssatz enthalten. Bitte immer Modell und Ersatzteilnummer auf Ihren Bestellungen angeben. Immer nur Originalteile verwenden. Lieferung von allen Hauptteilen als Ersatzteile kann nach Produktions-Einstellung eines Modelles nicht erwartet werden.

WT1500N

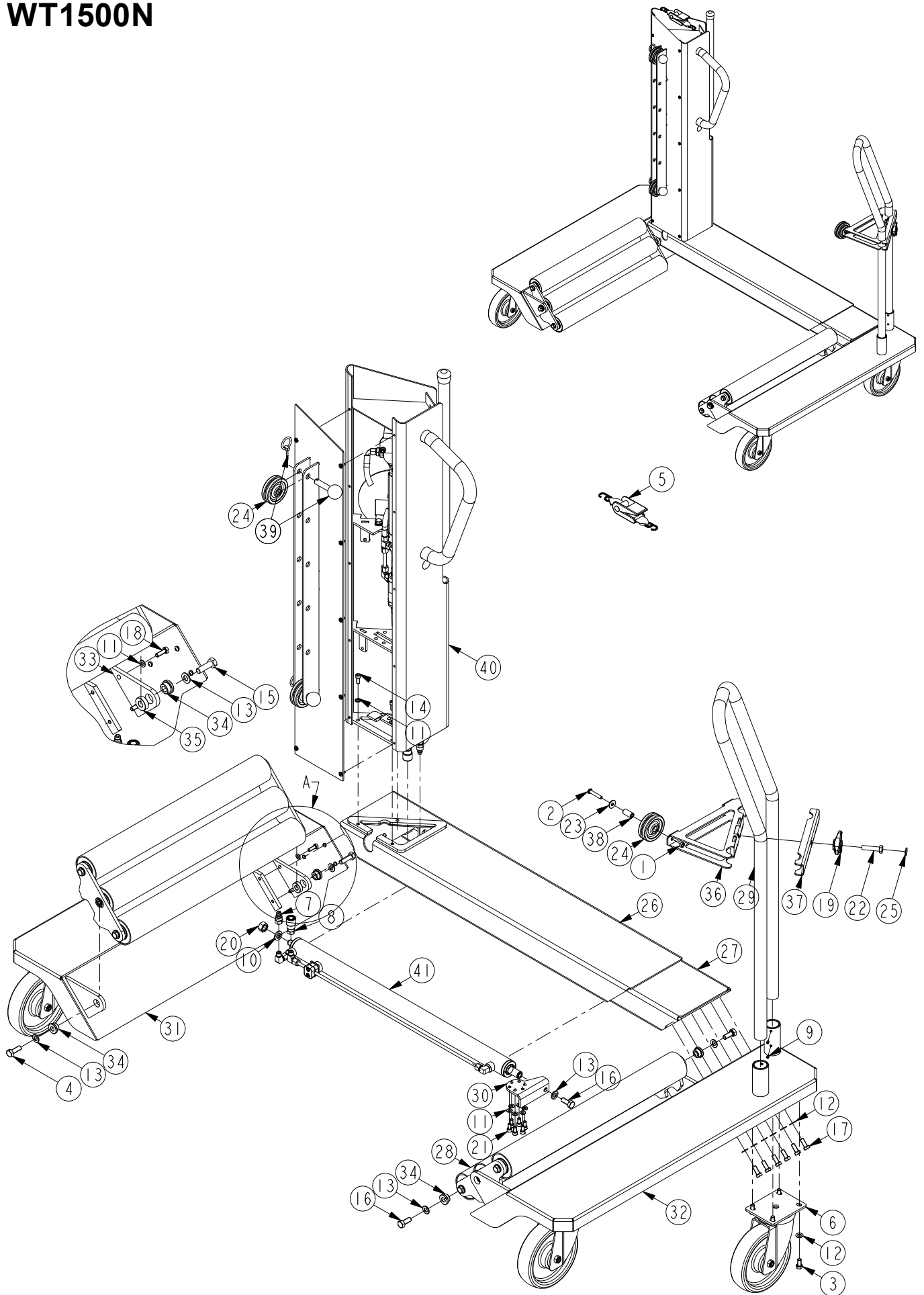

	WT1500N	(DK)	(GB)	(DE)
Pos.	Art. No.	Pcs. Benævnelse	Description	Bezeichnung
	61 021 00	Hjulløfter	Wheel removal trolley	Radmontagegerät
1	02 001 00	1 Møtrik	Nut	Mutter
2	02 002 66	1 Skrue	Screw	Schraube
3	02 002 91	16 Skrue	Screw	Schraube
4	02 005 06	1 Skrue	Screw	Schraube
5	02 006 86	1 Surring	Ratchet tie	Ratschengurt
6	02 006 87	4 Hjul	Wheel	Rad
7	02 007 07	1 Fitting	Fitting	Fitting
8	02 007 08	1 Fitting	Fitting	Fitting
9	02 007 09	4 Pinolskrue	Pinol screw	Pinolschraube
10	02 106 00	1 Fjederskive	Spring washer	Federscheibe
11	02 110 00	11 Skive	Washer	Scheibe
12	02 116 00	28 Skive	Washer	Scheibe
13	02 121 00	5 Skive	Washer	Scheibe
14	02 306 00	3 Skrue	Screw	Schraube
15	02 321 00	1 Skrue	Screw	Schraube
16	02 329 00	3 Skrue	Screw	Schraube
17	02 334 00	12 Skrue	Screw	Schraube
18	02 337 00	2 Skrue	Screw	Schraube
19	02 452 00	1 Håndtag	Handle	Griff
20	02 460 00	1 Møtrik	Nut	Mutter
21	02 551 00	6 Skrue	Screw	Schraube
22	02 668 00	1 Skrue	Screw	Schraube
23	02 766 00	1 Skive	Washer	Scheibe
24	36 008 00	3 Hjul	Wheel	Rad
25	44 109 01	1 Brik	Plug	Pfropfen
26	61 020 10	1 Vange, højre	Middleframe, right	Mittelrahmen, recht
27	61 020 20	1 Vange, venstre	Middleframe, left	Mittelrahmen, links
28	61 020 32	2 Ruller	Roller	Rollen
29	61 020 39	1 Håndtag	Handle	Hebel
30	61 020 96	1 Cylinderbeslag	Cylinder bracket	Zylinderbeschlag
31	61 021 10	1 Hjulkonsol, højre	Wheelframe, right	Fahrrahmen, recht
32	61 021 20	1 Hjulkonsol, venstre	Wheelframe, left	Fahrrahmen, links
33	61 021 22	1 Rullekonsol	Roller bracket	Rollen beschlag
34	61 021 24	4 Bøsning	Bushing	Buchse
35	61 021 26	1 Skive	Washer	Scheibe
36	61 021 27	1 Støtte	Bracket	Beschlag
37	61 021 33	1 Spændeåg	Bracket	Beschlag
38	61 021 35	1 Afstandsrør	Distance bushing	Abstandsbuchse
39	61 021 45	2 Håndbolt	Bolt	Boltzen
40	61 021 60	1 Søjle	Column	Säule
41	90 971 10	1 Cylinder	Cylinder	Zylinder

DK: De med * mærkede dele leveres i komplet pakningssæt. Anvend altid originale reservedele. Angiv venligst altid model og reservedels-nummer. Alle hoveddele kan ikke forventes leveret efter produktionsophør af model.

GB: * indicate parts included in repair set. Please always state model and part number. Do always apply original spare parts.

DE: All major parts may not be provided as spare parts after discontinuation of production of a model.

DE: Die mit * markierten Teile sind im Dichtungssatz enthalten. Bitte immer Modell und Ersatzteilnummer auf Ihren Bestellungen angeben. Immer nur Originalteile verwenden. Lieferung von allen Hauptteilen als Ersatzteile kann nach Produktions-Einstellung eines Modelles nicht erwartet werden.

61 021 50

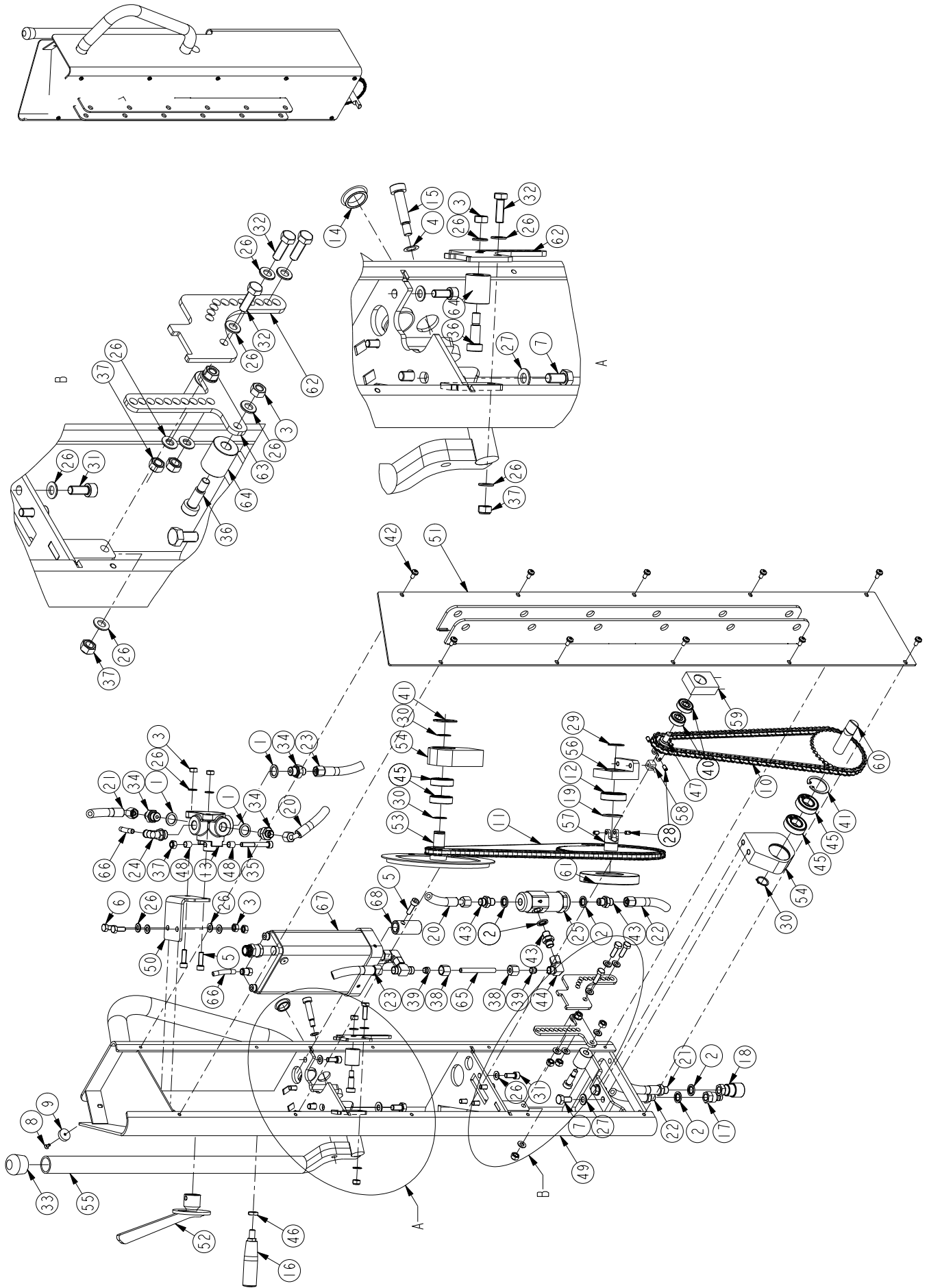

WT1500NT-B WT1500NT		(DK)	(GB)	(DE)
Pos.	Art. No.	Pcs. Benævnelse	Description	Bezeichnung
	61 021 50	Søjle	Column	Säule
1	01 244 00	3 Pakning	Seal	Dichtung
2	01 438 00	5 Pakning	Seal	Dichtung
3	02 001 00	7 Møtrik	Nut	Mutter
4	02 001 28	1 Skive	Washer	Scheibe
5	02 001 74	3 Skrue	Screw	Schraube
6	02 002 75	2 Skrue	Screw	Schraube
7	02 002 91	4 Skrue	Screw	Schraube
8	02 003 40	1 Skrue	Screw	Schraube
9	02 006 23	1 Magnet	Magnet	Magnet
10	02 006 88	1 Kæde	Chain	Ketten
11	02 006 89	1 Kæde	Chain	Ketten
12	02 006 92	1 Leje	Bearing	Lager
13	02 006 93	1 Ventil	Valve	Ventil
14	02 006 95	1 Prop	Plug	Pfropfen
15	02 006 96	1 Pasbolt	Screw	Schraube
16	02 006 97	1 Håndtag	Handle	Griff
17	02 007 07	1 Fitting	Fitting	Fitting
18	02 007 08	1 Fitting	Fitting	Fitting
19	02 007 15	1 Skive	Washer	Scheibe
20	02 007 19	1 Hydraulikslange	Hydraulic hose	Hydraulikschlauch
21	02 007 20	1 Hydraulikslange	Hydraulic hose	Hydraulikschlauch
22	02 007 21	1 Hydraulikslange	Hydraulic hose	Hydraulikschlauch
23	02 007 26	1 Hydraulikslange	Hydraulic hose	Hydraulikschlauch
24	02 008 64	1 Fitting	Fitting	Fitting
25	02 008 68	1 Ventil	Valve	Ventil
26	02 110 00	23 Skive	Washer	Scheibe
27	02 116 00	4 Skive	Washer	Scheibe
28	02 145 00	4 Pinolskrue	Pinol screw	Pinolschraube
29	02 206 00	1 Seegerring	Seegerring	Seegerring
30	02 222 00	3 Seegerring	Seegerring	Seegerring
31	02 306 00	6 Skrue	Screw	Schraube
32	02 337 00	4 Skrue	Screw	Schraube
33	02 369 00	1 Prop	Plug	Pfropfen
34	02 455 00	3 Fitting	Fitting	Fitting
35	02 535 00	1 Skrue	Screw	Schraube
36	02 540 00	3 Pasbolt	Screw	Schraube
37	02 550 00	5 Møtrik	Nut	Mutter
38	02 656 00	2 Omløber	Union nut	Überwurfmutter
39	02 657 00	2 Skærring	Ring	Sneidring
40	02 710 00	2 Leje	Bearing	Lager
41	02 748 00	2 Låsering	Locking ring	Schliessring
42	02 781 00	10 Skrue	Screw	Schraube
43	02 821 00	3 Fitting	Fitting	Fitting
44	02 863 00	1 Fitting	Fitting	Fitting
45	02 978 00	4 Leje	Bearing	Lager
46	02 984 00	1 Møtrik	Nut	Mutter
47	61 020 17	1 Tandhjul	Chainwheel	Kettenrad
48	61 020 19	2 Bøsning	Bushing	Buchse
49	61 020 40	1 Søjle	Column	Säule
50	61 020 52	1 Ventilbeslag	Valve bracket	Ventil Beschlag
51	61 020 60	1 Bagplade	Cover	Abdeckblech
52	61 020 63	1 Greb for ventil	Valve handle	Ventil griff
53	61 020 67	1 Håndhjul	Wheel disc	Radscheibe
54	61 020 72	2 Lejeplade	Bearing disc	Lagerscheibe
55	61 020 74	1 Pumpehåndtag	Pump handle	Pumpehebel
56	61 020 78	1 Lejeholder	Bearing housing	Lagergehäuse
57	61 020 79	1 Tandhjul	Chainwheel	Kettenrad
58	61 020 83	1 Kardan kryds	Cardan Shaft	Kardan
59	61 020 87	1 Lejebuk	Bearing housing	Lagergehäuse
60	61 020 88	1 Tandhjul	Chainwheel	Kettenrad
61	61 021 23	1 Kædehjulsstøtte	Support disc	Stützplatte
62	61 021 47	2 Kædestrammer	Chain tensioner	Kettenspanner
63	61 021 48	1 Kædestrammer 2	Chain tensioner 2	Kettenspanner 2
64	63 019 00	3 Rulle	Roller	Rollen
65	70 012 40	1 Hydraulikrør	Hydraulic tube	Hydraulik Rohr
66	90 798 12	1 Luftslange	Air hose	Luftschlauch
67	90 971 00	1 Pumpe	Pump	Pump
68	90 971 06	1 Tryksko	Press head	Druckschuhe

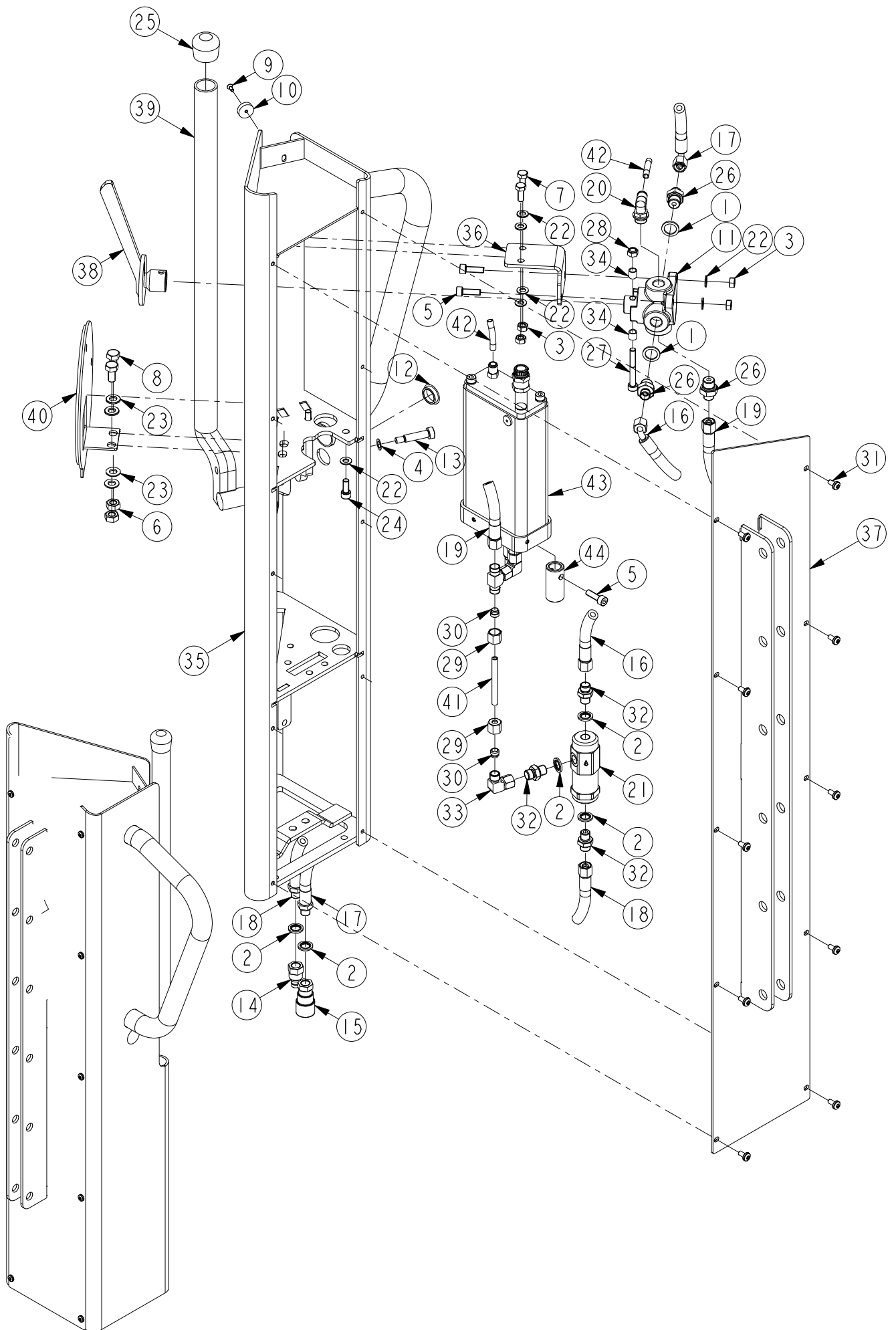

WT1500N		(DK)	(GB)	(DE)
Pos.	Art. No.	Pcs. Benævnelse	Description	Bezeichnung
	61 021 60	Søjle	Column	Säule
1	01 244 00	3 Pakning	Seal	Dichtung
2	01 438 00	5 Pakning	Seal	Dichtung
3	02 001 00	4 Møtrik	Nut	Mutter
4	02 001 28	1 Passkive	Washer	Scheibe
5	02 001 74	3 Skrue	Screw	Schraube
6	02 002 00	2 Møtrik	Nut	Mutter
7	02 002 75	2 Skrue	Screw	Schraube
8	02 002 91	2 Skrue	Screw	Schraube
9	02 003 40	1 Skrue	Screw	Schraube
10	02 006 23	1 Magnet	Magnet	Magnet
11	02 006 93	1 Ventil	Valve	Ventil
12	02 006 95	1 Prop	Plug	Pfropfen
13	02 006 96	1 Pasbolt	Screw	Schraube
14	02 007 07	1 Fitting	Fitting	Fitting
15	02 007 08	1 Fitting	Fitting	Fitting
16	02 007 19	1 Hydraulikslange	Hydraulic hose	Hydraulikschlauch
17	02 007 20	1 Hydraulikslange	Hydraulic hose	Hydraulikschlauch
18	02 007 21	1 Hydraulikslange	Hydraulic hose	Hydraulikschlauch
19	02 007 26	1 Hydraulikslange	Hydraulic hose	Hydraulikschlauch
20	02 008 64	1 Fitting	Fitting	Fitting
21	02 008 68	1 Ventil	Valve	Ventil
22	02 110 00	8 Skive	Washer	Scheibe
23	02 116 00	4 Skive	Washer	Scheibe
24	02 306 00	2 Skrue	Screw	Schraube
25	02 369 00	1 Prop	Plug	Pfropfen
26	02 455 00	3 Fitting	Fitting	Fitting
27	02 535 00	1 Skrue	Screw	Schraube
28	02 550 00	1 Møtrik	Nut	Mutter
29	02 656 00	2 Omløber	Union nut	Überwurfmutter
30	02 657 00	2 Skærring	Ring	Sneidring
31	02 781 00	10 Skrue	Screw	Schraube
32	02 821 00	3 Fitting	Fitting	Fitting
33	02 863 00	1 Fitting	Fitting	Fitting
34	61 020 19	2 Bøsning	Bushing	Buchse
35	61 020 40	1 Søjle	Column	Säule
36	61 020 52	1 Ventilbeslag	Valve bracket	Ventil Beschlag
37	61 020 60	1 Bagplade	Cover	Abdeckblech
38	61 020 63	1 Greb for ventil	Valve handle	Ventil griff
39	61 020 74	1 Pumpehåndtag	Pump handle	Pumpehebel
40	61 020 92	1 Blændplade	Plade	Schirm
41	70 012 40	1 Hydraulikrør	Hydraulic tube	Hydraulik Rohr
42	90 798 12	1 Luftslange	Air hose	Luftschlauch
43	90 971 00	1 Pumpe	Pump	Pump
44	90 971 06	1 Tryksko	Press head	Druckschuhe

61 020 30

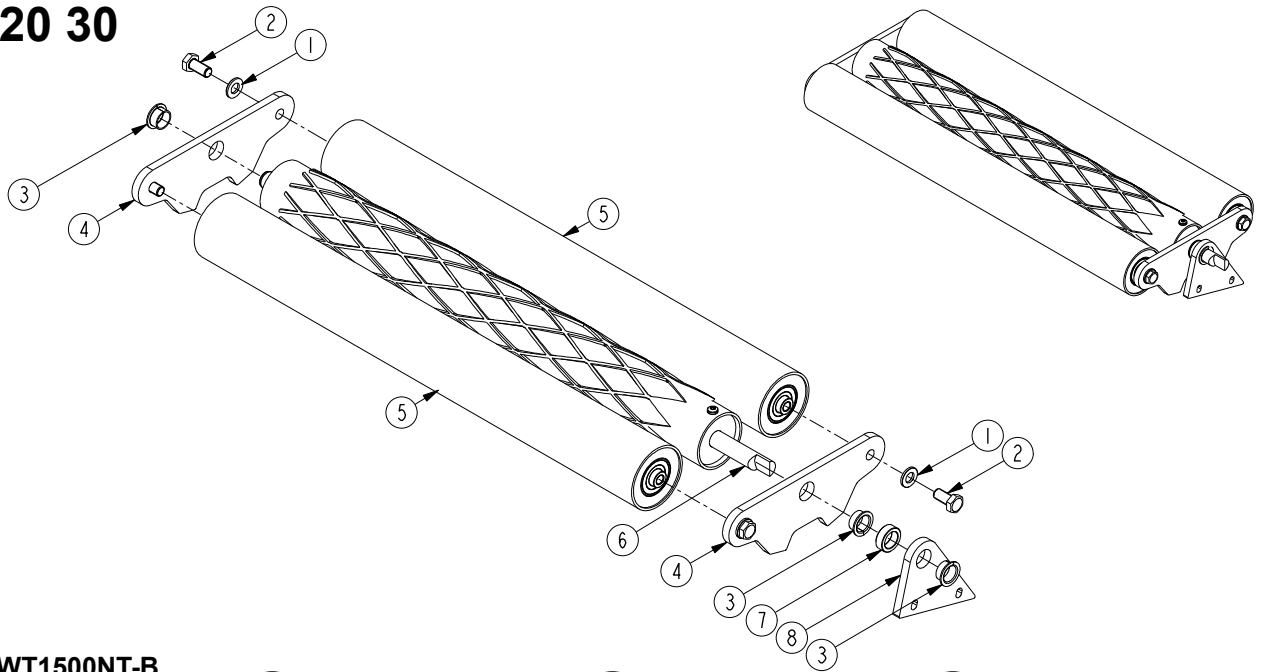

**WT1500NT-B
WT1500NT**

Pos.	Art. No.	Pcs.	(DK) Benævnelse	(GB) Description	(DE) Bezeichnung
	61 020 30		Ruller	Roller	Rollen
1	02 121 00	4	Skive	Washer	Scheibe
2	02 322 00	4	Skrue	Screw	Schraube
3	02 614 00	3	Leje	Bearing	Lager
4	61 020 33	2	Rullekonsol	Wheelframe	Fahrrahmen
5	61 020 50	2	Rulle	Roll	Roll
6	61 020 58	1	Rulle	Roll	Roll
7	61 021 21	1	Ring	Bushing	Buschse
8	61 021 22	1	Rullekonsol	Wheelframe	Fahrrahmen

61 020 32

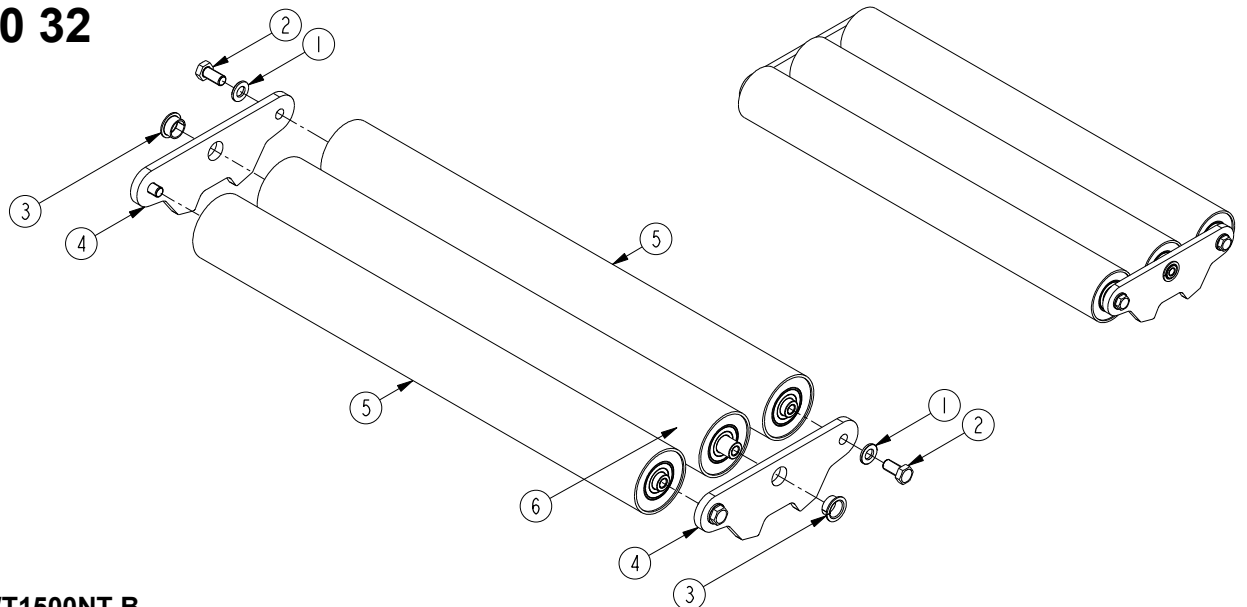

**WT1500NT-B
WT1500NT**

Pos.	Art. No.	WT1500NT Art. No.	(DK) Pcs. Benævnelse	(GB) Description	(DE) Bezeichnung
	61 020 32	61 020 32	Ruller	Roller	Rollen
1	02 121 00	02 121 00	4 Skive	Washer	Scheibe
2	02 322 00	02 322 00	4 Skrue	Screw	Schraube
3	02 614 00	02 614 00	2 Leje	Bearing	Lager
4	61 020 33	61 020 33	2 Rullekonsol	Wheelframe	Fahrrahmen
5	61 020 50	61 020 50	2 Rulle	Roll	Roll
6	61 020 54	61 020 54	1 Rulle	Roll	Roll

90 971 10

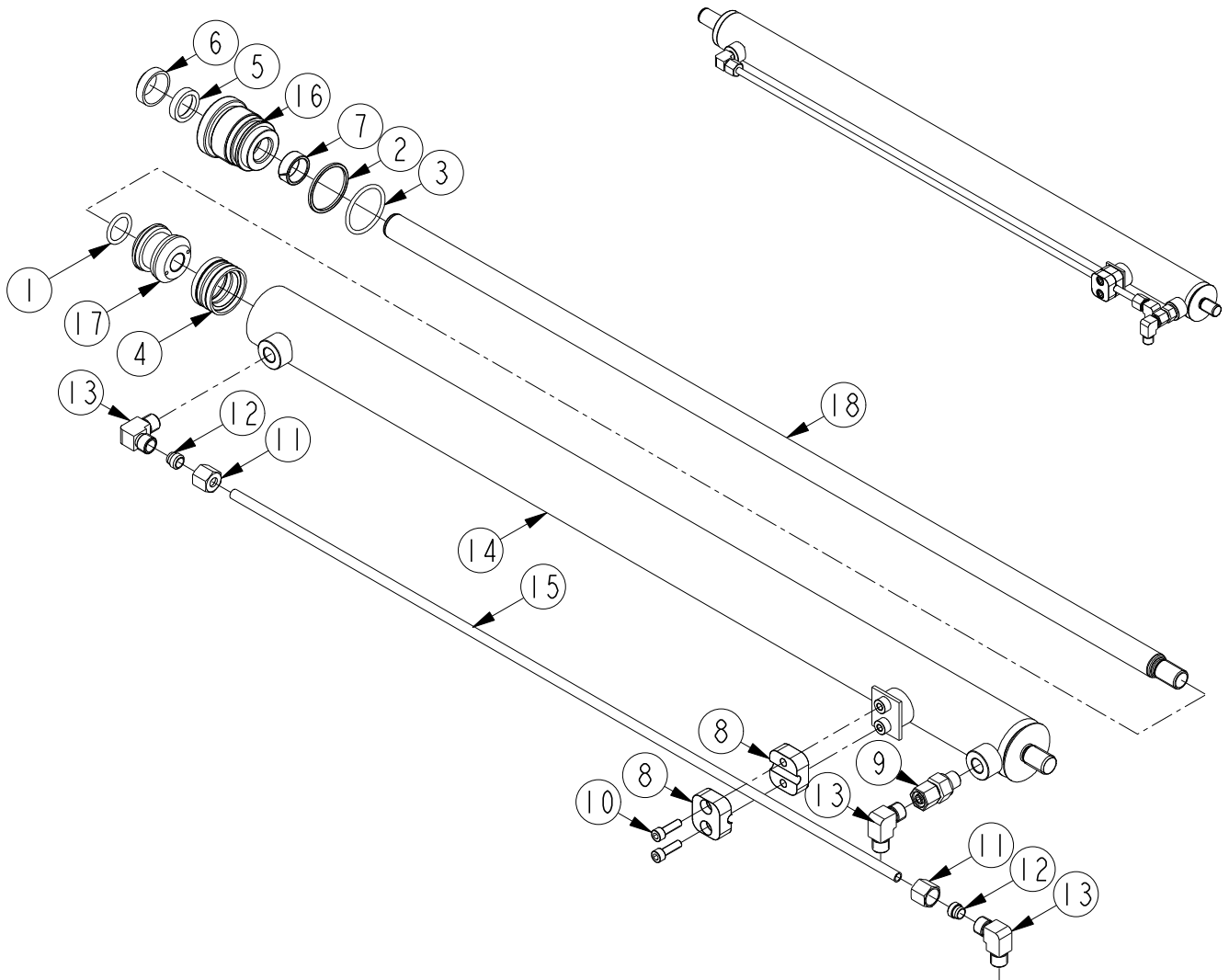

WT1500NT-B

WT1500NT

WT1500N

Pos.	Art. No.	Art. No.	(DK)	(GB)	(DE)
			Pcs. Benævnelse	Description	Bezeichnung
	90 971 10	90 971 10	Cylinder	Cylinder	Zylinder
*1	01 003 00	01 003 00	1 O-ring	O-ring	O-ring
*2	01 098 00	01 098 00	1 Støttering	Back-up ring	Stützring
*3	01 099 00	01 099 00	1 O-ring	O-ring	O-ring
*4	01 136 00	01 136 00	1 Pakning	Seal	Dichtung
*5	01 192 00	01 192 00	1 Pakning	Seal	Dichtung
*6	01 260 00	01 260 00	1 Afstryger	Scraper ring	Abstreifer
*7	01 372 00	01 372 00	1 Stytering	Wear ring	Verschleißring
8	02 006 94	02 006 94	2 Rørbærer	Pipe clamp	Halter für Rohr
9	02 007 11	02 007 11	1 Fitting	Fitting	Fitting
10	02 347 00	02 347 00	2 Skruer	Screw	Schraube
11	02 656 00	02 656 00	2 Omløber	Union nut	Überwurfmutter
12	02 657 00	02 657 00	2 Skæring	Ring	Sneidring
13	02 820 00	02 820 00	3 Fitting	Fitting	Fitting
14	90 971 08	90 971 08	1 Cylinder, svejst	Cylinder	Zylinder
15	90 971 11	90 971 11	1 Hydraulikrør	Hydraulic tube	Hydraulik Rohr
16	90 971 13	90 971 13	1 Pakboks	Packing box	Pakmutter
17	90 971 14	90 971 14	1 Stempel	Piston	Kolben
18	90 971 17	90 971 17	1 Stok	Piston rod	Kolbenstange
*	09 088 00	09 088 00	Pakningsæt	Repair kit	Dichtungssatz

90 971 00

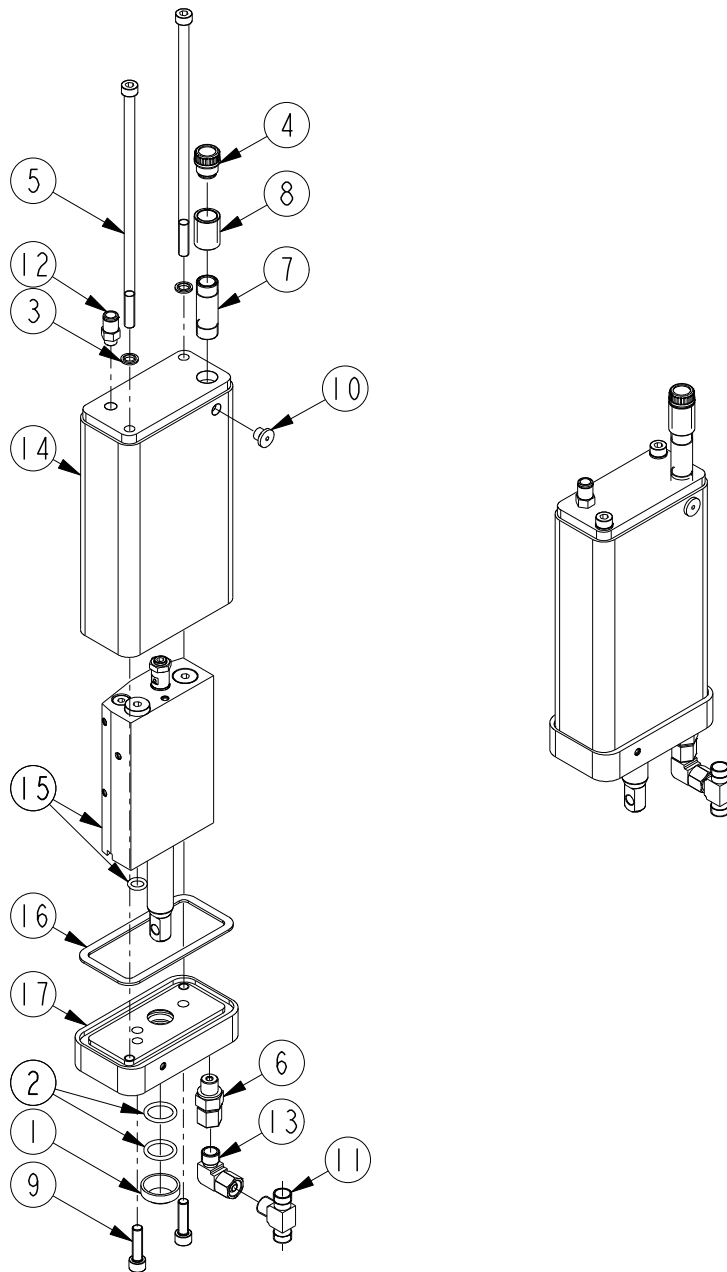

WT1500NT-B WT1500NT

WT1500N

Pos.	Art. No.	Art. No.	(DK)	(GB)	(DE)
			Pcs. Benævnelse	Description	Bezeichnung
	90 971 00	90 971 00	Pumpe	Pump	Pumpe
1	01 260 00	01 260 00	1 Afstryger	1 Scraper ring	1 Abstreifer
2	01 812 00	01 812 00	2 O-ring	2 O-ring	2 O-ring
3	01 816 00	01 816 00	2 Pakning	2 Seal	2 Dichtung
4	02 006 98	02 006 98	1 Olie prop	1 Plug	1 Pfropfen
5	02 006 99	02 006 99	2 Skruer	2 Screw	2 Schraube
6	02 007 11	02 007 11	1 Fitting	1 Fitting	1 Fitting
7	02 009 76	02 009 76	1 Fitting	1 Fitting	1 Fitting
8	02 009 77	02 009 77	1 Fitting	1 Fitting	1 Fitting
9	02 310 00	02 310 00	2 Skruer	2 Screw	2 Schraube
10	02 448 00	02 448 00	1 Prop	1 Plug	1 Pfropfen
11	02 486 00	02 486 00	1 Fitting	1 Fitting	1 Fitting
12	02 516 00	02 516 00	1 Fitting	1 Fitting	1 Fitting
13	02 863 00	02 863 00	1 Fitting	1 Fitting	1 Fitting
14	90 971 03	90 971 03	1 Tank	1 Reservoir	1 Ölbehälter
15	90 971 20	90 971 20	1 2-trins pumpe	1 2-stage pump	1 2-Stufen-Pumpe
16	90 971 24	90 971 24	1 Pakning	1 Seal	1 Dichtung
17	90 971 25	90 971 25	1 Tankbund	1 Reservoir bottom	1 Ölbehälterboden

90 971 20

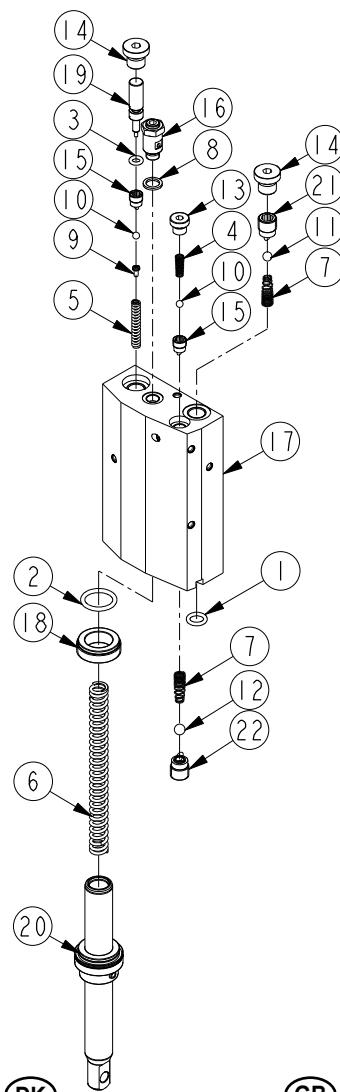
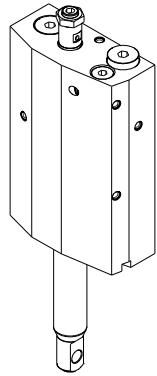

	WT1500NT-B	WT1500NT	WT1500N	(DK)	(GB)	(DE)
Pos.	Art. No.	Art. No.	Art. No.	Pcs. Benævnelse	Description	Bezeichnung
	90 971 20	90 971 20	90 971 20	2-trins pumpe	2-stage pump	2-Stufen-Pumpe
*1	01 000 00	01 000 00	01 000 00	1 O-ring	O-ring	O-Ring
*2	01 003 00	01 003 00	01 003 00	1 O-ring	O-ring	O-Ring
*3	01 088 00	01 088 00	01 088 00	1 O-ring	O-ring	O-Ring
4	02 000 12	02 000 12	02 000 12	1 Fjeder	Spring	Feder
5	02 004 73	02 004 73	02 004 73	1 Fjeder	Spring	Feder
6	02 004 76	02 004 76	02 004 76	1 Fjeder	Spring	Feder
7	02 068 00	02 068 00	02 068 00	2 Fjeder	Spring	Feder
8	02 082 00	02 082 00	02 082 00	1 Skive	Disc	Scheibe
9	02 155 00	02 155 00	02 155 00	1 Skruer	Screw	Schraube
*10	02 164 00	02 164 00	02 164 00	2 Kugle Ø5	Ball, Ø5	Kugel, Ø5
*11	02 292 00	02 292 00	02 292 00	1 Kugle Ø6.5	Ball, Ø6.5	Kugel, Ø6.5
*12	02 293 00	02 293 00	02 293 00	1 Kugle Ø7.5	Ball, Ø7.5	Kugel, Ø7.5
13	02 483 00	02 483 00	02 483 00	1 Prop	Plug	Pfropfen
14	02 584 00	02 584 00	02 584 00	2 Prop	Plug	Pfropfen
*15	90 695 00	90 695 00	90 695 00	2 Ventilindsats 1/8", Ø3.5	Valve core 1/8", Ø3,5	Ventileinsatz 1/8", Ø3,5
16	90 866 00	90 866 00	90 866 00	1 Overtryksventil	Safety valve	Überdruckventil
17	90 867 01	90 867 01	90 867 01	1 Pumpeblok	Pump block	Pumpblock
18	90 867 03	90 867 03	90 867 03	1 Stempelstyr	Piston guide	Kolbenführung
19	90 867 05	90 867 05	90 867 05	1 Ventilstempel	Valve piston	Ventilkolben
20	90 867 10	90 867 10	90 867 10	1 Pumpestempel	Pump piston	Pumpkolben
*21	91 128 00	91 128 00	91 128 00	1 Ventilindsats 1/4", Ø5	Valve core 1/4", Ø5	Ventileinsatz 1/4", Ø5
*22	91 128 60	91 128 60	91 128 60	1 Ventilindsats 1/4", Ø6	Valve core 1/4", Ø6	Ventileinsatz 1/4", Ø6
*	09 083 00	09 083 00	09 083 00	Pakningsæt	Repair kit	Dichtungssatz

DK: OBS: Yderligere pakninger på foregående side (9097100) er ikke inkluderet i pakningsæt 0908300!

GB: NOTE: Additional seals on the previous page (9097100) are not included in seal kit 0908300!

DE: HINWEIS: Zusätzliche Dichtungen auf der vorherigen Seite (9097100) sind nicht in Dichtungssatz 0908300 enthalten!

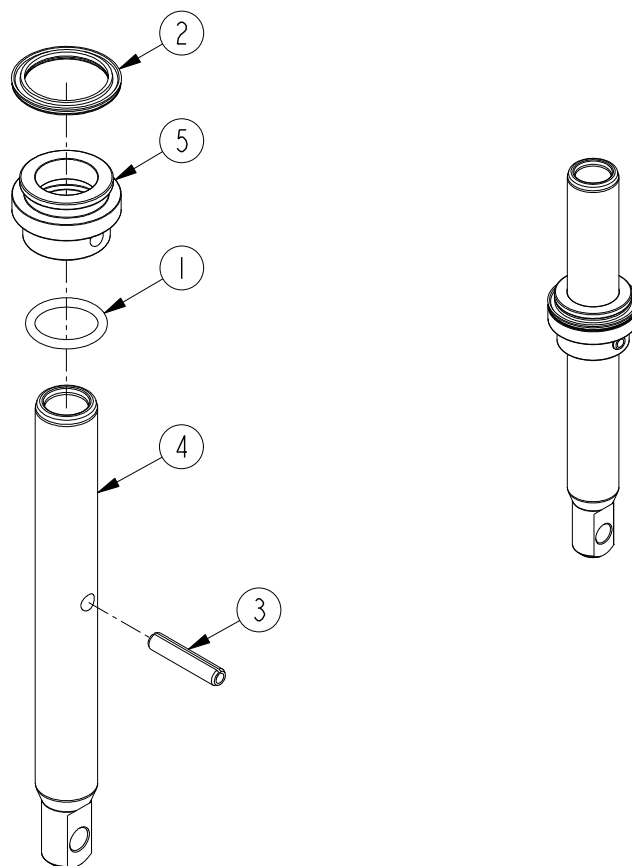

WT1500NT-B					
WT1500NT					
Pos.	Art. No.	Art. No.	(DK)	(GB)	(DE)
	90 867 10	90 867 10	Pcs. Benævnelse	Description	Bezeichnung
			Pumpestempel	Pump piston	Pumpkolben
*1	01 003 00	01 003 00	1 O-ring	O-ring	O-Ring
*2	01 638 00	01 638 00	1 Pakning	Seal	Dichtung
3	02 238 00	02 238 00	1 Spændstift	Pin	Stift
4	90 867 11	90 867 11	1 Pumpestempelstok	Pump piston rod	Kolbenstange
5	90 867 12	90 867 12	1 Stempel	Piston	Kolben
*	09 083 00	09 083 00	Pakningssæt, pumpe	Seal kit, pump	Dichtungssatz, Pumpe

DK: De med * mærkede dele leveres i komplet pakningssæt. Anvend altid originale reservedele. Angiv venligst altid model og reservedels-nummer. Alle hoveddele kan ikke forventes leveret efter produktionsophør af model.

GB: * indicate parts included in repair set. Please always state model and part number. Do always apply original spare parts.

DE: All major parts may not be provided as spare parts after discontinuation of production of a model.

DE: Die mit * markierten Teile sind im Dichtungssatz enthalten. Bitte immer Modell und Ersatzteilnummer auf Ihren Bestellungen angeben. Immer nur Originalteile verwenden. Lieferung von allen Hauptteilen als Ersatzteile kann nach Produktions-Einstellung eines Modelles nicht erwartet werden.

(DK) **HYDRAULIK DIAGRAM**
 (GB) **HYDRAULIC CHART**
 (DE) **HYDRAULISCHES DIAGRAMM**

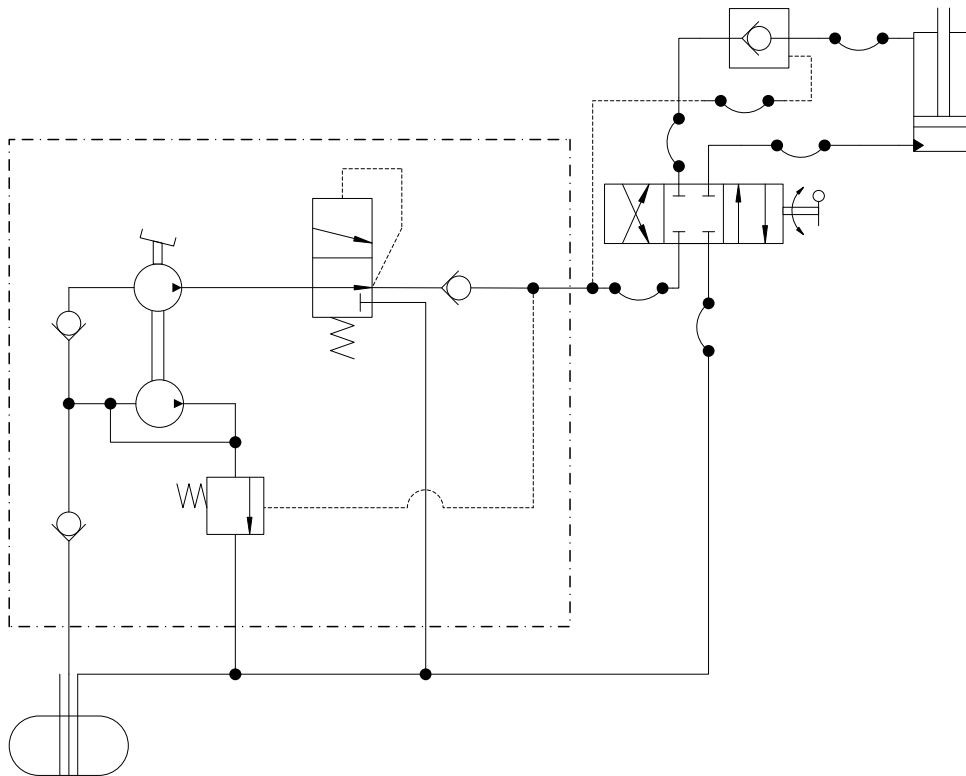

(DK) **TILBEHØR**
 (GB) **ACCESSORIES**
 (DE) **ZUBEHÖR**

Pos.	Art. No.	Pcs.	(DK) Benævnelse	(GB) Description	(DE) Bezeichnung
	61 022 00		Bremsekit	Breake set	Bremsanlage
1	02 002 30	8	Skrue	Screw	Schraube
2	02 007 36	2	Hjul	Wheel	Rad
3	02 116 00	8	Skive	Washer	Scheibe
4	02 312 00	8	Skrue	Screw	Schraube
5	61 022 01	2	Adapterplade	Adapter plate	Adapterplatte
6	61 022 02	2	Adapterplade	Adapter plate	Adapterplatte

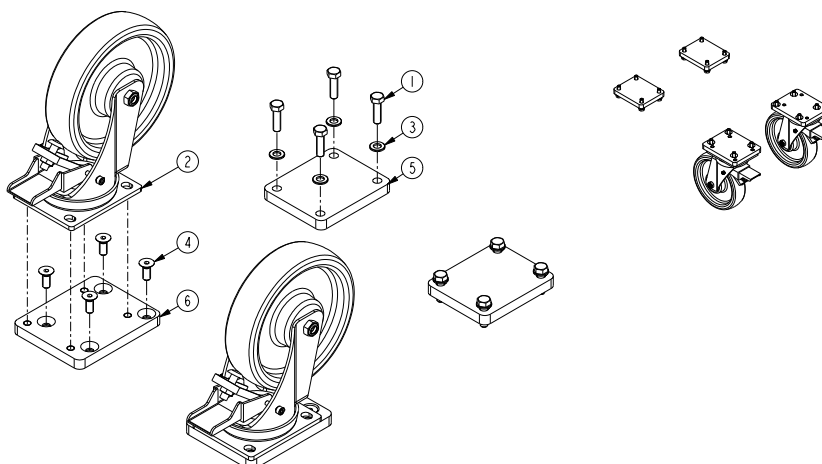

EU og UK Overensstemmelseserklæring
EU and UK Declaration of Conformity for Machinery
EG und UK Konformitätserklärung
Declaration CE et UK de conformité pour les
composants

EU och UK Överensstämelseförsäkran
EY ja UK Vaatimustenmukaisuuvakuutus
EU en UK verklaring van overeenstemming
Declaración CE y UK de conformidad
Dichiarazione UE e UK di conformità
ЕС и UK декларация соответствия

Directive 2006/42/EC

The Supply of Machinery (Safety) Regulations 2008

- (DK)** Hjulløfter,
WT1500NT, WT1500NT-B, WT1500N
(NO) er i overensstemmelse med Maskindirektivets bestemmelser 2006/42/EC, EN1494 og (The Supply of Machinery (Safety) Regulations 2008 (gælder kun for UK)).
Frederik Anker Christensen, Fanøvej 6, DK-8800 er bemyndiget til at udarbejde det tekniske dossier.
- (GB)** Wheel Removal Trolley,
WT1500NT, WT1500NT-B, WT1500N
are in conformity with the provisions of the Machinery Directive 2006/42/EC, EN1494 and (The Supply of Machinery (Safety) Regulations 2008 (UK only)).
Mr. Frederik Anker Christensen, Fanøvej 6, DK-8800 is authorized to compile the technical file.
- (DE)** Radmontagegerät,
WT1500NT, WT1500NT-B, WT1500N
konform sind mit den einschlägigen Bestimmungen der EG-Maschinenrichtlinie 2006/42/EC, EN1494 und (The Supply of Machinery (Safety) Regulations 2008 (UK only)).
Herr Frederik Anker Christensen, Fanøvej 6, DK-8800 ist berechtigt, die technischen Unterlagen zusammenzustellen.
- (FR)** Elevateur de roue,
WT1500NT, WT1500NT-B, WT1500N
sont conforme aux dispositions de la Directive Machine 2006/42/EC, EN1494 et (The Supply of Machinery (Safety) Regulations 2008 (UK only)).
Frederik Anker Christensen, Fanøvej 6, DK-8800 est autorisée à constituer le dossier technique.
- (SE)** Hjullyft,
WT1500NT, WT1500NT-B, WT1500N
Överensstämmer med Maskindirektivets bestämmelser 2006/42/EC, EN1494 och (The Supply of Machinery (Safety) Regulations 2008 (UK only)).
Frederik Anker Christensen, Fanøvej 6, DK-8800 är behörig att ställa samman den tekniska dokumentationen.
- (FI)** Käyttöohjeet,
WT1500NT, WT1500NT-B, WT1500N
vastaa Konedirektiivin 2006/42/EC, EN1494 ja (The Supply of Machinery (Safety) Regulations 2008 (UK only)).
Frederik Anker Christensen, Fanøvej 6, DK-8800 on valtuutettu kokoamaan teknisen tiedoston.
- (NL)** Wielheffers,
WT1500NT, WT1500NT-B, WT1500N
in overeenstemming zijn met de bepalingen van de Richtlijn Machines 2006/42/EC, EN1494 en (The Supply of Machinery (Safety) Regulations 2008 (UK only)).
Frederik Anker Christensen, Fanøvej 6, DK-8800 gemachtigd is om het technisch dossier samen te stellen.
- (ES)** Elevadores de ruedas,
WT1500NT, WT1500NT-B, WT1500N
Son conforme a las directrices sobre maquinaria Directiva 2006/42/EC, EN1494 y (The Supply of Machinery (Safety) Regulations 2008 (UK only)).
Frederik Anker Christensen, Fanøvej 6, DK-8800 está facultado para elaborar el expediente técnico.
- (IT)** Sollevatori de ruote,
WT1500NT, WT1500NT-B, WT1500N
sono in conformità con le disposizioni della Direttiva macchine (Direttiva 2006/42/CE, EN 1494 e (The Supply of Machinery (Safety) Regulations 2008 (UK only)).
Frederik Anker Christensen, Fanøvej 6, DK-8800 è autorizzato a costituire il fascicolo tecnico.
- (RU)** КОЛЕСНЫЕ ТЕЛЕЖКИ,
WT1500NT, WT1500NT-B, WT1500N
соответствуют положениям Директивы по машинному оборудованию (Директивы 2006/42/ЕС, EN 1494 и (The Supply of Machinery (Safety) Regulations 2008 (UK only)).
Frederik Anker Christensen, Fanøvej 6, DK-8800 уполномочен составлять техническую документацию.



AC Hydraulic A/S

Fanøvej 6
DK-8800 Viborg - Danmark
Tel.: +45 8662 2166
Fax: +45 8662 2988
E-mail: ac@ac-hydraulic.dk
www.ac-hydraulic.com

Frederik Anker Christensen
General Manager
Viborg 01.01.23

