

SERVICE - INFO



LuK Nr: 130 0004 10 – 320mm DGVM

Bulletin 988 1000 830

JOHN DEERE – 2130, 2135, 2640, 2840, 3030, 3120, 3130, 3135 Powershift

Info:	130 0004 10 replaces / ersetzt / remplace / sustituye a / sostituisce 130 0004 20
GB	Please ensure that flywheel is machined to $\varnothing 326 \pm 0.3$ mm and to a pot depth of 21.6 ± 0.25 mm. The clutch should be fitted with 6 x 3/8" UNC x 2 3/4" bolts.
D	Der Schwungraddurchmesser muss auf $\varnothing 326 \pm 0,3$ mm ausgedreht werden. Die Schwungradtiefe ist 21.6 ± 0.25 mm. Die LuK-Kupplungsdruckplatte ist mit Befestigungsschrauben 6 x 3/8" UNC x 2 3/4" zu verbauen.
F	Assurez-vous que le diamètre du volant-moteur a été alésé à $\varnothing 326 \pm 0,3$ mm et que la profondeur est de 21.6 ± 0.25 mm. L'embrayage doit être monté avec des vis de fixation 6 x 3/8" UNC x 2 3/4".
E	Por favor, asegúrese de que el volante-motor está mecanizado a $\varnothing 326 \pm 0,3$ mm y a una profundidad de 21.6 ± 0.25 mm en la zona de fricción. El embrague LuK debe ir montado con tornillos de fijación 6 x 3/8" UNC x 2 3/4".
I	Controllare il volano sia stato rettificato a $\varnothing 326 \pm 0,3$ mm e ad una profondità di 21.6 ± 0.25 mm. La frizione deve essere installata con 6 bulloni da 3/8" UNC x 2 3/4".



130 0004 20



130 0004 10



Flywheel
Schwungrad
Volant-moteur
Volante-motor
Volano

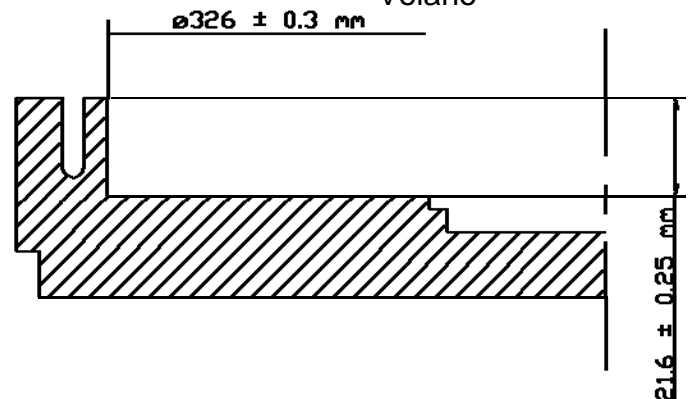

Issue Level 4

LuK Aftermarket Service UK Ltd.
Holme Lacy Road, Rotherwas
HR2 6LA Hereford · The United Kingdom
Phone: +44 1432 264264 · Fax +44 1432 275146
e-mail: LuK-AS.uk.pm@schaeffler.com
A Member of the Schaeffler Group

