



Catalogo generale ricambi

General spare parts catalogue

Catalogue générale des pièces de rechange

Ersatzteile-katalog

Catálogo de piezas



Battioni®
Pagani

Setting the pace since 1953



MEC 9000-11000-13500 / P

Rel. 0 del 15.01.2018

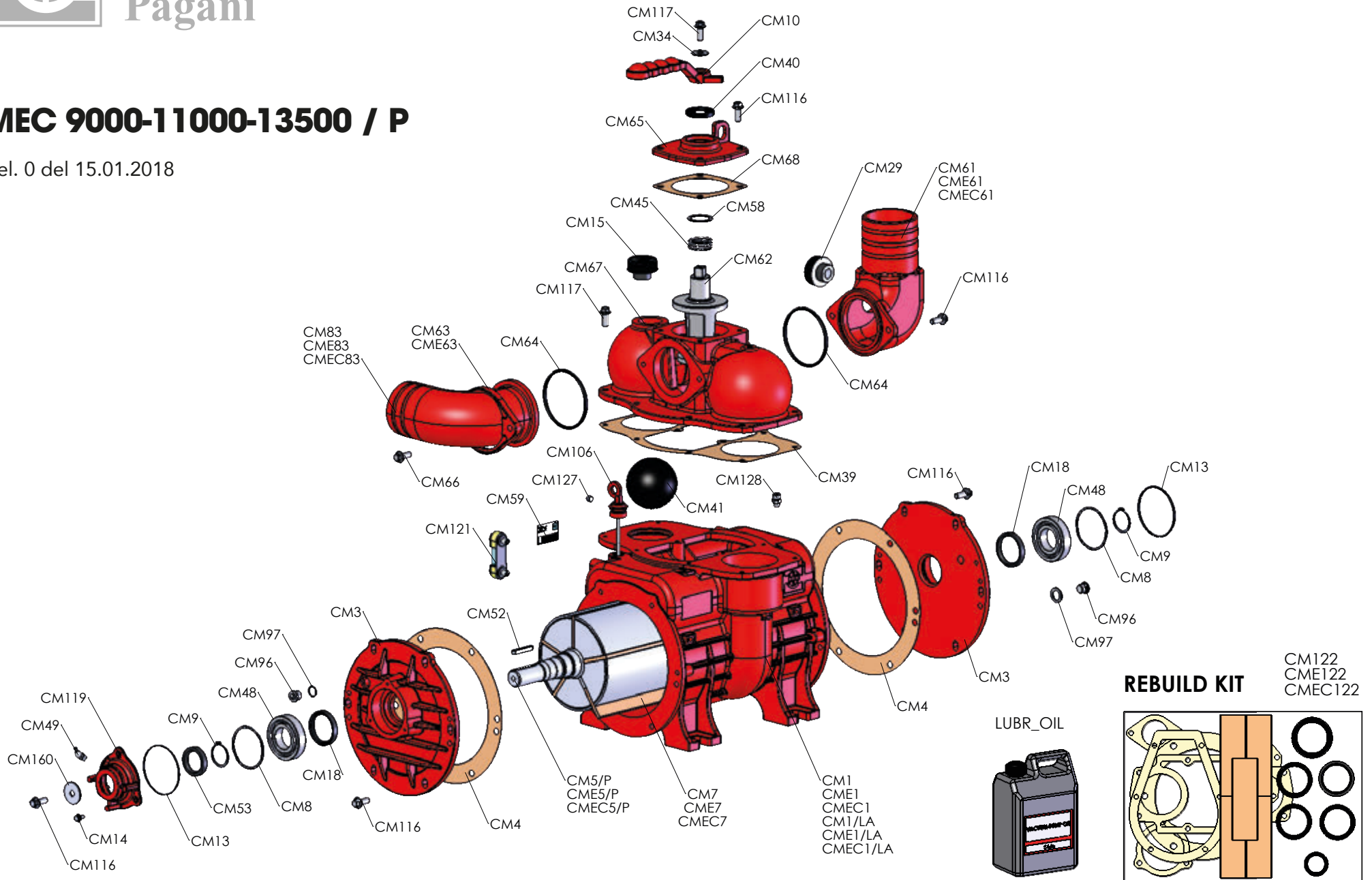

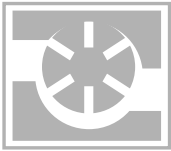

**Battioni®
Pagani**

MEC 9000/11000/13500

MEC 9000-11000-13500 / D

Rel. 0 del 15.01.2018

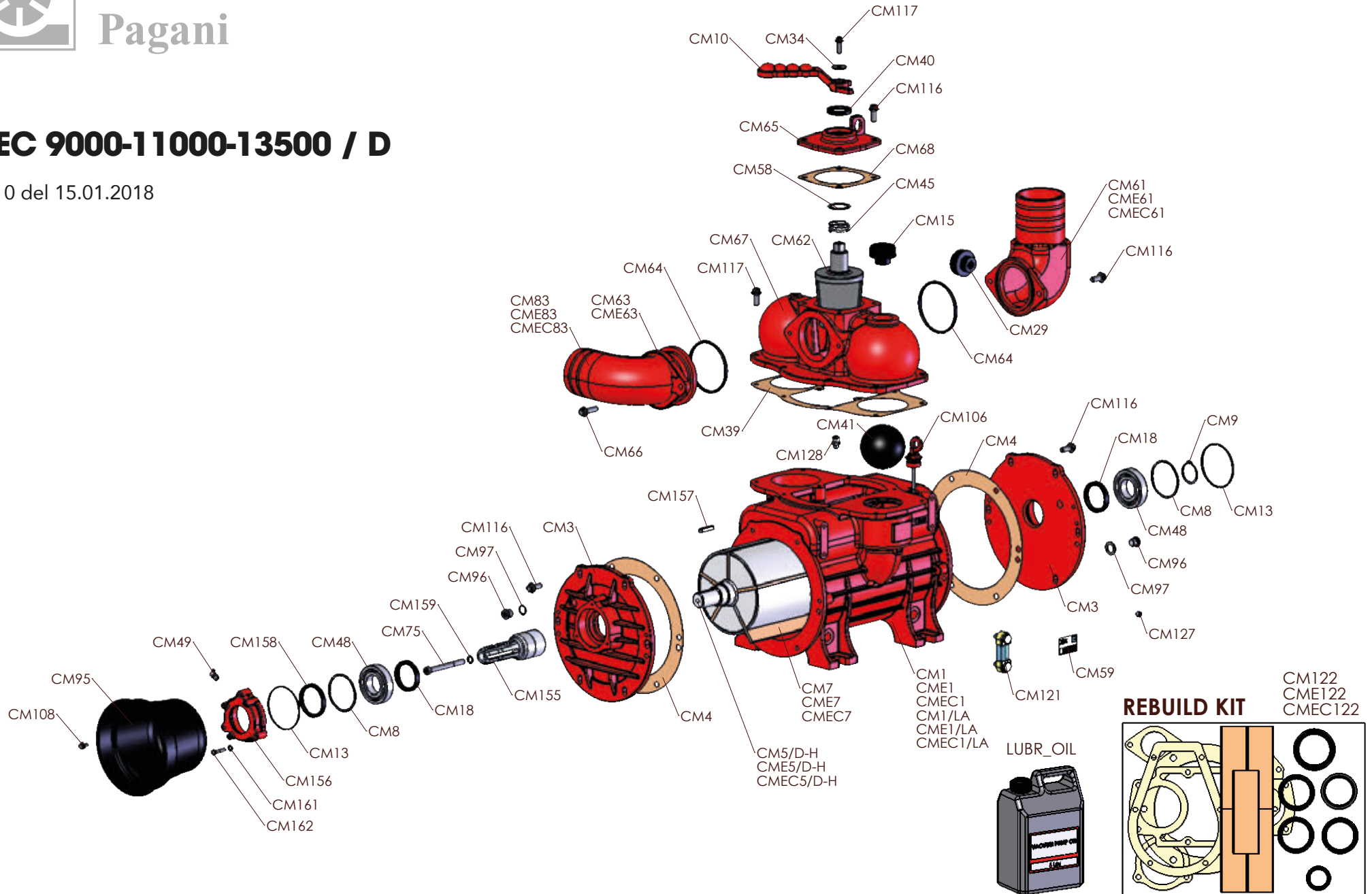



MEC 9000-11000-13500 / H

Rel. 0 del 15.01.2018

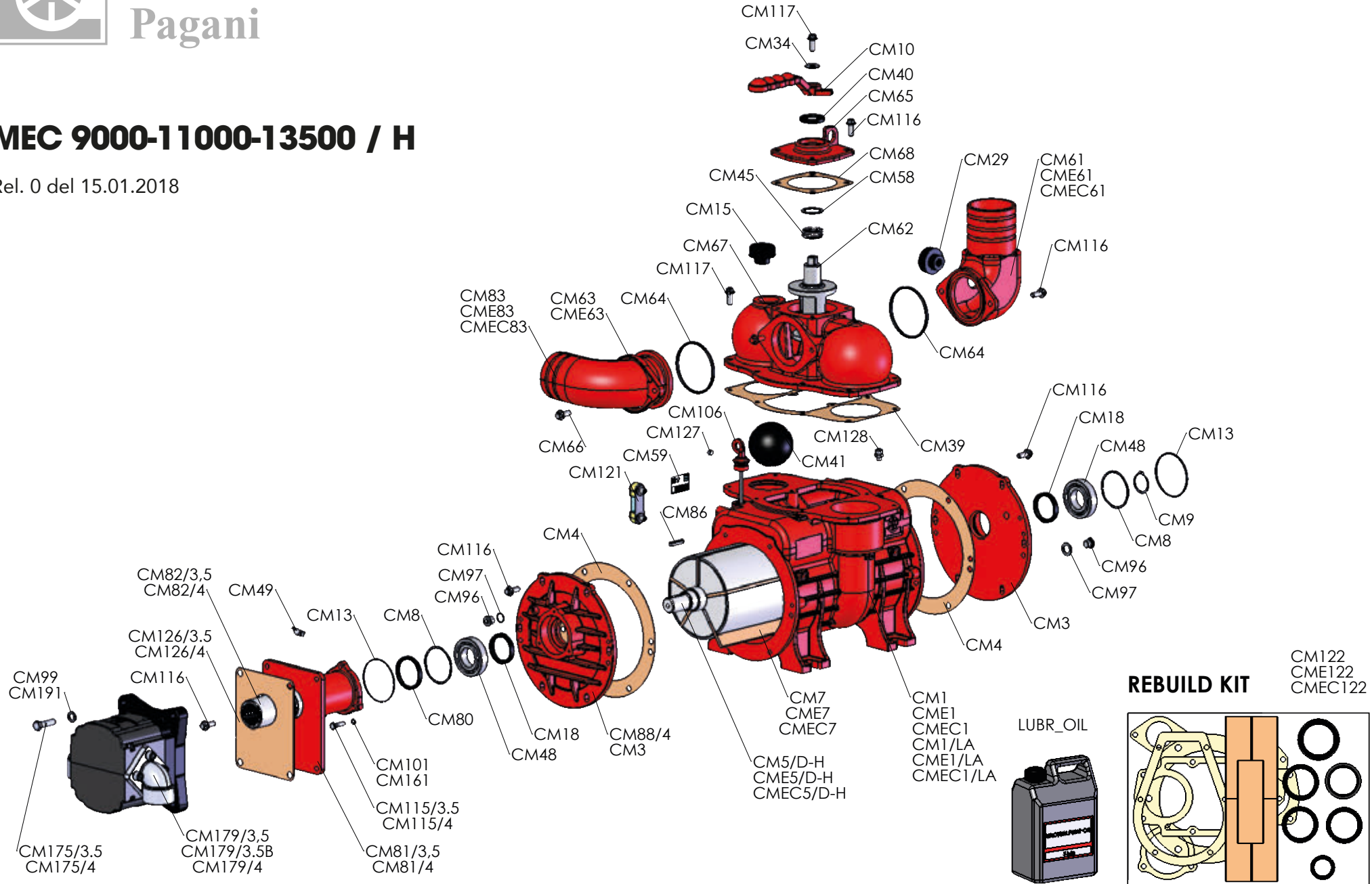

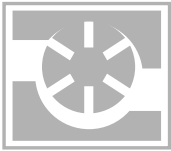

MEC 9000-11000-13500 / G-GA

Rel. 0 del 15.01.2018

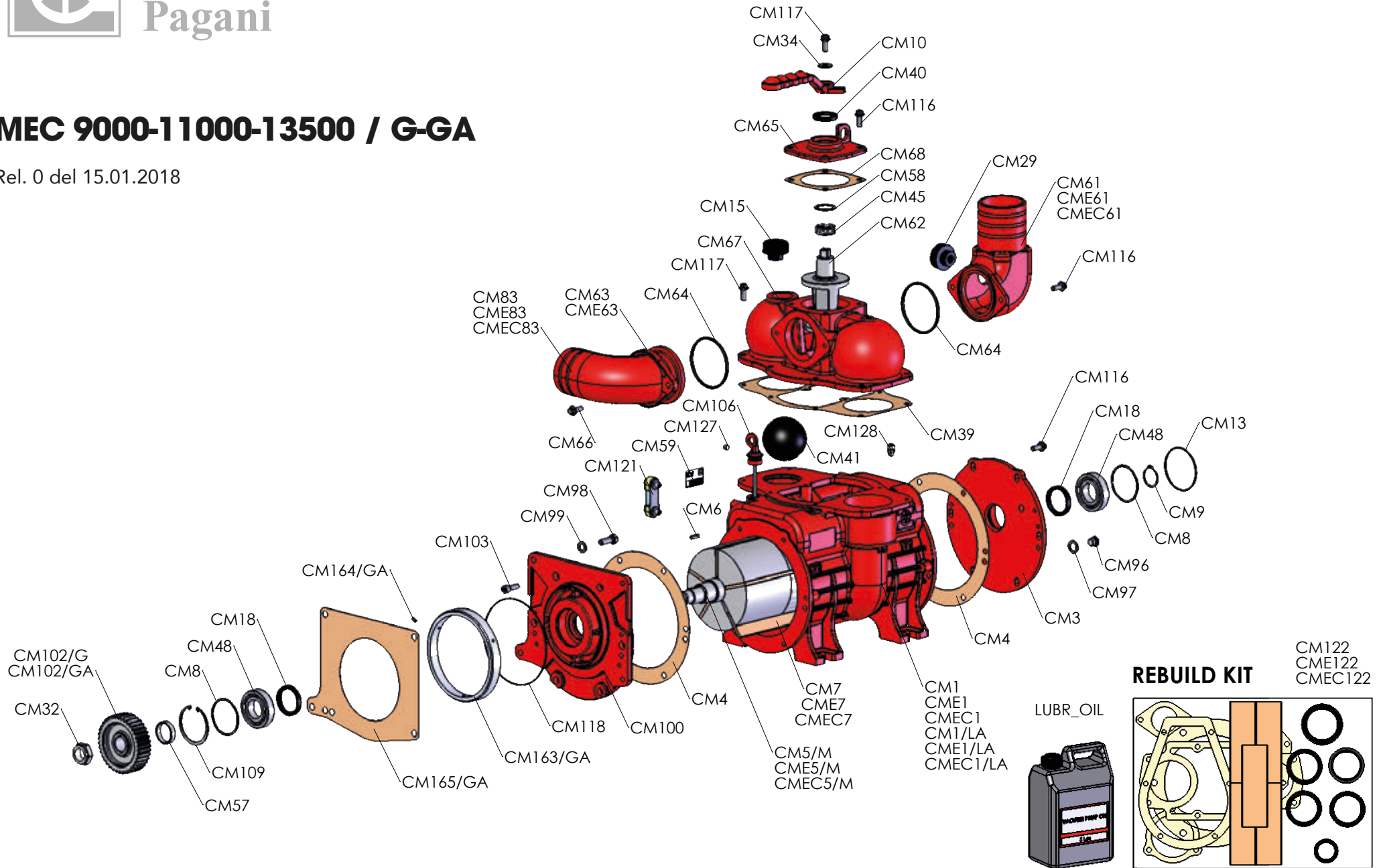



Battioni®
Pagani

MEC 9000-11000-13500 / U.L.

Rel. 0 del 15.01.2018

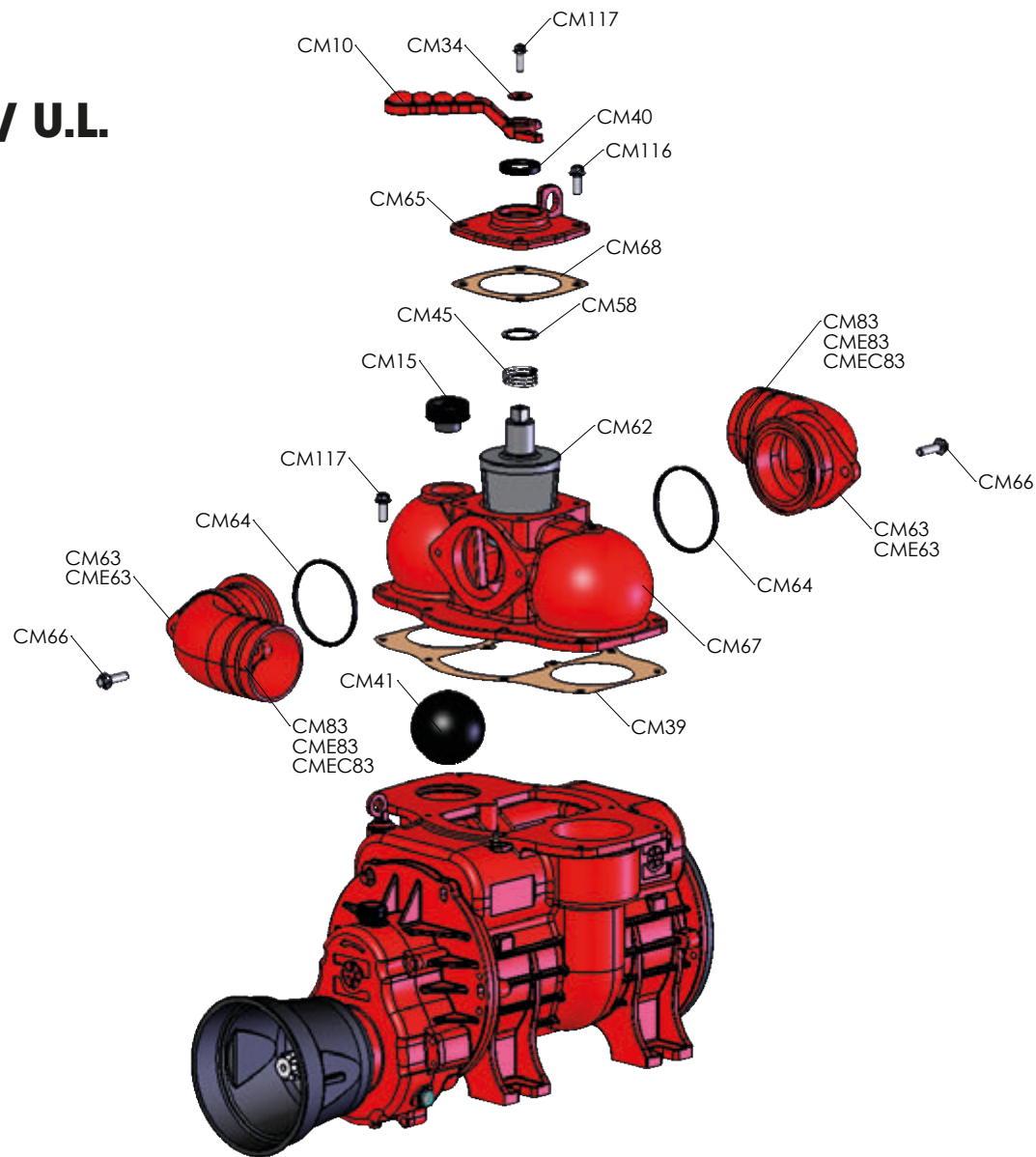



MEC 9000-11000-13500 / M - S.C.

Rel. 0 del 15.01.2018

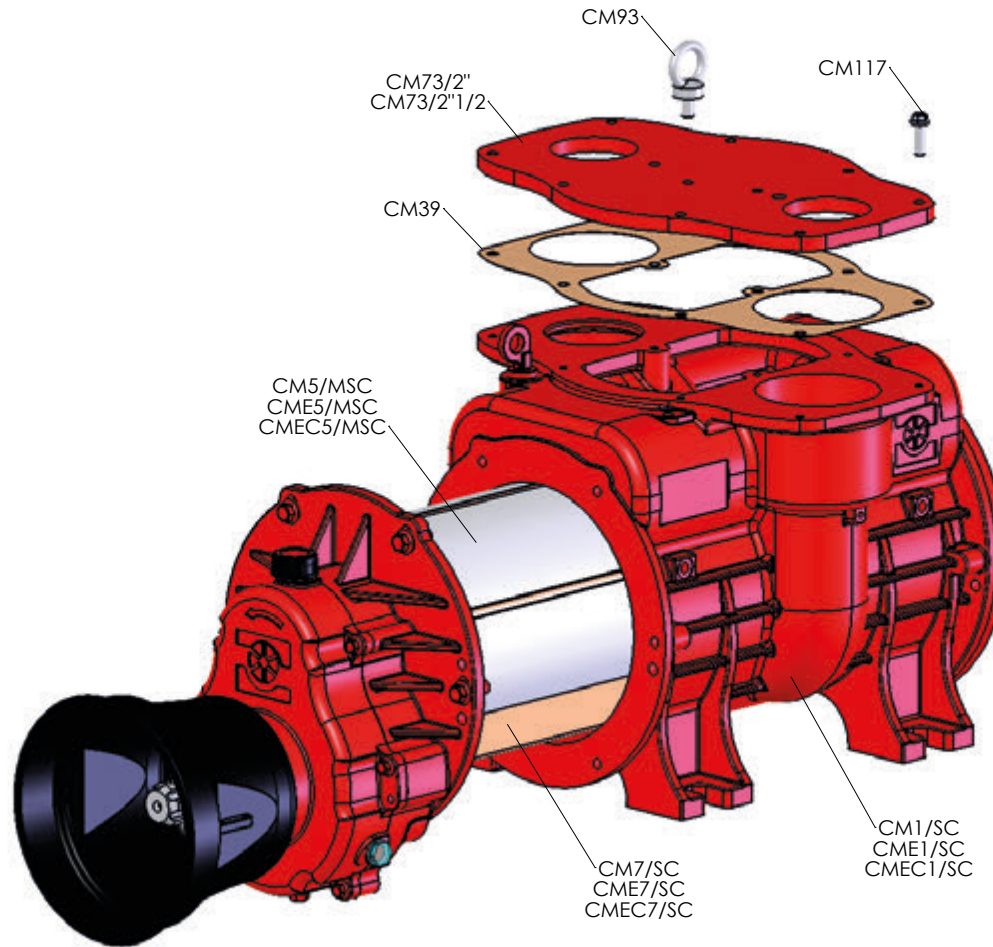

LUBR_OIL



REBUILD KIT
CM122/SC
CME122/SC
CMEC122/SC

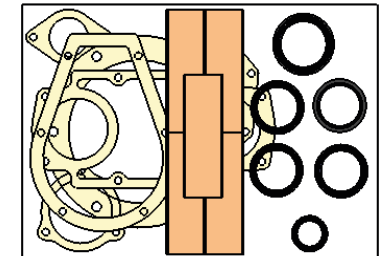



MEC 9000-11000-13500

<i>Articolo</i> (Article)	<i>Codice</i> (Code)	<i>Descrizione</i>	<i>(Description)</i>	<i>Q.ty</i>	<i>Um</i>
CM1	4010101085	CORPO POMPA MEC 9000 LF	HOUSING - MEC 9000 LF	1	pcs
CM1/LA	4010101101	CORPO POMPA MEC 9000 LA	HOUSING - MEC 9000 LA	1	pcs
CM1/SC	4010101113	CORPO POMPA MEC 9000 SC LF	HOUSING - MEC 9000 SC LF	1	pcs
CME1	4010101086	CORPO POMPA MEC 11000 LF	HOUSING - MEC 11000 LF	1	pcs
CME1/LA	4010101104	CORPO POMPA MEC 11000 LA	HOUSING - MEC 11000 LA	1	pcs
CME1/SC	4010101107	CORPO POMPA MEC 11000 SC LF	HOUSING - MEC 11000 SC LF	1	pcs
CMEC1	4010101087	CORPO POMPA MEC 13500 LF	HOUSING - MEC 13500 LF	1	pcs
CMEC1/LA	4010101108	CORPO POMPA MEC 13500 LA	HOUSING - MEC 13500 LA	1	pcs
CMEC1/SC	4010101114	CORPO POMPA MEC 13500 SC LF	HOUSING - MEC 13500 SC LF	1	pcs
CM2	4010301028	SCATOLA MOLT. MEC 9000-11000-13500/M	GEARBOX - MEC 9000-11000-13500/M	1	pcs
CM3	4010401061	FLANGIA ANT. POST. MEC 9000-11000-13500	FRONT & BACK FLANGE MEC 9000-11000-13500	1	pcs
CM4	4030108048	GUARN. FLANGIA MEC 9-11-13500	BODY GASKET MEC 9-11-13500	2	pcs
CM5/M10	4010220175	ROTORE MEC 9000/M CH.D10	ROTOR - MEC 9000/M KEY 10	1	pcs
CME5/M10	4010220176	ROTORE MEC 11000/M CH.D10	ROTOR - MEC 11000/M KEY 10	1	pcs
CMEC5/M10	4010220177	ROTORE MEC 13500/M CH.D10	ROTOR - MEC 13500/M KEY 10	1	pcs
CM5/MSC	4010220181	ROTORE MEC 9000/M SENZA COLL. CH.10	ROTOR - MEC 9000/M SC KEY 10	1	pcs
CME5/MSC	4010220182	ROTORE MEC 11000/M SENZA COLL. CH.10	ROTOR - MEC 11000/M SC KEY 10	1	pcs
CMEC5/MSC	4010220183	ROTORE MEC 13500/M SENZA COLL. CH.10	ROTOR - MEC 13500/M SC KEY 10	1	pcs
CM5/P	4010220147	ROTORE MEC 9000/P	ROTOR - MEC 9000/P	1	pcs
CME5/P	4010220148	ROTORE MEC 11000/P	ROTOR - MEC 11000/P	1	pcs



MEC 9000-11000-13500

<i>Articolo</i> (Article)	<i>Codice</i> (Code)	<i>Descrizione</i>	<i>(Description)</i>	<i>Q.ty</i>	<i>Um</i>
CMEC5/P	4010220149	ROTORE MEC 13500/P	ROTOR - MEC 13500/P	1	pcs
CM5/H	4010220150	ROTORE MEC 9000/H	ROTOR - MEC 9000/H	1	pcs
CME5/H	4010220151	ROTORE MEC 11000/H	ROTOR - MEC 11000/H	1	pcs
CMEC5/H	4010220152	ROTORE MEC 13500/H	ROTOR - MEC 13500/H	1	pcs
CM5/D10	4010220169	ROTORE MEC 9000/D CH.10	ROTOR - MEC 9000/D KEY 10	1	pcs
CME5/D10	4010220170	ROTORE MEC 11000/D CH.10	ROTOR - MEC 11000/D KEY 10	1	pcs
CMEC5/D10	4010220171	ROTORE MEC 13500/D CH.10	ROTOR - MEC 13500/D KEY 10	1	pcs
CM6	5050707032	CHIAVETTA 10X8X25	KEY - 10X8X25	1	pcs
CM6/A	4011806029	CHIAVETTA RIDUZ. 10X8>6X6 X25 MEC2 MA/GA	REDUCTION KEY - MEC2 MA/GA 10X8>6X6 X25	1	pcs
CM7	4070113192	PALETTA LONG LIFE MEC 9000 300X60X6,5	LONG LIFE BLADE MEC 9000 300X60X6,5	5	pcs
CME7	4070113193	PALETTA LONG LIFE MEC 11000 370X60X6,5	LONG LIFE BLADE MEC 11000 360X60X6,5	5	pcs
CMEC7	4070113194	PALETTA LONG LIFE MEC 13500 460X60X6,5	LONG LIFE BLADE MEC 13500 460X60X6,5	5	pcs
CM7/SC	4070113198	PALETTA STANDARD MEC 9000 299X60X9,7	STANDARD BLADE - MEC 9000 299X60X9,7	5	pcs
CME7/SC	4070113199	PALETTA STANDARD MEC 11000 369X60X9,7	STANDARD BLADE - MEC 11000 369X60X9,7	5	pcs
CMEC7/SC	4070113200	PALETTA STANDARD MEC 13500 458X60X9,7	STANDARD BLADE - MEC 13500 458X60X9,7	5	pcs
CM8	5012207001	ANELLO DI COMPENSAZIONE Ø 80	COMPRESSION & THRUST RING D80	2	pcs
CM9	5050507017	ANELLO SEEGER D 40 E - DIN 471 -	CIRCLIP - D 40 E - DIN 471	1	pcs
CM10	4010801043	MANIGLIA MEC 9-13500	HANDLE - MEC 9-13500	1	pcs
CM12	5012107010	CUSCINETTO A SFERE 6307	BALL BEARING - 6307	1	pcs
CM13	5030210028	ANELLO TENUTA OR 2337-85.34X1.78POMPA LF	SEAL RING - OR 2337 85.34X1.78 LF PUMP	2	pcs



MEC 9000-11000-13500

<i>Articolo</i> (Article)	<i>Codice</i> (Code)	<i>Descrizione</i>	<i>(Description)</i>	<i>Q.ty</i>	<i>Um</i>
CM14	5050107005	VITE M 6X16 TE	SCREW - M 6X16 TE	5	pcs
CM15	5040303015	TAPPO NERO D 2" GAS	BLACK PLUG - D 2" GAS	1	pcs
CM18	5030300041	PARAOLIO 48X62X10 DCV	OIL SEAL - 48X62X10 DCV	2	pcs
CM21	5060605001	TAPPO CARICO OLIO D 3/8" GAS	OIL PLUG - D 3/8" GAS	1	pcs
CM23	5050107018	VITE M 10X16 TE	SCREW - M 10X16 TE	1	pcs
CM24	5050202002	RONDELLA D 10X16X1,5 ALLUMINIO	ALUMINIUM WASHER - D 10X16X1,5	4	pcs
CM25	5012107006	CUSCINETTO A SFERE 6304	BALL BEARING - 6304	1	pcs
CM26/M	4020507003	INGR. CON ALBERO MEC 6,5-8000 Z53-M2,5	GEAR WITH SHAFT - Z53-M2,5 MEC 6,5-8000	1	pcs
CM26/MA	4020507012	INGR. CON ALBERO MEC9-13500/MA Z43-M2,5	GEAR WITH SHAFT MEC9-13500/MA Z43-M2,5	1	pcs
CM27	5030300005	PARAOLIO 35X62X10	OIL SEAL - 35X62X10	1	pcs
CM28	4030108049	GUARN. COPERCHIO MOLT. MEC 9-11-13500	GEARBOX COVER GASKET MEC 9-11-13500	1	pcs
CM29	5060605005	TAPPO NERO D 1"1/2 GAS	BLACK CAP - D 1"1/2 GAS	1	pcs
CM30	5060105004	TAPPO LIVELLO OLIO D 3/8" GAS	OIL LEVEL PLUG - D 3/8" GAS	1	pcs
CM32	5050300002	DADO AUTOBLOCCANTE M 27X2X16	SELF-LOCKING NUT - M 27X2X16	1	pcs
CM33/M10	4020607059	PIGNONE MEC 9-11-13500/M Z23-M2,5	PINION MEC 9-11-13500/M Z23-M2,5	1	pcs
CM33/MA	4020607057	PIGNONE MEC 9-11-13500/MA Z33-M2,5	PINION MEC 9-11-13500/MA Z33-M2,5	1	pcs
CM34	5050207032	RONDELLA D 10X28X4 - DIN 6340	WASHER - D 10X28X4 - DIN 6340	1	pcs
CM39	4030109035	GUARN. COLLETTORE MEC 9-11-13500	MANIFOLD GASKET MEC 9-11-13500	1	pcs
CM40	5030300015	PARAOLIO 35X50X7 TC	OIL SEAL - 35X50X7 TC	1	pcs
CM41	5060410007	SFERA IN GOMMA PESANTE D 90	RUBBER BALL - D 90	1	pcs



MEC 9000-11000-13500

<i>Articolo</i> (Article)	<i>Codice</i> (Code)	<i>Descrizione</i>	<i>(Description)</i>	<i>Q.ty</i>	<i>Um</i>
CM45	4012007011	MOLLA MEC 9-11-13500	SPRING - MEC 9-11-13500	1	pcs
CM48	5012107004	CUSCINETTO A SFERE 6208	BALL BEARING - 6208	2	pcs
CM49	5050812001	INGRASSATORE M 10X1	LUBRICATOR - M 10X1	1	pcs
CM52	5050707007	CHIAVETTA 8X7X50	KEY - 8X7X50	1	pcs
CM53	5030300002	PARAOILIO 35X52X10	OIL SEAL - 35X52X10	1	pcs
CM57	4011707067	DISTANZIALE ROTORE MEC 9-11-13500 M-G	SPACER ROTOR M MEC 9-11-13500 M-G	1	pcs
CM58	5050207031	RONDELLA PER CONO INVERT. MEC 9-11-13500	TEFLON WASHER REV.GEAR MEC 9-11-13500	1	pcs
CM59	5101800000	THERMO LABEL	THERMO LABEL	1	pcs
CM61	4011501030	CURVA ASPIRAZIONE D 76 MEC 9-11-13500	SUCTION ELBOW D 76 MEC 9-11-13500	1	pcs
CME61	4011501031	CURVA ASPIRAZIONE D 80 MEC 9-11-13500	SUCTION ELBOW D 80 MEC 9-11-13500	1	pcs
CMEC61	4011501032	CURVA ASPIRAZIONE D 100 MEC 9-11-13500	SUCTION ELBOW D 100 MEC 9-11-13500	1	pcs
CM62	4010701018	CONO INVERTITORE MEC 9-13500	REVERSING GEAR MEC 9-13500	1	pcs
CM63	4010406017	FLANGIA PREMICURVA D 80 - STAR	FLANGE FOR ELBOW - STAR D80	2	pcs
CME63	4010406015	FLANGIA PREMICURVA D 100 - STAR	FLANGE FOR ELBOW - STAR D100	2	pcs
CM64	5030210008	ANELLO TENUTA OR 189 STAR UL	SEAL RING - OR 189 STAR UL	2	pcs
CM65	4010601056	COPERCHIO COLL.MEC 9_13500-STAR-WPT/UL	MANIFOLD COVER - MEC 9_13500-STAR-WPT/UL	1	pcs
CM66	5050107054	VITE M 10X35 TE	SCREW - M 10X35 TE	2	pcs
CM67	4010501026	COLLETTORE MEC 9000-11000-13500	MANIFOLD MEC 9000-11000-13500	1	pcs
CM68	4030109025	GUARN. COP.COLL. MEC 9_13500-STAR-WPT/UL	MANIFOLD COVER GASK-MEC 9_13500-STAR-WPT/UL	1	pcs
CM73/2"	4010606020	COPERCHIO SERBATOIO 2" MEC 9000	OIL TANK COVER 2" MEC 9000	1	pcs



MEC 9000-11000-13500

<i>Articolo</i> (Article)	<i>Codice</i> (Code)	<i>Descrizione</i>	<i>(Description)</i>	<i>Q.ty</i>	<i>Um</i>
CM73/2"5	4010606021	COPERCHIO SERBATOIO 2"1/2 MEC 11-13500	OIL TANK COVER 2"1/2 MEC 11-13500	1	pcs
CM80	5030300013	PARAOLIO 55X68X8	OIL SEAL - 55X68X8	1	pcs
CM81/3,5	4011001016	SUPPORTO MOTORE IDR.MEC 2-11000/H GR.3,5	HYDR. MOT. SUPPORT - MEC 2-11000/H GR.3,5	1	pcs
CM81/4	4011001059	SUPPORTO MOTORE IDR. MEC9-11-11000/H GR4	HYDRAULIC MOTOR SUPP MEC9-11-13500/H GR4	1	pcs
CM82/3,5	4020107027	MANICOTTO TRASM. MOT. IDR.MEC 9-11000 GR 3,5	HYDR.MOTOR TRANSM.COUPLING MEC 9-11000 GR 3,5	1	pcs
CM82/4	4020107024	MANICOTTO TRASM. MOT. IDR.MEC 9-13500 GR4	HYDR.MOTOR TRANSM.COUPLING MEC 9-11-13500 GR4	1	pcs
CM83	4010901018	CURVA SCAR. ORIENT.MEC 9_13500-STAR D 76	REVOLVING ELBOW - MEC 9_13500-STAR D 76	2	pcs
CME83	4010901019	CURVA SCAR. ORIENT.MEC 9_13500-STAR D 80	REVOLVING ELBOW - MEC 9_13500-STAR D 80	2	pcs
CMEC83	4010901020	CURVA SCAR. ORIENT.MEC 9_13500-STAR D100	REVOLVING ELBOW - MEC 9_13500-STAR D 100	2	pcs
CM86	5050707015	CHIAVETTA 8X7X40	KEY - 8X7X40	1	pcs
CM88/4	4010401063	FLANGIA ANT. MEC 9-13500/H	FRONT FLANGE - MEC 9-13500 /H	1	pcs
CM93	5051206001	GOLFARE MASCHIO M 10 - CE	MALE EYEBOLT - M 10 - CE	1	pcs
CM94	4010601154	COPERCHIO SCATOLA MOLT. MEC 9-11-13500	GEARBOX COVER - MEC 9-11-13500	1	pcs
CM95	4060505000	PROTEZIONE ALBERO CE	SHAFT GUARD - CE	1	pcs
CM96	5050906006	TAPPO D 16x1.5 - DIN 908 -	PLUG - D 16X1 DIN 908	1	pcs
CM97	5050202007	RONDELLA D 16X20X1,5 ALLUMINIO	ALUMINIUM WASHER - D 16X20X1,5	1	pcs
CM98	5050107028	VITE M 12X35 TE	SCREW - M 12X35 TE	4	pcs
CM100	4010401062	FLANGIA SUPPORTO DEC. MEC 9-11-13500/G	PUMP SUPP. FLANGE MEC 9-11-13500/G	1	pcs
CM101	5050207003	RONDELLA D 8	SMOOTH WASHER - D 8	3	pcs
CM102/G	4020607005	PIGNONE DEC. GARDA MEC 6,5-8000 Z39-M3	GARDA PINION - Z39-M3 MEC 6,5-8000	1	pcs



MEC 9000-11000-13500

<i>Articolo</i> (Article)	<i>Codice</i> (Code)	<i>Descrizione</i>	<i>(Description)</i>	<i>Q.ty</i>	<i>Um</i>
CM102/GA	4020607017	PIGNONE DEC. GARDA MEC 6,5-8000 GA Z50-M3	GARDA PINION - Z50-M3 MEC 6,5-8000 GA	1	pcs
CM103	5050107026	VITE M 10X25 TCEI	SCREW - M 10X25 TCEI	6	pcs
CM106	5060100001	ASTA LIVELLO OLIO 18X55 MM	OIL LEVEL ROD - MM 18X55	1	pcs
CM108	5050107107	VITE M 6x10 TEF - FL/ZIGR 8.8 -	GALVANIZED SCREW - M 6X10 TEF	4	pcs
CM109	5050507011	ANELLO SEEGER D 80 I	CIRCLIP - D 80 I	1	pcs
CM115/3,5	5050107122	VITE M 6X25 TE - 10.9 -	SCREW - M 6X25 TE - 10.9 -	3	pcs
CM115/4	5050107123	VITE M 8X25 TE - 10.9	SCREW - M 8X25 TE - 10.9	3	pcs
CM116	5050107109	VITE M 10X25 TEF - FL/ZIGR 8.8	SCREW - M 10X25 TEF - FL/ZIGR 8.8	12	pcs
CM117	5050107108	VITE M 8X25 TEF - FL/ZIGR 8.8	SCREW - M 8X25 TEF - FL/ZIGR 8.8	8	pcs
CM118	5030210063	ANELLO TENUTA OR 177.47X2.62	SEAL RING - OR 177.47X2.62	1	pcs
CM119	4010601153	COPERCHIO ANTERIORE MEC 5-13500 /P-AL	FRONT COVER - MEC 5-13500/P AL	1	pcs
CM121	4060505039	SPIA LIVELLO OLIO MEC 9000-11000-13500	OIL LEVEL INDICATOR MEC 9000-11000-13500	1	pcs
CM126/3,5	4030108046	GUARN. SUPP. MOTORE IDR. GR. 3-3.5 MEC	HYDR. MOT. SUPP. GASKET - GR. 3-3.5 - MEC	1	pcs
CM126/4	4030108028	GUARN. SUPP. MOTORE IDR. GRUPPO 4	HYDRAULIC MOTOR SUPPORT GASKET - GR4	1	pcs
CM127	5050903003	TAPPO D. 1/8" - DIN 906	PLUG - D 1/8" DIN 906	7	pcs
CM128	5050903004	TAPPO M 10x1 - CON SFIATO	PLUG - M 10X1 WITH AIR RELEASING	1	pcs
CM154	5050107125	VITE M 10X110 TCEI	SCREW - M 10X110 TCEI	1	pcs
CM155	4020107028	PRESA CALETTATA FORO D 32 -CH.10-Ø 1"3/8	SPLINED HUB HOLE D 32 -KEY 10 - D 1" 3/8	1	pcs
CM156	4010601167	COPERCHIO ANTERIORE MEC 9-11-13500 /D	FRONT COVER - MEC 9-11-13500/D	1	pcs
CM157	5050707031	CHIAVETTA 10X8X40	KEY - 10X8X40	1	pcs



MEC 9000-11000-13500

<i>Articolo</i> (Article)	<i>Codice</i> (Code)	<i>Descrizione</i>	<i>(Description)</i>	<i>Q.ty</i>	<i>Um</i>
CM158	5030300048	PARAOLIO 54X68X10 TC	OIL SEAL - 54X68X10 TC	1	pcs
CM159	5050207034	RONDELLA DI SICUREZZA D 10	SECURITY WASHER - D10	1	pcs
CM160	5050207008	RONDELLA TRANCIATA D 10X40	BLANK WASHER - D 10X40	1	psc
CM161	5050207002	RONDELLA D 6	SMOOTH WASHER - D 6	3	pcs
CM162	5050107157	VITE M 6X40 TE	SCREW - M 6X40 TE	3	pcs
CM163/GA	4011707024	ANELLO DI RID.SUPP.POMPA WPT 1000 GARDA	FLANGE RING NUT - WPT/G 1000 RPM	1	pcs
CM164/GA	5051007001	GRANO M 6X10	DOWEL - M 6X10	3	pcs
CM165/GA	4030108047	GUARN. FLANGIA SUPP. MEC9-13500/GA	DEC. SUPPORT GASKET - MEC9-13500/GA	1	pcs
CM166	4020607051	PIGNONE DEC. GARDA MEC/GA 2 LEVE	GARDA PINION - MEC/GA 2 LEVE	1	pcs
CM167	4020907069	ALBERO CONVERSIONE GARDA T MEC/STAR	SPLINED SLEEVE - GARDA T MEC/STAR	1	n
CM168	5050107016	VITE M 8X25 TCEI	SCREW - M 8X25 TCEI	8	n
CM170	5050107099	VITE ZINCATA M 10X45 TE	GALVANIZED SCREW - M 10X45 TE	1	n
CM171	4011707055	RONDELLA BLOCCAGGIO CALETTATO GARDA T	SPLINED SMOOTH WASHER - GARDA T	1	n
CM172	4020107034	MOZZO SCORREVOLE GARDA EVO	SLIDING SLEEVE - GARDA EVO	1	n
CM173	5050507029	ANELLO SEEGER D 55 E - DIN 471	CIRCLIP - D 55 E - DIN 471	1	n
CM174	4011707115	DISTANZIALE PERNO GA T	SPACER PIN GA T	1	n
CM175/3,5	5050107099	VITE ZINCATA M 10X45 TE	GALVANIZED SCREW - M 10X45 TE	4	pcs
CM175/4	5050107061	VITE M 12X45 TCEI	SCREW - M 12X45 TCEI	4	pcs
CM176	5050107009	VITE M 8X20 TE	SCREW - M 8X20 TE	1	pcs
CM177	4010501029	COLLETTORE MEC 9-11-13500 DU	MANIFOLD - MEC 9-11-135000 DU	1	pcs



MEC 9000-11000-13500

<i>Articolo</i> (Article)	<i>Codice</i> (Code)	<i>Descrizione</i>	<i>(Description)</i>	<i>Q.ty</i>	<i>Um</i>
CM178	4010801005	SELETTORE INVERTITORE STAR-WPT	REVERSE SELECTOR - STAR-WPT	1	pcs
CM179/3,5	6080200057	MOTORE IDR. KM 30.51 SO GR.3.5 COMPL.	HYDRAULIC MOTOR KM 30.51 SO GR. 3.5	1	pcs
CM179/3,5B	6080200059	MOTORE IDR. KM 30.73 SO GR.3.5 COMPL.	HYDRAULIC MOTOR KM 30.73 SO GR. 3.5	1	pcs
CM179/4	6080200061	MOTORE IDR. KM 40.87 SO GR.4 COMPL.	HYDRAULIC MOTOR KM 40.87 SO GR.4	1	pcs
CM180	4010701009	CONO INVERTITORE MEC 9-13500 DU	REVERSING GEAR - MEC 9-13500 DU	1	pcs
CM181	4011501002	CANNOTTO PORTATUBO MEC 9-11-13500 D80 DU	SLEEVE - MEC 9-11-13500 D 80 DU	2	pcs
CM182	4030109019	GUARN. CANNOTTO PORTATUBO MEC 9-13500 DU	MANIFOLD COVER GASKET -MEC 9-13500 DU	2	pcs
CM183	5060010001	POMOLO MANIGLIA WPT-STAR	HANDLE KNOB - D 3/8" GAS	1	pcs
CM184	4012007004	MOLLA STAR-WPT	SPRING - STAR-WPT	1	pcs
CM185	4030109018	GUARN. COPERCHIO COLL. MEC 9-11-13500 DU	MANIFOLD COVER GASKET - MEC 9-11-13500 DU	1	pcs
CM186	4010601044	COPERCHIO COLLETTORE MEC 9-11-13500 DU	MANIFOLD COVER - MEC 9-11-13500 DU	1	pcs
CM187	4050412014	PRIGIONIERO M 8X25 UNI 5911 - DIN 939	STUD BOLT - M 8X25 UNI 5911 - DIN 939	2	pcs
CM188	5050207023	RONDELLA D 8 ZINCATA	GALVANIZED FLAT WASHER - D 8	2	pcs
CM189	5050307007	DADO M 8 ZINCATO	NUT - M 8 GALVANIZED	2	pcs
CM190	5050307004	DADO M 12	NUT - M 12	1	pcs
CM192	4011912001	PERNO MANIGLIA STAR-WPT	HANDLE PIN - STAR-WPT	1	pcs
CM122	6010201045	KIT REVISIONE POMPA MEC 9000 LONG LIFE	REBUILD KIT - MEC 9000 LONG LIFE	1	pcs
CME122	6010201046	KIT REVISIONE POMPA MEC 11000 LONG LIFE	REBUILD KIT - MEC 11000 LONG LIFE	1	pcs
CMEC122	6010201047	KIT REVISIONE POMPA MEC 13500 LONG LIFE	REBUILD KIT - MEC 13500 LONG LIFE	1	pcs
CM122/SC	6010201051	KIT REVISIONE POMPA MEC 9000 M S.C.	REBUILD KIT - MEC 9000 M S.C.	1	pcs



MEC 9000-11000-13500

<i>Articolo</i> (Article)	<i>Codice</i> (Code)	<i>Descrizione</i>	<i>(Description)</i>	<i>Q.ty</i>	<i>Um</i>
CME122/SC	6010201052	KIT REVISIONE POMPA MEC 11000 M S.C.	REBUILD KIT - MEC 11000 M S.C.	1	pcs
CMEC122/SC	6010201053	KIT REVISIONE POMPA MEC 13500 M S.C.	REBUILD KIT - MEC 13500 M S.C.	1	pcs
LUBR_OIL	5070200100	OLIO BATTIONI PAGANI POMPE (5LT)	BATTIONI PAGANI VACUUM PUMP OIL (5LT)	1	pcs



Battioni®
Pagani

Setting the pace since 1953

0	15.01.2018	1° EMISSIONE	PROG	R DT	AM
REV.	DATA	MOTIVO	PREPARATO	APPROVATO	AUTORIZZATO



Battioni®
Pagani

Setting the pace since 1953

Via Cav. Enzo Ferrari, 2
43058 Ramoscello di Sorbolo (PR) - Italy

Ph. +39 0521 663203

Fax +39 0521 663206



www.bapag.it
info@bapag.it



Catalogo generale ricambi

General spare parts catalogue

Catalogue générale des pièces de rechange

Ersatzteile-katalog

Catálogo de piezas



Battioni®
Pagani

Setting the pace since 1953



Forced lubrication MEC 2000-3000-4000-5000

Rel. 0 del 15.01.2018

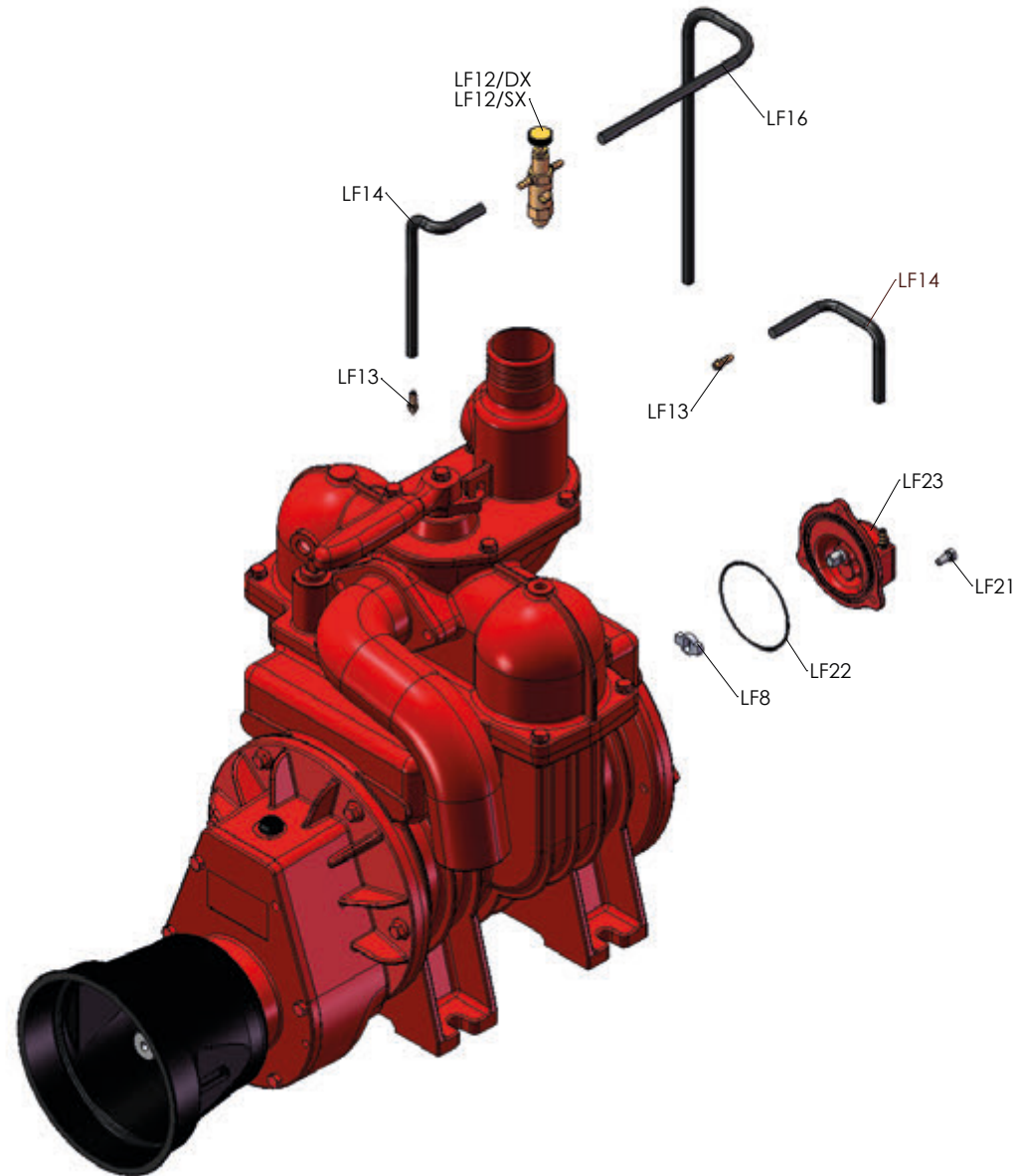



Battioni®
Pagani

Automatic lubrication MEC 1000-1600-2000-3000-4000-5000

Rel. 0 del 15.01.2018

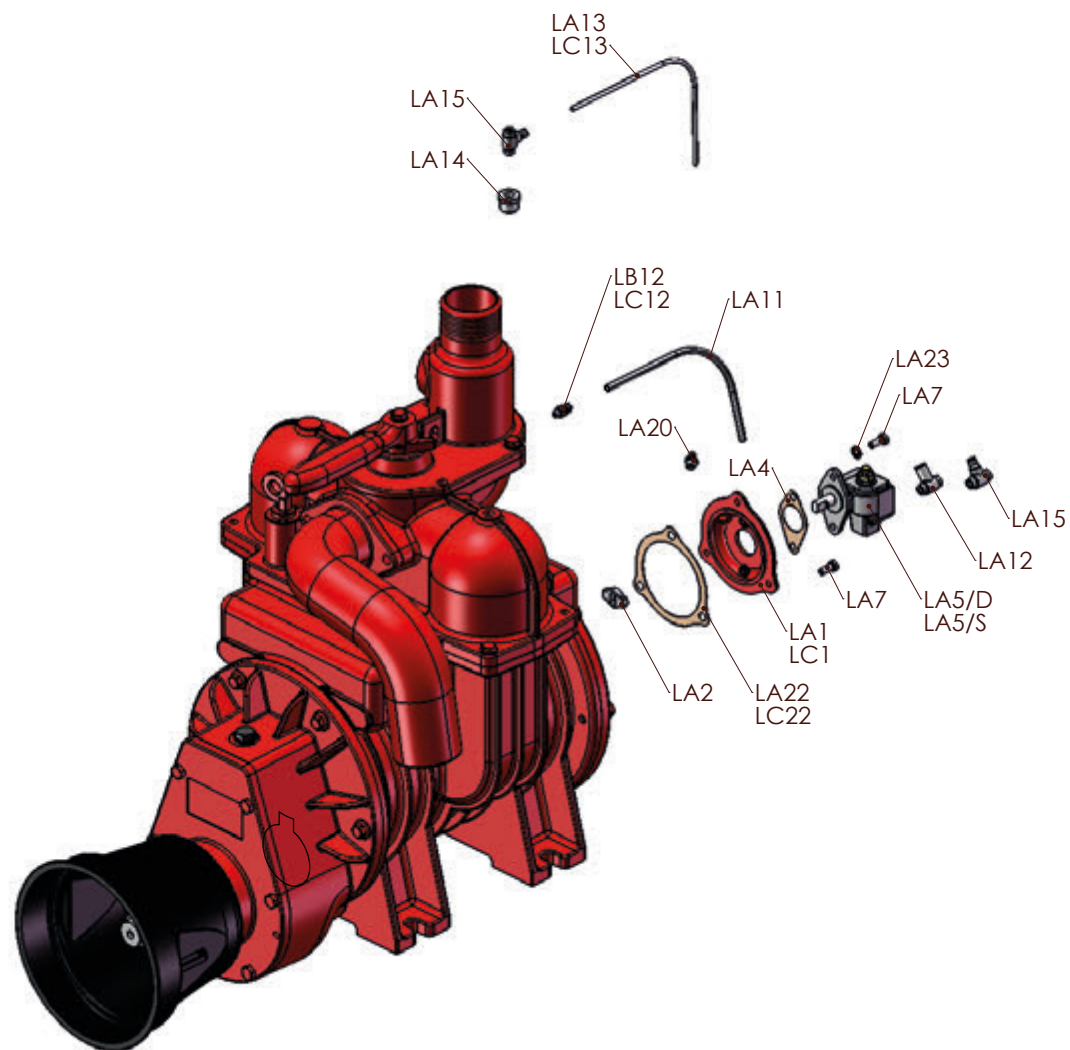



Forceed lubrication MEC 6500-8000

Rel. 0 del 15.01.2018

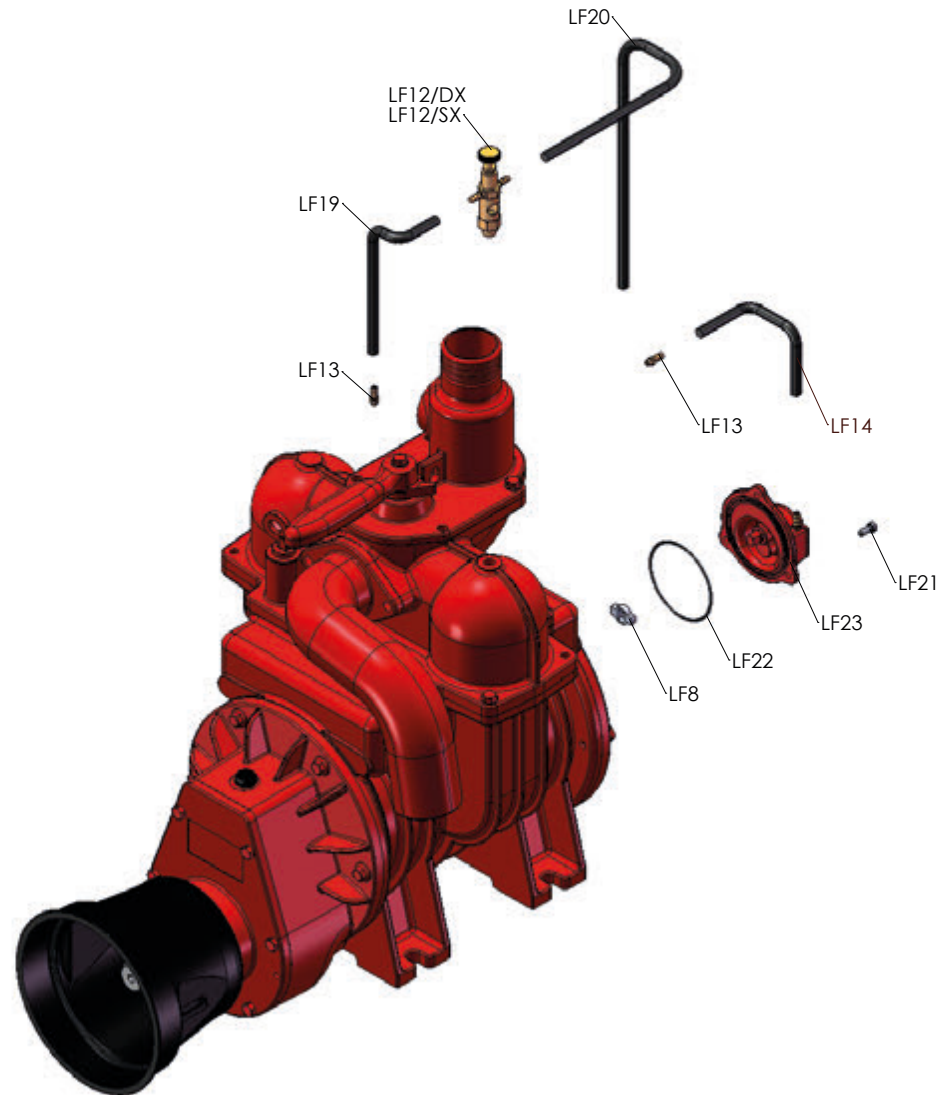



Battioni®
Pasani

Automatic lubrication MEC 6500-8000

Rel. 0 del 15.01.2018

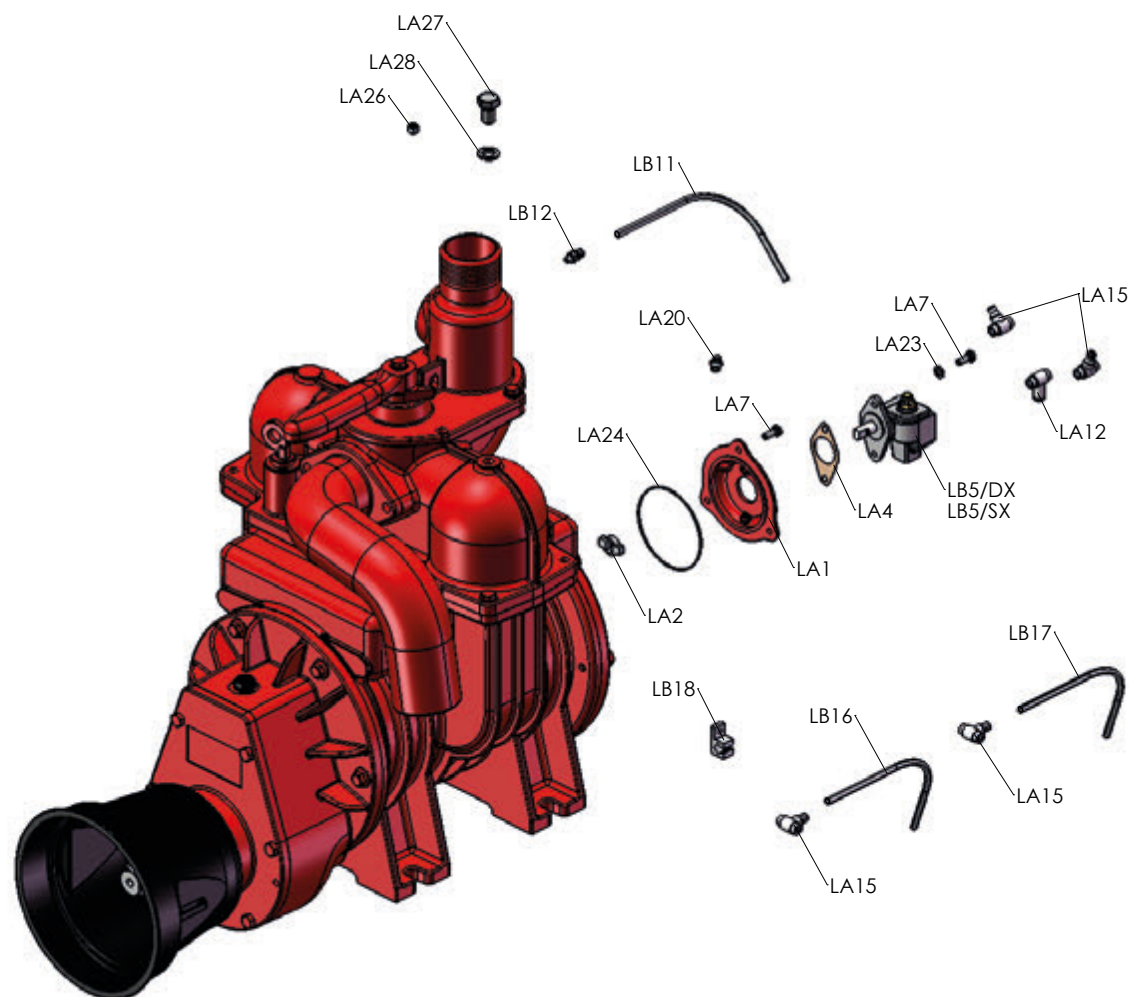



Forced lubrication MEC 9000-11000-13500

Rel. 0 del 15.01.2018

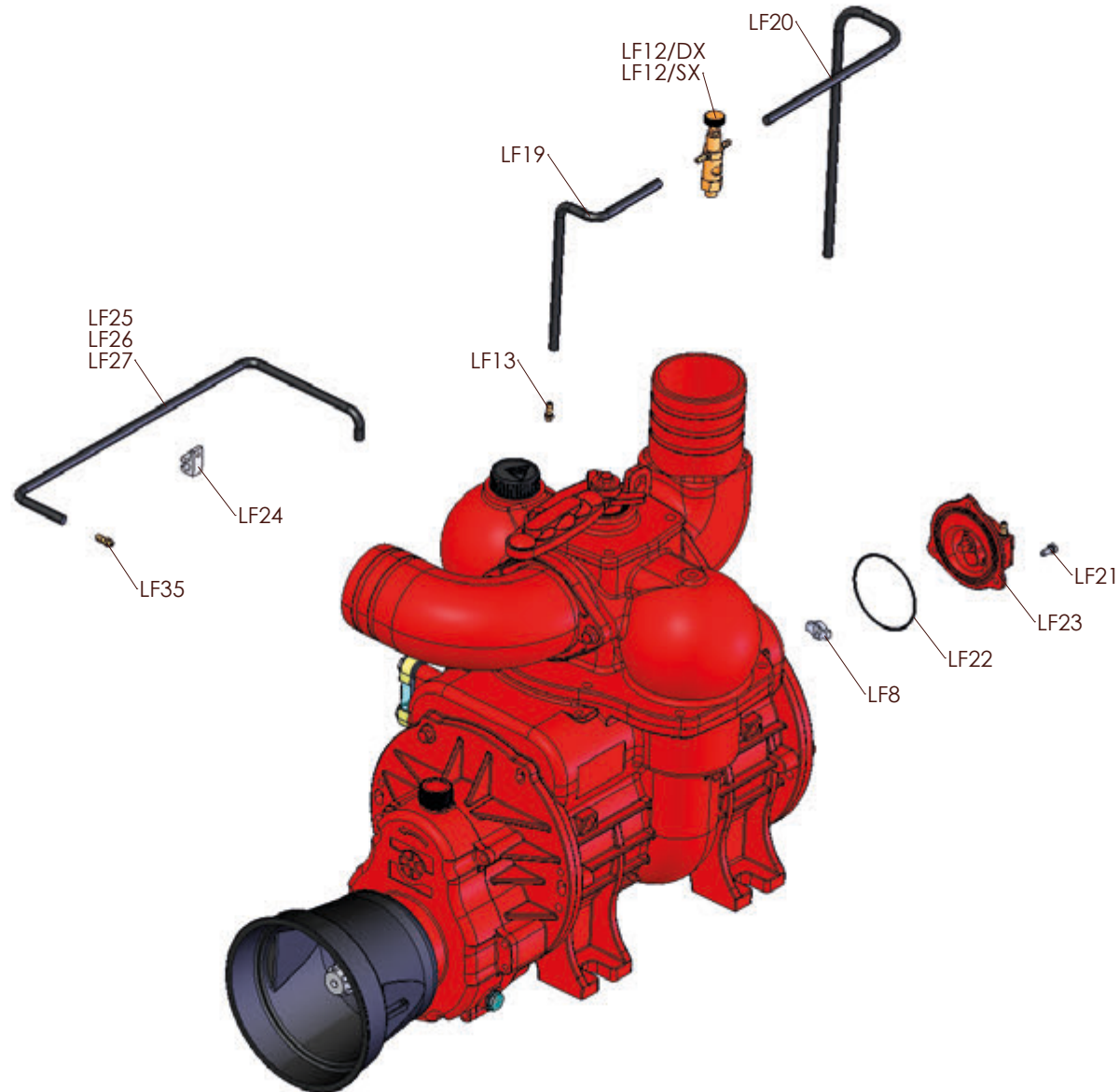



Battioni®
Pagani

Automatic lubrication MEC 9000-11000-13500

Rel. 0 del 15.01.2018

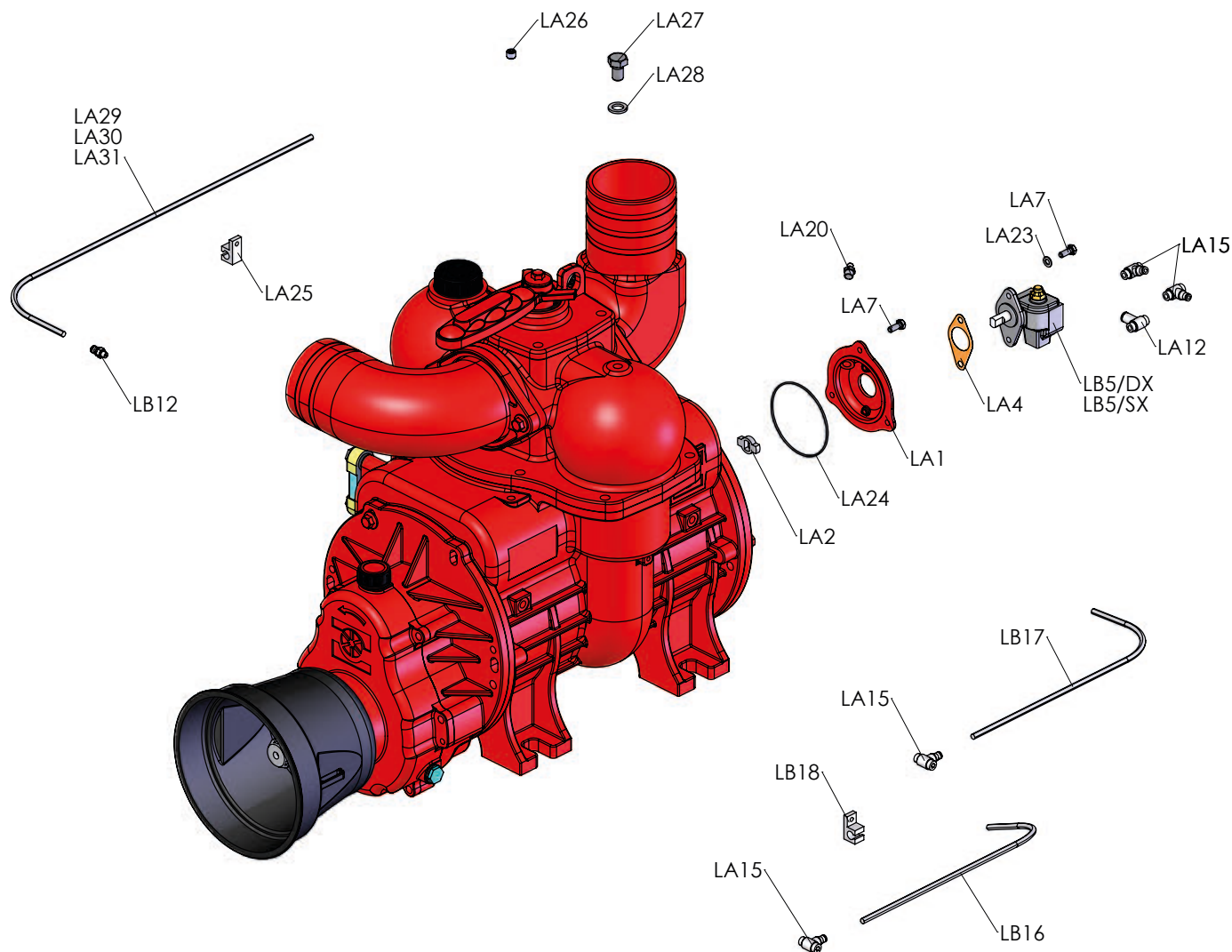



MEC 9000-11000-13500 L.F. whit side oil tank

Rel. 0 del 15.01.2018

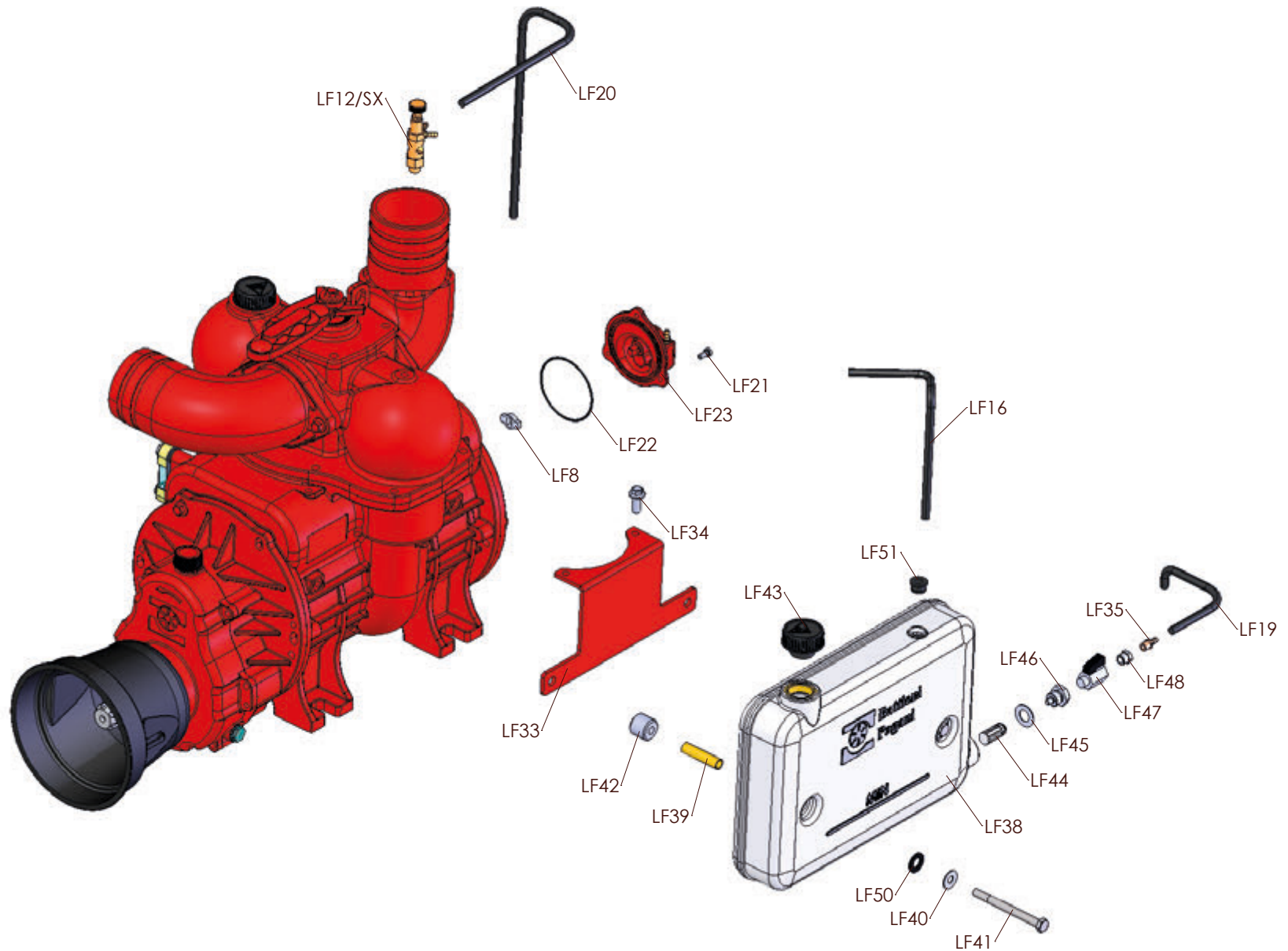



Battioni®
Pagani

MEC 9000-11000-13500 L.A. with side oil tank

Rel. 0 del 15.01.2018

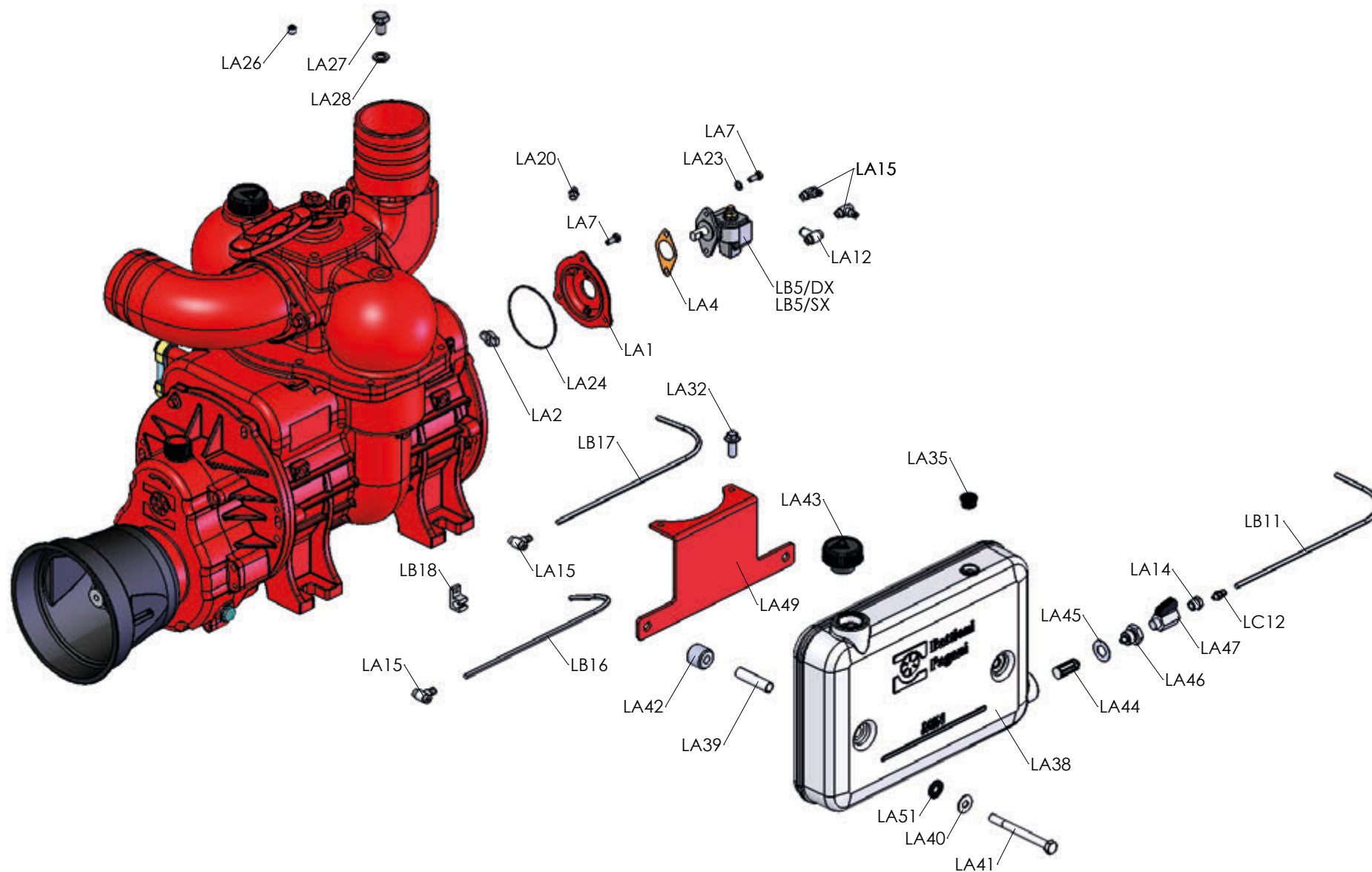



MEC LUBRICATION SYSTEM

<i>Articolo</i> (Article)	<i>Codice</i> (Code)	<i>Descrizione</i>	<i>(Description)</i>	<i>Q.ty</i>	<i>Um</i>
LA1	4010601022	COPERCHIO POSTERIORE POMPA OLIO MEC LA	OIL PUMP SUPPORT BACK COVER - MEC L.A.	1	pcs
LA2	4010006002	GIUNTO DI COLLEGAMENTO L.F.	CONNECTOR JOINT - L.F.	1	pcs
LA4	4030108011	GUARN. POMPA OLIO L.A.	OIL PUMP GASKET - L.A.	1	pcs
LA5/D	5080200033	POMPA LA 1 MAND. AL DX IIS	OIL PUMP - LA 1 WAYS AL DX IIS	1	pcs
LA5/S	5080200034	POMPA LA 1 MAND. AL SX IIS	OIL PUMP - LA 1 WAYS AL SX IIS	1	pcs
LA7	5050107005	VITE M 6X16 TE	SCREW - M 6X16 TE	5	pcs
LA11	5080105002	TUBO LUBRIFICAZIONE D 4X6 - RILSAN	SUCTION HOSE - D 4X6 RILSAN	0,24	m
LA12	5040303007	RACCORDO D 1/8"X6X90° RILSAN	CONNECTOR - D 1/8"X6X90° RILSAN	2	pcs
LC12	5040303027	RACCORDO DRITTO D 1/8"X6 RILSAN - F.CON.	STRAIGHT CONNECTOR - D 1/8"X6 RILSAN	1	pcs
LA13	5080105001	TUBO LUBRIFICAZIONE D 2X4 - RILSAN	LUBRICATION HOSE - D 2X4 RILSAN	0,47	m
LA14	5040407001	RIDUZIONE D 1/4"X1/8" GAS	REDUCTION - D 1/4"X1/8" GAS	1	pcs
LA15	5040303008	RACCORDO D 1/8"X4X90° RILSAN	CONNECTOR - D 1/8"X4X90° RILSAN	4	pcs
LA20	5050812001	INGRASSATORE M 10X1	LUBRICATOR - M 10X1	1	pcs
LA22	4030108005	GUARN. COPERCHIO POSTERIORE MEC 2-8000	BACK COVER GASKET - MEC 2-8000	1	pcs
LA23	5050207002	RONDELLA D 6	SMOOTH WASHER - D 6	5	pcs



MEC LUBRICATION SYSTEM

<i>Articolo</i> (Article)	<i>Codice</i> (Code)	<i>Descrizione</i>	<i>(Description)</i>	<i>Q.ty</i>	<i>Um</i>
LA24	5030210028	ANELLO TENUTA OR 2337 POMPA LF	SEAL RING - OR 86824 LF PUMP	1	pcs
LA25	5080004004	FASCETTA STRINGITUBO D 6 LA	HOSE CLAMP - D 6 LA	1	pcs
LA26	5050903001	TAPPO M 10x1 - DIN 906	PLUG M 10x1 DIN 906	1	pcs
LA27	5050906001	TAPPO D 1/4" GAS	PLUG - D 1/4" GAS	1	pcs
LA28	5050202003	RONDELLA D 1/4" GAS ALLUMINIO	ALUMINIUM WASHER - D 1/4" GAS	1	pcs
LA29	5080105003	TUBO LUBRIFICAZIONE D4X6 TEFLON-MEC9000	SUCTION HOSE - D 4X6 TEFLON - MEC9000	0,5	m
LA30	5080105003	TUBO LUBRIFICAZIONE D4X6 TEFLON-MEC11000	SUCTION HOSE - D 4X6 TEFLON - MEC11000	0,55	m
LA31	5080105003	TUBO LUBRIFICAZIONE D4X6 TEFLON-MEC13500	SUCTION HOSE - D 4X6 TEFLON - MEC13500	0,6	m
LA32	5050107108	VITE M 8X25 TEF - FL/ZIGR 8.8 -	SCREW - M 8X25 TEF - FL/ZIGR 8.8	2	pcs
LA35	4060310001	PASSATUBO CHIUSO	CLOSED RUBBER FITTING	1	pcs
LA38	4011406012	SERBATOIO OLIO STAMPATO	OIL TANK THERMOFORMED	1	pcs
LA39	4011707113	INSERTO OTTONE SERBATOIO PLASTICA	INSERT BRASS PLASTIC OIL TANK	2	pcs
LA40	5050207024	RONDELLA D 10 ZINCATA	GALVANIZED FLAT WASHER - D 10	2	pcs
LA41	5050107025	VITE M 10X100 TE	SCREW - M 10X100 TE	2	pcs
LA42	4011707112	DISTANZIALE SERBATOIO PLASTICA	SPACER FOR PLASTIC TANK	2	pcs



MEC LUBRICATION SYSTEM

<i>Articolo</i> (Article)	<i>Codice</i> (Code)	<i>Descrizione</i>	<i>(Description)</i>	<i>Q.ty</i>	<i>Um</i>
LA43	5060605014	TAPPO CARICO OLIO D 1" GAS	CHARGE OIL PLUG - D 1" GAS	1	pcs
LA44	5080005001	FILTRO OLIO WPT LA	OIL FILTER - WPT LA	1	pcs
LA45	5050202004	RONDELLA D 1/2" GAS ALLUMINIO	ALUMINIUM WASHER - D 1/2" GAS	1	pcs
LA46	4040407001	RIDUZIONE PORTAFILTRO WPT LA	FILTER REDUCTION - WPT LA	1	pcs
LA47	5040200001	RUBINETTO SERBATOIO OLIO D 1/4" GAS	OIL TANK DRAIN COCK - D 1/4" GAS	1	pcs
LA48	5040303015	RACCORDO DRITTO D 1/4"X6 RILSAN	CONNECTOR - R1 1/4"X6	1	pcs
LA49	4010007061	SUPPORTO SERBATOIO PLASTICA MEC9-13500	SIDE PLASTIC TANK SUPPORT - MEC 9-13500	1	pcs
LA50	5050903003	TAPPO D. 1/8" - DIN 906	PLUG - D 1/8" DIN 906	1	pcs
LA51	4060310005	RONDELLA IN GOMMA	RUBBER WASHER	2	pcs
LB5/DX	5080200036	POMPA LA 2 MAND. AL DX IIS	OIL PUMP - LA 2 WAYS AL DX IIS	1	pcs
LB5/SX	5080200038	POMPA LA 2 MAND. AL SX IIS	OIL PUMP - LA 2 WAYS AL SX IIS	1	pcs
LB11	5080105002	TUBO LUBRIFICAZIONE D 4X6 - RILSAN	SUCTION HOSE - D 4X6 RILSAN	0,26	m
LB12	5040303011	RACCORDO DRITTO D 1/8"X6 RILSAN	STRAIGHT CONNECTOR - D 1/8"X6 RILSAN	1	pcs
LB16	5080105001	TUBO LUBRIFICAZIONE D 2X4 - RILSAN	LUBRICATION HOSE - D 2X4 RILSAN	0,69	m
LB17	5080105001	TUBO LUBRIFICAZIONE D 2X4 - RILSAN	LUBRICATION HOSE - D 2X4 RILSAN	0,29	m



MEC LUBRICATION SYSTEM

<i>Articolo</i> (Article)	<i>Codice</i> (Code)	<i>Descrizione</i>	<i>(Description)</i>	<i>Q.ty</i>	<i>Um</i>
LB18	5080004002	FASCETTA STRINGITUBO D 4 LA	HOSE CLAMP - D 4	1	pcs
LC1	4010606017	COPERCHIO POSTERIORE MEC 1000-1600 LA	BACK COVER - MEC 1000-1600 LA	1	pcs
LC12	5040303027	RACCORDO DRITTO D 1/8"X6 RILSAN - F.CON.	STRAIGHT CONNECTOR - D 1/8"X6 RILSAN C.T	1	pcs
LC13	5080105001	TUBO LUBRIFICAZIONE D 2X4 - RILSAN	LUBRICATION HOSE - D 2X4	0,42	m
LC22	4030108002	GUARN. COPERCHIO POSTERIORE MEC 1-1600	BACK COVER GASKET - MEC 1-1600	1	pcs
LF8	4010006002	GIUNTO DI COLLEGAMENTO L.F.	CONNECTOR JOINT - L.F.	1	pcs
LF12/DX	5040200003	RUBINETTO REGOLATORE OLIO 2 VIE X 180°	DRAIN COCK - 2 WAYS X 180°	1	pcs
LF12/SX	5040200007	RUBINETTO REGOLATORE OLIO 2 VIE X 60°	DRAIN COCK - 2 WAYS X 60°	1	pcs
LF13	5040303029	RACCORDO PORTATUBO 1/8" GAS	CONNECTOR 1/8" GAS	2	pcs
LF14	5080110002	TUBO IN GOMMA D 5X11	RUBBER HOSE - D 5X11	0,17	m
LF16	5080110002	TUBO IN GOMMA D 5X11	RUBBER HOSE - D 5X11	0,4	m
LF19	5080110002	TUBO IN GOMMA D 5X11	RUBBER HOSE - D 5X11	0,21	m
LF20	5080110002	TUBO IN GOMMA D 5X11	RUBBER HOSE - D 5X11	0,47	m
LF21	5050107005	VITE M 6X16 TE	SCREW - M 6X16 TE	3	pcs
LF22	5030210028	ANELLO TENUTA OR 2337 POMPA LF	SEAL RING - OR 2337 LF PUMP	1	pcs



MEC LUBRICATION SYSTEM

<i>Articolo</i> (Article)	<i>Codice</i> (Code)	<i>Descrizione</i>	<i>(Description)</i>	<i>Q.ty</i>	<i>Um</i>
LF23	6080200001	POMPA LF MEC 2-8000 COMPLETA	PUMP - LF MEC 2-8000 FULL	1	pcs
LF24	5080004003	FASCETTA STRINGITUBO D 10 LF	HOSE CLAMP - D 10 LF	1	pcs
LF25	5080110002	TUBO DI ASPIRAZIONE 5X11 - MEC9000	RUBBER HOSE 5X11 - MEC9000	0,5	m
LF26	5080110002	TUBO DI ASPIRAZIONE 5X11 - MEC11000	RUBBER HOSE 5X11 - MEC11000	0,55	m
LF27	5080110002	TUBO DI ASPIRAZIONE 5X11 - MEC13500	RUBBER HOSE 5X11 - MEC13500	0,6	m
LF29	5060605007	TAPPO CARICO OLIO D 1"1/4 GAS	OIL PLUG - D 1"1/4 GAS	1	pcs
LF32	5060105003	LIVELLO OLIO COMPLETO SLV 127	COMPLETE OIL LEVEL - SLV 127	1	pcs
LF33	4011001074	SUPPORTO SERBATOIO LATER. MEC 9-11-13500	SIDE TANK SUPPORT - MEC 9-11-13500	1	pcs
LF34	5050107108	VITE M 8X25 TEF - FL/ZIGR 8.8 -	SCREW - M 8X25 TEF - FL/ZIGR 8.8	2	pcs
LF35	5040303029	RACCORDO PORTATUBO 1/8" GAS LF	CONNECTOR - D 1/8" GAS LF	2	pcs
LF38	4011406012	SERBATOIO OLIO STAMPATO	OIL TANK THERMOFORMED	1	pcs
LF39	4011707113	INSERTO OTTONE SERBATOIO PLASTICA	INSERT BRASS PLASTIC OIL TANK	2	pcs
LF40	5050207024	RONDELLA D 10 ZINCATA	GALVANIZED FLAT WASHER - D 10	2	pcs
LF41	5050107025	VITE M 10X100 TE	SCREW - M 10X100 TE	2	pcs
LF42	4011707112	DISTANZIALE SERBATOIO PLASTICA	SPACER FOR PLASTIC TANK	2	pcs



MEC LUBRICATION SYSTEM

<i>Articolo</i> (Article)	<i>Codice</i> (Code)	<i>Descrizione</i>	<i>(Description)</i>	<i>Q.ty</i>	<i>Um</i>
LF43	5060605014	TAPPO CARICO OLIO D 1" GAS	CHARGE OIL PLUG - D 1" GAS	1	pcs
LF44	5080005001	FILTRO OLIO WPT LA	OIL FILTER - WPT LA	1	pcs
LF45	5050202004	RONDELLA D 1/2" GAS ALLUMINIO	ALUMINIUM WASHER - D 1/2" GAS	1	pcs
LF46	4040407001	RIDUZIONE PORTAFILTRO WPT LA	FILTER REDUCTION - WPT LA	1	pcs
LF47	5040200001	RUBINETTO SERBATOIO OLIO D 1/4" GAS	OIL TANK DRAIN COCK - D 1/4" GAS	1	pcs
LF48	5040407001	RIDUZIONE D 1/4"X1/8" GAS	REDUCTION - D 1/4"X1/8" GAS	1	pcs
LF49	4010007061	SUPPORTO SERBATOIO PLASTICA MEC9-13500	SIDE PLASTIC TANK SUPPORT - MEC 9-13500	1	pcs
LF50	4060310005	RONDELLA IN GOMMA	RUBBER WASHER	2	pcs
LF51	4060310001	PASSATUBO CON FORO Ø 10	Ø 10 RUBBER FITTING	1	pcs



Battioni®
Pagani

Setting the pace since 1953

0	15.01.2018	1° EMISSIONE	PROG	R DT	AM
REV.	DATA	MOTIVO	PREPARATO	APPROVATO	AUTORIZZATO



Battioni®
Pagani

Setting the pace since 1953

Via Cav. Enzo Ferrari, 2
43058 Ramoscello di Sorbolo (PR) - Italy

Ph. +39 0521 663203

Fax +39 0521 663206



www.bapag.it
info@bapag.it



Battioni®
Pagani

Setting the pace since 1953

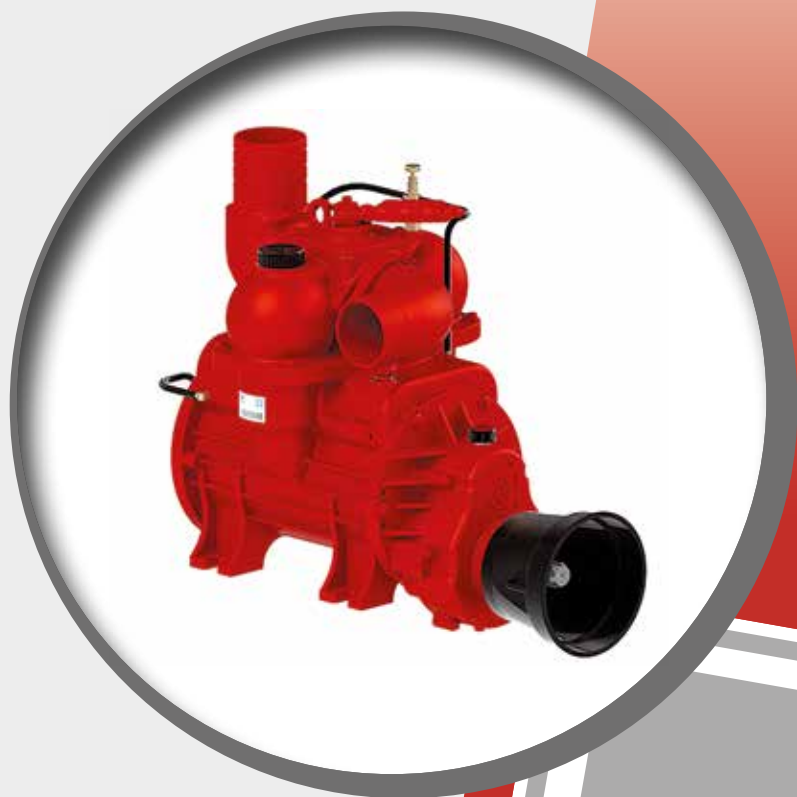

Technical Catalogue
Catalogo Tecnico
Technischer Katalog

2020
MEC

1000 - 1600 - 2000 - 3000
4000 - 5000 - 6500 - 8000
9000 - 11000 - 13500



www.bapag.it

rev. 2 del 15/10/2020



Battioni®
Pagani

Setting the pace since 1953

Predisposition for overpressure valve

Predisposizione per valvola di sovrappressione
Vorbereitung für Überdruckventil

Non-return check valve as standard

Valvola di non ritorno di serie
Kontrollventil als Serie



**Forced lubrication pump as standard
(automatic lubrication on request)**

Pompa di lubrificazione forzata di serie
(lubrificazione automatica a richiesta)
Druckschmierung als Serie (Automatische
Schmierung auf Anfrage)



Long Life blades on request

Palette Long Life resistenti al calore a richiesta
Auf Anfrage hitzebeständigen Lamellen Long Life

**High wearing resistance thanks to cast-iron
with high hardness**

Elevata resistenza ad usura grazie a ghisa ad
alta durezza

Hohe Festigkeit zu Abnutzung für
Gußeisen mit hohe Härte



**AIR COOLED
ROTARY VANES
VACUUM/PRESSURE
PUMP**



Selector vacuum - pressure

Selettore Vuoto - Pressione
Wähler von Vakuum/Druck

Blades inspection hole

Foro ispezione palette
Bohrung für Lamellen Prüfung



VERSIONS



MEC - M



MEC - P



MEC - D



MEC - H



MEC - HM

MEC the legend





MEC 1000/1600 – Light and compact design

The reliability and strength of the MEC is the result of continuous design and manufacturing improvements accomplished during 40 years of deployments. Its light and compact design made MEC 1000/1600 the best vacuum pump for portable sanitation services and small vacuum tank for liquid applications.



STANDARD FEATURES

- 4-ways valve, non-return check valve.
- Available hoses connections: Ø 27 mm / Ø 45 mm / G 1" / G 1" 1/4
- Thread for Overpressure valve: Not available

VERSIONS

CCW as standard



Version M
Splined shaft
1"3/8 - Z6 ISO 500

CCW on request CW as standard



Version P
Smooth Cylindrical shaft
Ø 22, lenght 48 mm
Parallel key UNI 6604

CW as standard



Version H
MEC 1000: Group 2 21.14 cc/rev - Pmax 200 bar - In G 1/2" - Out G 3/4"
MEC 1600: Group 2 21.14 cc/rev - Pmax 200 bar - In G 1/2" - Out G 3/4"
MEC 1000: Group 2 40 cc/rev - Pmax 175 bar - In G 1/2" - Out G 1/2"
MEC 1600: Group 2 40 cc/rev - Pmax 175 bar - In G 1/2" - Out G 1/2"

TECHNICAL DATA

	Geometrical capacity			Max rpm		Max abs pressure Bar (PSI)	Max vacuum % (inHg)	Max continuous vacuum % (inHg)	Power at max vacuum kW (HP)	Weight kg		
	m³/h	l/min	cfm	M	P/H					M	P	H
MEC 1000	75,6	1260	45	600	1400	2,5 (36)	89% (26,3")	60% (18")	3,5 (4,7)	40	34	48
MEC 1600	118,8	1980	70	600	1400	2,5 (36)	89% (26,3")	60% (18")	4,5 (6)	48	42	56

OPTIONALS



Long Life Blades



Automatic Lubrication
Single lubrication point



Revolving Elbow
Ø 45 mm



Battioni Pagani Vacuum Pump Oil 5 lt.
Code 5070200100



Battioni Pagani Flushing Fluid 5 lt.
Code 5070200102



Flushing Kit
Code 6080200325



Pump Controller



Pump Active Controller



Customized Painting



ACCESSORIES



01 **Overpressure Safety Valve - 1"1/4**
Code 5100200009
Setting range:
+0,3 bar / +1,5 bar
Working temperature:
-20°C / +90°C
Thread: G 1"1/4
Weight: 0,94 kg



02 **Vacuum Relief Valve 1"1/2**
Code 5100200012
Setting range:
-0,3 bar / -0,8 bar
Working temperature:
-20°C / +90°C
Thread: G 1"1/2
Weight: 0,65 kg

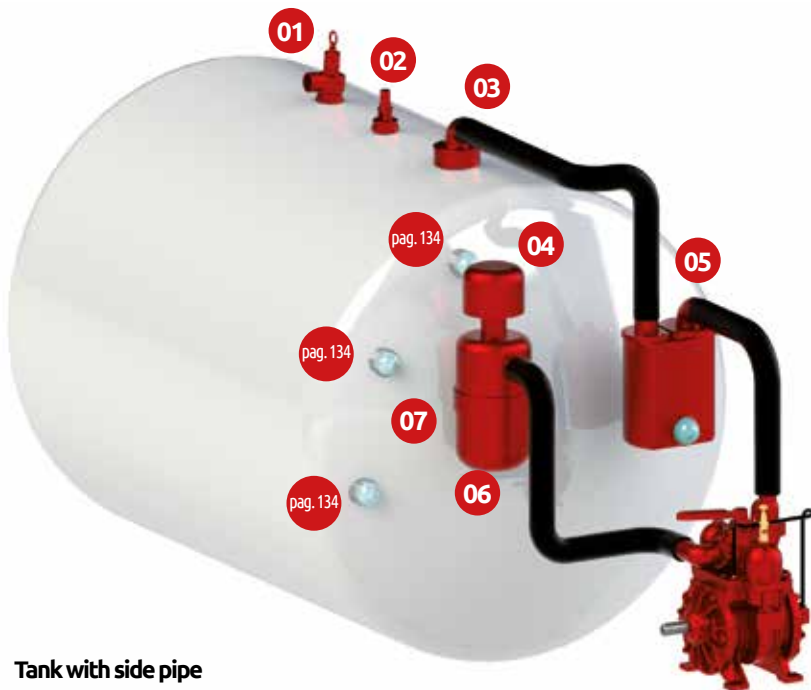

Tank with side pipe



06 **Filter - Silencer**
Code 5090000110
Hose connection: Ø 45 mm
Weight: 2,5 kg



04 **Rain Cap**
Code 5090000111
For Filter/silencer only Ø 45 mm



07 **Sliding Support**
Code 5090000138 (Ø 165)
(Silencer Code 5090000110)



03 **Primary Overflow Valve - Single Rubber Ball**
Code 6100200006 - Ø45
Iron ring to be welded
Weight: 4,5 kg



05 **Secondary Valve - Single Rubber Ball**
Code 6100200003 - Ø45
Weight: 17,5 kg



05A **Discharge Valve - 3/4"**
Code 5040200006
To be fitted on Secondary valve



05B **Gauge - Ø 80 mm Axial Connection**
Code 5101700007
To be fitted on Secondary valve



MEC

2000 - 3000 - 4000



Battioni®
Pagani

Setting the pace since 1953

MEC 2000 / 3000 / 4000 – Simple and practical design

The reliability and strength of the MEC is the result of continuous design and manufacturing improvements accomplished during 40 years of deployments. It's simple and practical design made the MEC pumps the product of reference for agricultural and municipalities septic applications.



STANDARD FEATURES

- Forced lubrication, 4-ways valve, non-return check valve
- Available hoses connections: Ø 45 mm / Ø 60 mm / G 2"
- Thread for Overpressure valve: G 1 1/4

VERSIONS

CCW as standard	CCW on request	CW as standard	CCW as standard	CCW as standard	CW as standard
Version M Splined shaft 1 3/8 - Z6 ISO 500	Version P Smooth Cylindrical shaft Ø 30, lenght 50 mm Parallel key UNI 6604	Version D Splined shaft 1 3/8 - Z6 ISO 500	Version HM 100 cc/rev Pmax 175 bar In G 1/2" - Out G 1/2"	Version H MEC 2000: Group 3 26.7 cc/rev - Pmax 280 bar - In G 1" - Out G 3/4" MEC 3000: Group 3 26.7 cc/rev - Pmax 280 bar - In G 1" - Out G 3/4" MEC 4000: Group 3.5 43.98 cc/rev - Pmax 250 bar - In G 1" - Out G 1"	

TECHNICAL DATA

	Geometrical capacity			Max rpm		Max abs pressure Bar/PSI	Max vacuum % (inHg)	Max continuous vacuum % (inHg)	Power at max vacuum kW (HP)	Weight kg				
	m³/h	l/min	cfm	M/HM	P/D/H					M	P	D	H	HM
MEC 2000	165	2750	97	600	1400	2,5 (36)	91% (27,0")	60% (18")	5,5 (7,3)	75	65	65	81	77
MEC 3000	216	3600	127	600	1400	2,5 (36)	92% (27,2")	60% (18")	7 (9,4)	86	75	77	92	89
MEC 4000	261	4350	154	600	1400	2,5 (36)	94% (28,0")	60% (18")	9 (12,6)	97	85	90	116	102

OPTIONALS

Long Life Blades	Automatic Lubrication Single lubrication points	Side Outlet With two revolving elbows	Double Outlet Ø 60 mm	Revolving Elbow Ø 45 mm Ø 51 mm Ø 60 mm	Kit Vacuum Relief Valve For Revolving Elbow Code 6080200390
Hydraulic Changeover Code 6080200217	Pneumatic Revolving Changeover Code 6080200160	Kit Valves and manometer tree 1" 1/4 Code 6080200391	Kit Overpressure 1" 1/4 safety valve for Revolving Elbow Code 6080200396	Kit Valves and manometer tree U.L. Code 6080200488	Kit Aluminum final air filter 500 Self-Cleaning Code 6080200507



OPTIONALS



Flushing Kit
Code 6080200325



Battioni Pagani Vacuum Pump Oil 5 lt.
Code 5070200100



Battioni Pagani Flushing Fluid 5 lt.
Code 5070200102



Pump Controller



Pump Active Controller



Customized Painting

Air cooled - Rotary Vanes Vacuum/Pressure pumps

ACCESSORIES



01 Vacuum Relief Valve 1 1/2
Code 5100200012
Setting range:
-0,3 bar / -0,8 bar
Working temperature:
-20°C / +90°C
Thread: G 1 1/2
Weight: 0,65 kg



02 Overpressure Safety Valve - 1 1/4
Code 5100200009
Setting range:
+0,3 bar / +1,5 bar
Working temperature:
-20°C / +90°C
Thread: G 1 1/4
Weight: 0,94 kg



06 Filter - Silencer
Code 5090000110 - Ø 45
MEC 2000
Code 5090000083 - Ø 60
MEC 3000 - 4000
Weight: 3,9 kg



Tank with side pipe



04A Rain Cap
Code 5090000111 - Ø 45
For Filter/silencer only
MEC 2000
Code 5090000060 - Ø 60
For Filter/silencer only
MEC 3000 - 4000



04B Pre-Filter
Code 5090000045 - Ø 60
For Filter/silencer only
MEC 3000 - 4000



07 Sliding Support
Code 5090000138 (Ø 165)
(Silencer Code 5090000110)
Code 5090000139 (Ø 187)
(Silencer Code 5090000083)



03 Primary Overflow Valve - Single Rubber Ball
Code 6100200006 - Ø 45
Code 6100200007 - Ø 60
Iron ring to be welded
Weight: 4,5 kg



05 Secondary Valve - Single Rubber Ball
Code 6100200003 - Ø 45
Code 6100200004 - Ø 60
Weight: 17,5 kg



05A Discharge Valve - 3/4"
Code 5040200006
To be fitted on Secondary valve



05B Gauge - Ø 80 mm Axial Connection
Code 5101700007
To be fitted on Secondary valve



MEC

5000 - 6500 - 8000



Battioni®
Pagani

Setting the pace since 1953

MEC 5000 / 6500 / 8000 – The Legend

More than 500.000 MEC pumps have been put in operation to empty cesspits and transport slurry in agricultural and industrial applications. The reliability and strength of the MEC is the result of continuous design and manufacturing improvements accomplished during 40 years of deployments.



STANDARD FEATURES

- Forced lubrication, 4-ways valve, check valve
- Thread for Overpressure valve: G 1"1/2
- Available hoses connections: Ø 60 mm / Ø 76 mm (3") / Ø 80 mm

VERSIONS

CCW as standard	CCW on request	CW as standard	CCW as standard	CCW as standard	CW as standard
Version M Splined shaft 1"3/8 - Z6 ISO 500	Version P Smooth Cylindrical shaft Ø 32, lenght 70 mm Parallel key UNI 6604	Version D Splined shaft 1"3/8 - Z6 ISO 500	Version HM 100 cc/rev- Pmax 175 bar In G 1/2" - Out G 1/2"	Version H MEC 5000: Group 3.5 43.98 cc/rev - Pmax 250 bar - In G 1" - Out G 1" MEC 6500: Group 3.5 43.98 cc/rev - Pmax 250 bar - In G 1" - Out G 1" MEC 8000: Group 3.5 51.83 cc/rev - Pmax 230 bar - In G 1" - Out G 1"	

TECHNICAL DATA

	Geometrical capacity			Max rpm		Max abs pressure Bar/PSI	Max vacuum % (inHg)	Max continuous vacuum % (inHg)	Power at max vacuum kw (HP)	Weight kg				
	m³/h	l/min	cfm	M/HM	P/D/H					M	P	D	H	HM
MEC 5000	369	6150	217	600	1400	2,5 (36)	94% (28,0")	60% (18")	11 (14,7)	127	120	121	136	132
MEC 6500	420	7000	247	600	1400	2,5 (36)	94% (28,0")	60% (18")	12,5 (16,7)	142	129	130	154	150
MEC 8000	486	8100	286	600	1400	2,5 (36)	94% (28,0")	60% (18")	16 (21,4)	157	140	141	174	162

OPTIONALS

Long Life Blades	Automatic Lubrication MEC 5000: Single lubrication points MEC 6500-8000: Double lubrication points	Side Outlet With two revolving elbows	Double Outlet Ø 60 mm	Revolving Elbow Ø 60 mm / Ø 76 mm (3") / Ø 80 mm	Kit Aluminum final air filter 500 Self-Cleaning Code 6080200363
Hydraulic Changeover Code 6080200175	Hydraulic Revolving Changeover Code 5090000073	Pneumatic Revolving Changeover Code 6080200114	Pneumatic Revolving Changeover - 3 Positions Code 6080200292	Kit Valves and manometer tree 1" 1/2 Code 6080200392	Kit Vacuum Relief Valve For Revolving Elbow Code 6080200486

OPTIONALS



Extra Side Tank
Code 6080200418 (LA)
Code 6080200417 (LF)



Flushing Kit
Code 6080200325



Battioni Pagani Vacuum Pump Oil 5 lt.
Code 5070200100



Battioni Pagani Flushing Fluid 5 lt.
Code 5070200102

MEC

5000 - 6500 - 8000



Pump Controller



Pump Active Controller

Air cooled - Rotary Vanes Vacuum/Pressure pumps

ACCESSORIES



01 Vacuum Relief Valve 1 1/2
Code 5100200012
Setting range:
-0,3 bar / -0,8 bar
Working temperature:
-20°C / +90°C
Thread: G 1 1/2
Weight: 0,65 kg



02 Overpressure Safety Valve - 1 1/2
Code 5100200010
Setting range:
+0,3 bar / +1,5 bar
Working temperature:
-20°C / +90°C
Thread: G 1 1/2
Weight: 1,02 kg



06 Filter - Silencer
Code 5090000083-Ø 60
MEC 5000
Code 5090000044-Ø 80
MEC 6500/8000
Weight: 7 kg (9.9 lb)



04A Rain Cap
Code 5090000060-Ø 60
MEC 5000
Code 5090000061-Ø 80
MEC 6500/8000
For Filter/silencer only



04B Pre-Filter
Code 5090000045-Ø 60
MEC 5000
Code 5090000046-Ø 80
MEC 6500/8000
For Filter/silencer only



07 Sliding Support
Code 5090000139 (Ø 187)
(Silencer Code 5090000083)



Tank with side pipe



03 Primary Overflow Valve - Single Rubber Ball
Code 6100200007 - Ø 60
Code 6100200008 - Ø 80
Iron ring to be welded
Weight: 4,7/9,6 kg



05 Secondary Valve - Single Rubber Ball
Code 6100200004 - Ø 60
Code 6100200005 - Ø 80
Weight: 18,5/20,5 kg



05A Discharge Valve - 3/4"
Code 5040200006
To be fitted on Secondary valve



05B Gauge - Ø 80 mm Axial Connection
Code 5101700007
To be fitted on Secondary valve



**Battioni®
Pagani**

Setting the pace since 1953

Kit Aluminum Final Air Filter

Kit filtro aria alluminio
Saugfilter Satz

Predisposition for overpressure valve

Predisposizione per valvola di sovrappressione
Vorbereitung für Überdruckventil

Selector vacuum - pressure

Selettore Vuoto - Pressione
Wähler von Vakuum/Druck



Temperature indicator

Rilevatore di temperatura
Temperaturdedektor

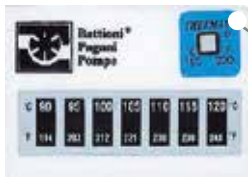

160° C Irreversible indicator

Indicatore Irreversibile 160° C
irreversibel Anzeiger 160°C

Forced lubrication pump as standard (automatic lubrication on request)

Pompa di lubrificazione forzata di serie (lubrificazione automatica a richiesta)
Druckschmierung als Serie (Automatische Schmierung auf Anfrage)

Long Life blades as standard

Palette "long life" resistenti al calore di serie
Hitzebeständigen Lamellen aus Spezialmaterial als Serie



**AIR COOLED
ROTARY VANES
VACUUM/PRESSURE
PUMP**

High wearing resistance thanks to cast-iron with high hardness

Elevata resistenza ad usura grazie a ghisa ad alta durezza

Hohe Festigkeit zu Abnutzung für Gußeisen mit hohe Härte

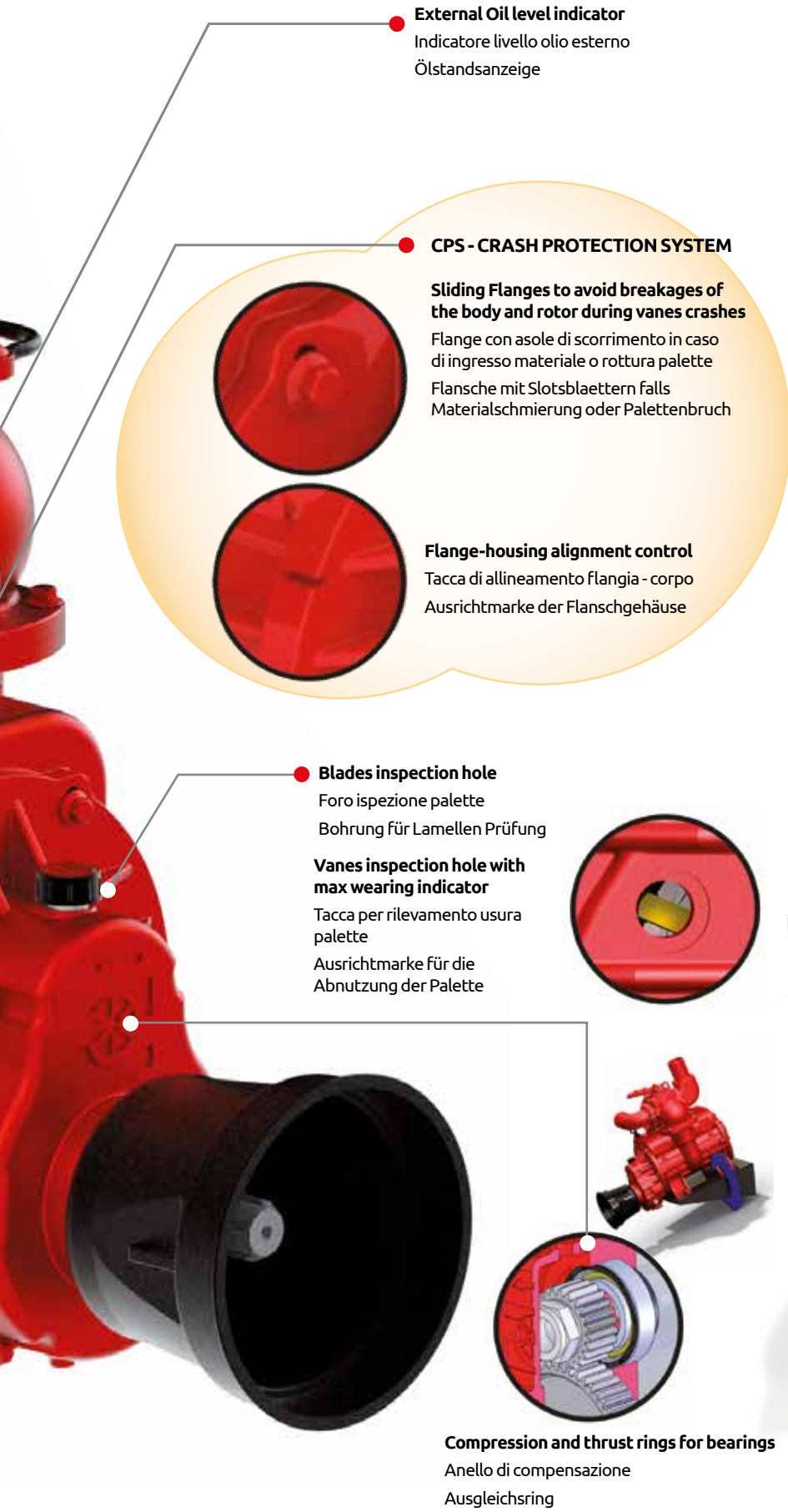

● **External Oil level indicator**
Indicatore livello olio esterno
Ölstandsanzeige

● **CPS - CRASH PROTECTION SYSTEM**
Sliding Flanges to avoid breakages of the body and rotor during vanes crashes
Flange con asole di scorrimento in caso di ingresso materiale o rottura palette
Flansche mit Slotsblättern falls Materialschmierung oder Palettenbruch



● **Flange-housing alignment control**
Tacca di allineamento flangia - corpo
Ausrichtmarke der Flanschgehäuse

● **Blades inspection hole**
Foro ispezione palette
Bohrung für Lamellen Prüfung

● **Vaness inspection hole with max wearing indicator**
Tacca per rilevamento usura palette
Ausrichtmarke für die Abnutzung der Palette

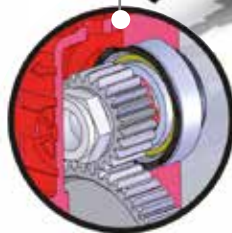

● **Compression and thrust rings for bearings**
Anello di compensazione
Ausgleichsring

VERSIONS



MEC - M/MA



MEC - P



MEC - D



MEC - H



MEC - HM

Discover the CPS - Crash Protection System



The picture is only for informative purpose.
See the table on page 89 for the complete list of the available optionals.



MEC II

9000 - 11000 - 13500

MEC II – The Legend continues

Designed in cooperation with SPRInT, the Team of Engineering and Research of the Department of Industrial Engineering at the University of Parma, the MEC II pump represents a technology breakthrough resulted from a major joint effort in product **development and innovative design processes**. The MEC II features the **Crash Protection System**: a sliding flanges protection mechanism that prevents the housing or rotor to break of in case of vanes crash. The pump is easily repairable inexpensively in field.



STANDARD FEATURES

- Long Life Blades, Crash Protection System, forced lubrication, external oil level indicator, side outlets, exhaust elbow, 4-ways valve, check valve
- Thread for Overpressure valve: G 2"
- Available hoses connections: Ø 76 mm (3") / Ø 80 mm / Ø 100 mm (4")

VERSIONS



Version M - MA
Splined shaft
1"3/8 - Z6 ISO 500

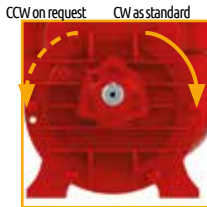

Version P
Smooth Cylindrical shaft,
Ø 32, lenght 63 mm
Parallel key UNI 6604



Version D
Splined shaft
1"3/8 - Z6 ISO 500



Version HM
MEC9000: 100 cc/rev
Pmax 175 bar - In G 1/2" - Out G 1/2"
MEC11000: 125.7 cc/rev
Pmax 175 bar - In G 1/2" - Out G 1/2"

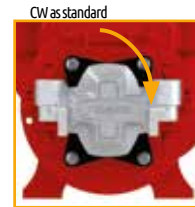

Version H
MEC 9000: Group 3.5 51.83 cc/rev
Pmax 230 bar - In G 1" - Out G 1"
MEC 11000: Group 3.5 73.82 cc/rev
Pmax 180 bar - In G 1" - Out G 1"1/4
MEC 13500: Group 4 86.56 cc/rev
Pmax 280 bar - In G 1"1/4 - Out G 1"1/2

TECHNICAL DATA

	Geometrical capacity			Max rpm			Max abs pressure Bar/PSI	Max vacuum % (inHg)	Max continuous vacuum % (inHg)	Power at max vacuum kW (HP)	Weight kg				
	m³/h	l/min	cfm	M/HM	MA	P/D/H					M/MA	P	D	H	HM
MEC II 9000	541,8	9030	319	600	1000	1400	2,5 (36)	95% (28,5")	60% (18")	17 (22,8)	145	131	132	154	146
MEC II 11000	668,22	11137	393	600	1000	1400	2,5 (36)	95% (28,5")	60% (18")	21 (28,2)	160	146	147	170	161
MEC II 13500	830,7	13845	489	600	1000	1400	2,5 (36)	95% (28,5")	60% (18")	25 (33,5)	178	164	165	205	-

OPTIONALS



Automatic Lubrication
Double lubrication points



Kit Aluminum Final Air Filter 1300 Self-Cleaning
Code 6080200290



Side Outlet With Two Revolving Elbows
Ø 76/80/100



Double Outlet
Ø 80 mm



Kit Vacuum Relief Valve For Revolving Elbow
Code 6080200181



Extra Side Tank
Code 6080200304 (LA)
Code 6080200310 (LF)



Hydraulic Changeover
Code 6080200176



Hydraulic Revolving Changeover
Code 5090000078



Pneumatic Revolving Changeover
Code 6080200238



Pneumatic Revolving Changeover - 3 Positions
Code 6080200293



Battioni Pagani Vacuum Pump Oil 5 lt.
Code 5070200100



Battioni Pagani Flushing Fluid 5 lt.
Code 5070200102

OPTIONALS



Flushing Kit
Code 6080200325



Pump Controller



Pump Active Controller



Customized Painting

MEC II

9000 - 11000 - 13500



Air cooled - Rotary Vanes
Vacuum/Pressure pumps

ACCESSORIES



Vacuum Relief Valve 1 1/2"

Code 5100200012
Setting range:
-0,3 bar / -0,8 bar
Working temperature:
-20°C / +90°C
Thread: G 1 1/2"
Weight: 0,65 kg



Overpressure Safety Valve - 2"

Code 5100200011
Setting range:
+0,3 bar / +1,5 bar
Working temperature:
-20°C / +90°C
Thread: G 2"
Weight: 1,2 kg



Tank with side pipe



Filter - Silencer
Code 5090000025
MEC 9000-11000-Ø80
Code 5090000026
MEC 13500-Ø100
Hose connection:
Ø 80/100 mm
Weight: 9,5/13 kg



Rain Cap
Code 5090000061
MEC 9000-11000 - Ø 80
Code 5090000062
MEC 13500 - Ø 100
Weight: 0,4 kg



Pre-Filter
Code 5090000046
MEC 9000-11000 - Ø 80
Code 5090000047
MEC 13500 - Ø 100



Primary Overflow Valve - Two Balls
Code 6100200030-Ø76
Code 6100200025-Ø80
Code 6100200026-Ø100
Iron ring to be welded
Weight: 13,9/14,0 kg



Primary Overflow Valve - One SS Ball
Code 6100200027-Ø80SS
Code 6100200028-Ø100SS
Ball material: AISI 316
Iron ring to be welded



Secondary Valve - Two Balls
Code 6100200035-Ø76
Code 6100200021-Ø80
Code 6100200022-Ø100
Weight: 35,6 kg



Discharge Valve - 1"
Code 5040200014
To be fitted on Secondary valve



Gauge - Ø 80 mm Axial Connection
Code 5101700007
To be fitted on Secondary valve



Battioni®

Pagani

Setting the pace since 1953

**Battioni Pagani reserve the right to modify without notice the data features shown in this manual.
The reproduction, even partial of this manual is forbidden by law.**

Battioni Pagani si riserva il diritto di approntare modifiche ai dati e alle caratteristiche illustrate nel manuale.
La riproduzione, anche parziale, del presente manuale è vietata ai termini di legge.



Battioni®
Pagani

Setting the pace since 1953



Battioni Pagani Pompe S.p.A.
Via Ferrari N. 2
43058 Sorbolo Mezzani (PR) - Italy
Ph. +39 0521 663203

www.bapag.it
info@bapag.it



INTRODUCTION

The Rotary blades vacuum pumps Battioni Pagani® have been designed and constructed in compliance with EEC safety regulations and have been assessed for risks according to standard UNI EN ISO 12100:2010; in particular they are in conformity with directive 2006/42/CE and subsequent modifications and additions.

Since the design of this pump complies with the definition of a machine as contained in the Machinery Directive 2006/42/EC, the pump bears the CE mark on its identification plate. However, it must be pointed out that because of its application and the purpose for which it is supplied, which specifies that it be installed by the buyer (without motive power), Battioni Pagani® refuses any and all responsibility if the instructions in this operation and maintenance manual are not followed.

This manual contains the Declaration of CE conformity and all the instructions required by users, and by the manufacturers of plant systems, for using our products safely. As a result, the manual must always be kept near the rotary blades vacuum pump.



This danger symbol in the manual means that important safety instructions are given. This information is destined primarily for the operator whose responsibility it is not only to comply with them personally, but also to ensure compliance by other persons exposed to the connected risks.

The descriptions and illustrations in this manual are purely indicative.

The manufacturer reserves the right to make any type of change to this manual at any time.

GUARANTEE

At the moment of receiving the Rotary blades vacuum pump check that it is complete with all its parts.

Any anomalies or missing parts must be notified within 8 days of receipt of the product.

The Supplier guarantees that the product sold is free from defects and undertakes to repair or, by final decision, to replace the faulty parts only if the defects are clearly attributed to the manufacturing process or to the materials used. In any case the costs of labour, travel and transport, and any customs expenses shall be paid by the Purchaser. The vendor is not obliged to pay damages except in the case of fraud or grave offence. All parts subject to normal wear are excluded from the guarantee. The guarantee will cease to be valid if:

- the faults reported are the result of accidents or obvious carelessness or negligence on the part of the Purchaser,
- the parts have been modified, repaired or fitted by persons not authorised by the vendor,
- the failures and breakages have been caused by use that is unsuitable or heavier than that provided for by the vendor,
- the Purchaser has failed to make the payments as agreed by contract.

The Purchaser loses his/her right to the guarantee if he/she fails to report the defects to the vendor within 8 days of discovery, making an exception to article 1512 of the Italian Civil Code. The Vendor reserves the right to make changes or improvements to his/her products without being obliged to make the same changes or improvements to the units already produced and/or delivered previously. The Vendor is not responsible for accidents or for the effects of accidents to people or property due to defective materials and/or workmanship.

Thank you for choosing Battioni Pagani®.

Battioni Pagani®



OBLIGATORY SAFETY SIGNS TO BE DISPLAYED IN THE WORK PLACE AND IN THE VICINITY OF THE ROTARY BLADES VACUUM PUMP

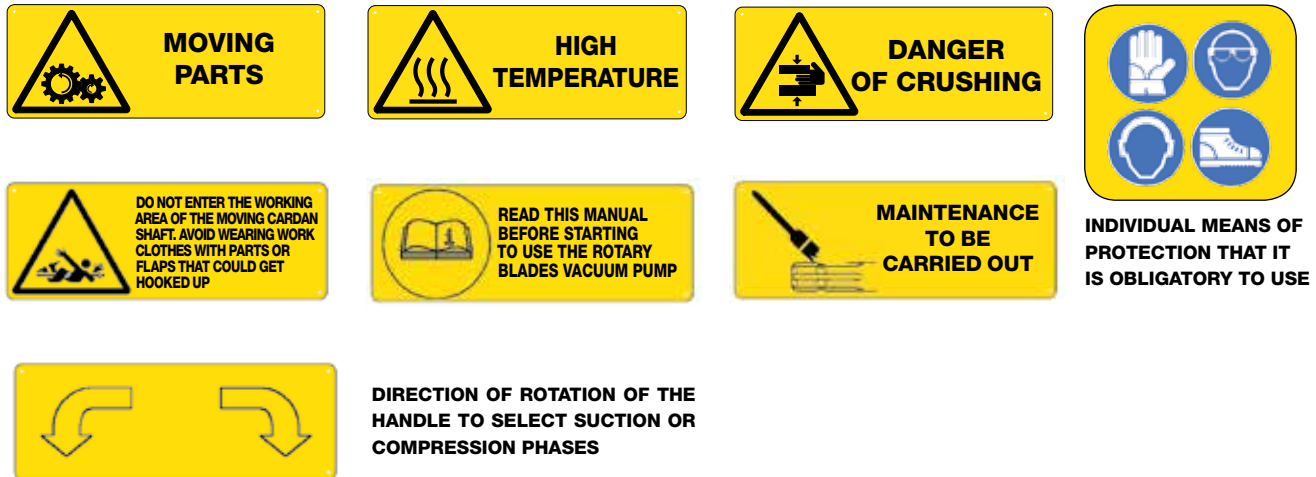

CONDITIONS AND LIMITS OF USE – LIST OF DANGERS

In the Common Market countries, the installation must comply with directive 2006/42/CE and subsequent modifications, while in the other countries it must comply with the safety regulations of the country.
This Rotary blades vacuum pump has been designed to create a vacuum or pressure inside a tank connected to it.



Under no circumstances must liquids, dust or any kind of solid matter enter the Rotary blades vacuum pump because they could cause it to break. Therefore it is necessary to equip the system with safety valves.

The use of the Rotary blades vacuum pump for any purpose other than that specified above is absolutely forbidden, not provided for by the manufacturer and therefore highly dangerous. Do not use the Rotary blades vacuum pump to handle flammable and/or explosive liquids and materials or for materials that give off flammable gasses.

Read This Manual Before Using The Suction Unit/Compressor

Do not use the rotary blades vacuum pump in a potentially explosive atmosphere.

Never remove the guards fitted on the Rotary blades vacuum pump and always check their efficiency every time the machine is used.

Any work on the machine must be carried out while it is not running.

Failure to comply with the instructions given in this manual may lead to the following dangers:

- Danger of being crushed by the Rotary blades vacuum pump mass during handling and transport;
- Danger of getting entangled in the shaft transmission parts if the necessary guards are removed;
- Heat dangers due to the temperatures that can be reached by the Rotary blades vacuum pump;
- Acoustic danger due to the noise generated and to failure to use personal means of protection;
- Danger to operator's hands during testing with suction and delivery tubes detached from the pump;
- Danger of abrasion from the shaft of the hydraulic pump support if the Rotary blades vacuum pump is operated with the hydraulic pump removed;
- Danger of projection of fluid and solid materials owing to an heavy breakage of the Rotary blades vacuum pump.



SUMMARY

INTRODUCTION.....	30
GUARANTEE.....	30
OBLIGATORY SAFETY SIGNS TO BE DISPLAYED IN THE WORK PLACE AND IN THE VICINITY OF THE	
ROTARY BLADES VACUUM PUMP.....	31
CONDITIONS AND LIMITS OF USE – LIST OF DANGERS.....	31
SUMMARY	32
GENERAL INFORMATION	34
1 - VERSIONS OF THE ROTARY BLADES VACUUM PUMP	34
1.1 IDENTIFICATION LABEL	35
INSTRUCTIONS FOR USE AND MAINTENANCE.....	36
2 - PACKAGING, STORAGE, HANDLING AND TRANSPORT.....	36
2.1 PACKAGING	36
2.2 STORAGE	36
2.3 HANDLING AND TRANSPORT.....	36
3 - ASSEMBLY, FITTING, INSTALLATION, DISASSEMBLY, RE-FITTING.....	36
3.1 INSTALLATION DRAFT.....	36
3.2 DOUBLE OUTLET INSTALLATION DRAFT.....	37
3.2.1 DIAGRAM OF INSTALLATION WITHOUT MANIFOLD ON IRRIGATION MACHINES	9
3.3 ASSEMBLY AND FITTING - INSTALLATION	37
3.4 HYDRAULIC PLAN (/H VERSION)	38
3.5 INSTRUCTIONS FOR USE AND MAINTENANCE OF HYDRAULIC MOTOR	39
3.6 DISINSTALLATON.....	41
3.7 DISASSEMBLY	41
3.7.1 Back disassembly.....	41
3.7.2 Front disassembly.....	42
3.8 RE-FITTING – RE-INSTALLATION.....	42
3.8.1 Re-fitting of the back	42
3.8.2 Re-fitting of the manifold	43
3.8.3 Re-fitting of the front.....	44
3.8.4 Correct positioning of reversing gear	44
4 - DIRECTION OF ROTATION INVERSION	45
5 - START-UP	45
5.1 OPERATION WITHOUT OVER-PRESSURE VALVE (ONLY MEC SERIES).....	45
5.2 DIRECTION OF ROTATION.....	45



6 -	SET-UP OF THE LUBRICATION SYSTEM	46
6.1	NORMAL LUBRICATION.....	46
6.2	FORCED LUBRICATION.....	46
6.3	AUTOMATIC LUBRICATION	46
6.4	OIL TO USE.....	46
	6.4.1 Absolutely, do not use following oil brands	46
	6.4.2 Gearbox oil	47
6.5	OIL LEVEL.....	47
6.6	QUANTITY OF LUBRICATION OIL.....	48
6.7	REGULATION FOR LUBRICATING OIL	49
7 -	OVERPRESSURE AND VACUUM ADJUSTMENT VALVES.....	49
8 -	TESTING AND RUNNING IN	50
8.1	TESTING.....	50
8.2	RUNNING IN	50
9 -	START, OPERATION, STOP	51
9.1	START	51
9.2	OPERATION	51
9.3	STOP	52
9.4	CONTROLS	52
9.5	PROTECTIVE DEVICES.....	52
9.6	PROTECTIVE DEVICES.....	52
9.7	INDIVIDUAL MEANS OF PROTECTION TO BE USED	52
10 -	TROUBLESHOOTING	53
11 -	MAINTENANCE, INSPECTIONS AND CHECKS, REPAIRS, TECHNICAL ASSISTANCE.....	54
11.1	CLEANING	54
	11.1.1 Washing of the body.....	54
	11.1.2 Washing of oil tank	54
	11.1.3 Washing and cleaning of valves	54
11.2	CHECKING OF VALVES.....	54
11.3	INSPECTION AND REPLACEMENT OF Blades.....	54
	11.3.1 General information on blades	54
	11.3.2 Inspection of blades.....	55
	11.3.3 Replacement of blades	55
	11.3.4 Blades dimensions.....	56
11.4	REPLACEMENT OF RUBBER BALL.....	56
11.5	REPLACEMENT OF GEARS (VERSION / M - MA / K - KA).....	56
11.6	TECHNICAL ASSISTANCE	57
11.7	REGULAR SERVICING.....	57
12 -	PUTTING OUT OF SERVICE AND DEMOLITION	57
SPARE PARTS	254	
TECHNICAL DATA	305	

GENERAL INFORMATION

1 - VERSIONS OF THE ROTARY BLADES VACUUM PUMP

The Rotary blades vacuum pump can be supplied in the following versions:

SERIE	M	MA	P	D	H	K	KA	G	GA
MEC 1000/1600	O	-	O	-	-	-	-	-	-
MEC 2/3/4000	O	-	O	O	O	-	-	O	O
MEC 5/6.5/8000	O	-	O	O	O	-	-	O	O
MEC 9/11/13500	O	O	O	O	O	-	-	O	O
STAR 60-72-84	O	O	O	O	O	O	O	O	O
AGRI 60-72-84	O	O	O	O	O	O	O	O	O

- Not available O Available

.../ M VERSION--.../MA VERSION (with gearbox)

ANTICLOCK
WISE



- ... / **M** the power take-off is actuated through a cardan shaft at 540 r.p.m. This version can be recognised by the gearbox placed at the front of the Rotary blades vacuum pump and by the identification plate.
- ... / **MA** the power take-off is actuated through a cardan shaft at 1000 r.p.m. This version can be recognised by the gearbox placed at the front of the Rotary blades vacuum pump, by the identification plate and by the punching placed on the upper part of the gearbox.

.../ P VERSION (for pulley application)

CLOCK
WISE



ANTICLOCK
WISE
ON REQUEST

- ... / **P** the power take-off is actuated through a pulley and belts. This version can be recognised by the cylindrical shaft with key of the power take off and by the plate, .../P pulley application.

.../ D VERSION (direct drive)

ANTICLOCK
WISE



CLOCK WISE
ON REQUEST

- ... / **D** the power take-off is actuated through a cardan shaft directly connected to the splined hub. This version can be recognised by the splined hub placed at the front of the Rotary blades vacuum pump and by the identification plate, .../D direct drive

.../H VERSION (for hydraulic drive)

CLOCK
WISE



- ... / **H** the power take-off is actuated through a gears hydraulic motor. This version can be recognised by the hydraulic motor support placed at the front and by the identification plate, .../H hydraulic drive.



.../ K VERSION –.../KA VERSION (with gearbox and hydraulic pump support)

**ANTICLOCK
WISE**



- ... / K the power take-off is actuated through a cardan shaft at 540 rpm and is designed to actuate an hydraulic pump of group 2 or group 3. This version can be recognised by the hydraulic pump support and by the identification plate.
- ... / KA the power take-off is actuated through a cardan shaft at 1000 rpm and is designed to actuate an hydraulic pump of group 2 or group 3. This version can be recognised by the hydraulic pump support, by the identification plate and by the punching placed on the upper part of the gearbox.

Versions... /K and ... /KA have been designed so that they can be used to actuate the hydraulic accessories (gate valves, draft tube, support base etc.) on the tank car because in many cases the hydraulic pump on the tractor does not have sufficient oil flow rate for all the movements. With this application all the work may be carried out from the tractor cabin by operating only one distributor

.../ G VERSION –.../GA VERSION (application for GARDA or LEDRA)

**CLOCK
WISE**



- ... / G version of Rotary blades vacuum pump that is applied on the GARDA or the LEDRA group; it cannot be used on its own. This version can be recognised by the external pinion placed at the front of the Rotary blades vacuum pump and by the identification plate.
- ... / GA version of Rotary blades vacuum pump that is applied on the GARDA or the LEDRA group at 1000 rpm; it cannot be used on its own. This version can be recognised by the external pinion placed at the front of the Rotary blades vacuum pump and by the identification plate.

All the versions of the STAR and AGRI series of Rotary blades vacuum pump can be supplied with back tank in cast iron (versions /MV, /MAV, /PV, /DV, /HV, /KV /KAV) or with extractable side tank in sheet metal (versions /MF, /MAF, /PF, /DF, /HF, /KF, /KAF).

1.1 IDENTIFICATION LABEL

Every rotary blades pump is supplied with an identification label stating:

- rotary blades pump model
- serial number
- production year
- max relative pressure
- max vacuum
- max absorbed power
- max r.p.m.
- max rate of flow
- CE mark
- weight of pump



*Every identification plate is protected by a special sky-blue colour film, to remove after painting.
This film has been introduced to guarantee the tracing of the pump for warranty purposes.*

IDENTIFICATION LABEL WITH PROTECTIVE FILM FOR PAINTING



INSTRUCTIONS FOR USE AND MAINTENANCE

2.0 - PACKAGING, STORAGE, HANDLING AND TRANSPORT

2.1 PACKAGING

The Rotary blades vacuum pump are supplied without packaging. On request the following packaging can be used:

- wooden base and shrink-wrap;
- wooden cases and shrink-wrap for shipment by sea or air.

2.2 STORAGE

In order to preserve the Rotary blades vacuum pump correctly, it must be stored:

- under cover, sheltered from adverse weather conditions;
- resting horizontally on its four feet.

The Rotary blades vacuum pump are lubricated during testing at our factory with special oil that ensures lubrication of the various internal components for approx. 6 months.

In the event of subsequent storage it is advisable to wash the inside of the body with oil and diesel oil (as stated on this manual).

2.3 HANDLING AND TRANSPORT

Mass of Rotary blades vacuum pump: (see technical sheet).



The Rotary blades vacuum pump should be:

- *Harnessed by means of metal hooks inserted in the hole for gripping, or a sling;*
- *Lifted with a hoisting truck (if on pallet), bridge crane, or crane.*
- *MEC 1000/1600 pumps must be lifted through a 1/4" gas eyebolt that has to be fitted instead of drain cock.*

The Rotary blades vacuum pump is supplied with a guard that is in compliance with EC directives. This guard should be fitted on by the fitter using the four screws supplied.

3.0 - ASSEMBLY, FITTING, INSTALLATION, DISASSEMBLY, RE-FITTING

The procedures concerning Rotary blades vacuum pump versions .../G and .../GA are given in the GARDA/LEDRA group instructions.



When carrying out maintenance operations, inspections, checks and repairs you are advised to wear the individual means of protection listed in this manual.



All maintenance operations, inspections, checks and repairs should be carried out with the greatest care and with the tractor not running and the power take-off disconnected.



It is essential to prevent sewage from entering the Rotary blades vacuum pumps. The entrance of sewage would cause the blades and consequently the rotor to break.

It is therefore necessary to equip the system with an overflow valve, "3", and a safety overflow valve, "2", between the Rotary blades vacuum pump and the tank car (see Figure 1)

3.1 INSTALLATION DRAFT



- 1 - Pump
- 2 - Secondary shut-off valve
- 3 - Primary shut-off valve
- 4 - Silencer
- 5 - Motorized joint
- 6 - Swivel joint
- 7 - Stemgate
- 8 - Overpressure valve
- 9 - Depression valve

Figure 1



3.2 DOUBLE OUTLET INSTALLATION DRAFT

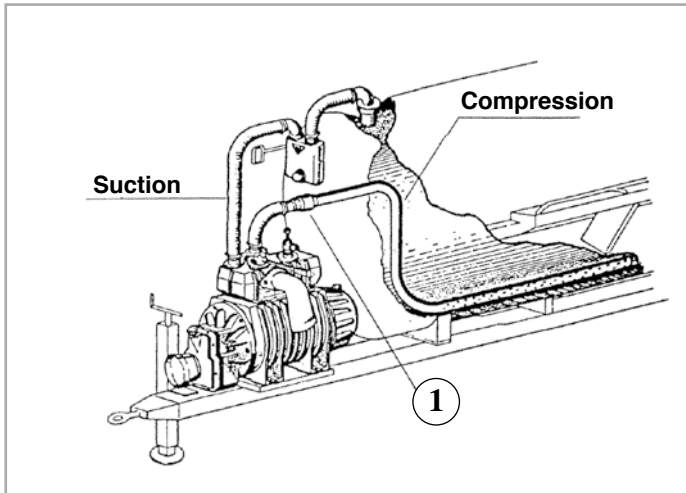

The Rotary blades vacuum pump can be used as a mixer by fitting, on request, a double outlet on the manifold (see Figure 2). In this case there will be the intake of a normal Rotary blades vacuum pump, but a perforated tube placed inside the tank car must be used for the compression. When the handle is positioned on the compression phase, the air will be forced out through the holes in the tube so causing mixing of the previously loaded sewage (never exceed the maximum working absolute pressure of 2,5 bar) equal to 1,5 relative bar.

Figure 2



With this system, a check valve (1) must be fitted on the delivery tube to prevent the transfer of sewage inside the Rotary blades vacuum pump.

3.2.1 DIAGRAM OF INSTALLATION WITHOUT MANIFOLD ON IRRIGATION MACHINES

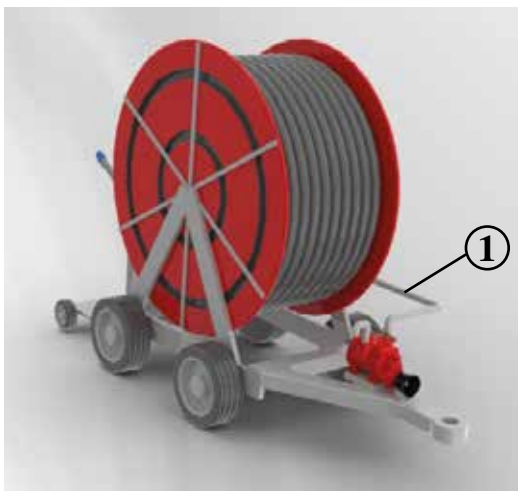

Battioni Pagani® produces a complete line of rotary blades vacuum pumps for use on irrigation machines.

To use the rotary pump correctly, the irrigation machine must be completely filled with water and must not be partially empty.

Important: never exceed the relative maximum operating pressure of 3.5 bar.



With this system, the delivery pipe must be equipped with a check valve (1) to prevent water from backing up into the rotary blades vacuum pump.

3.3 ASSEMBLY AND FITTING - INSTALLATION

The Rotary blades vacuum pump should be assembled and installed using the following procedure:

- 1) Assemble the Rotary blades vacuum pump horizontally with its feet facing downwards. The assembly position on the vehicle should be easy to access and be protected. A 5° maximum longitudinal slope of the Rotary blades vacuum pump with respect to the horizontal plane must not be exceeded.
 - 2) Bolt the Rotary blades vacuum pump using screws and nuts passing through the specially provided slots or holes in the feet;
- 3-M/K)** To install the .../M-K version Rotary blades vacuum pump, connect the cardan shaft at 540 r.p.m. of the tractor to the P.T.O. shaft of the Rotary blades vacuum pump.
- 3-MA/KA)** To install the .../MA-KA version Rotary blades vacuum pump, connect the cardan shaft at 1000 r.p.m. of the tractor to the P.T.O. shaft of the Rotary blades vacuum pump.



Don't exceed the maximum slope allowed for the cardan shaft.

3-P) To install the .../P version Rotary blades vacuum pump, attach a driven pulley to the shaft and fix it with the special screw located on the front of the shaft. The driven pulley may be fitted directly on the cylindrical shaft if the radial load is brought close to the bearing. Never transfer axial loads. Then connect the driven pulley to the driving pulley with the correct length of driving belts. The number and type of belts must be calculated according to the power to be transferred to the Rotary blades vacuum pump. When this operation has been completed, the necessary guard must be installed to isolate the driving parts (pulleys and belts) and prevent access to them by the operators.

- The best tension is the lower one where the belt doesn't slide under max loading condition
- Check frequently the tension during first 24/48 hours of running phase
- The over-tension reduces the life of belt and bearing
- Keep belts free from any material which may cause sliding
- Check periodically the transmission. Set it when sliding

To check the tension on a normal transmission, do what follows:

- measure the length of free stretch (t)
 - In the middle of free stretch of the belt (t) apply a force(perpendicular to free stretch) nought to bend the belt 1.6 mm per 100 mm in length of the free. For example, the decline of a free stretch of 1000 mm is 16 mm.
 - Compare the force you have applied and measured through a instrument with datas stated under our table. If the force is included between "minimum force" datas, it means that the belt is not enough stretched.
- If the force exceeds "max force" datas, it means that the belt is too stretched.

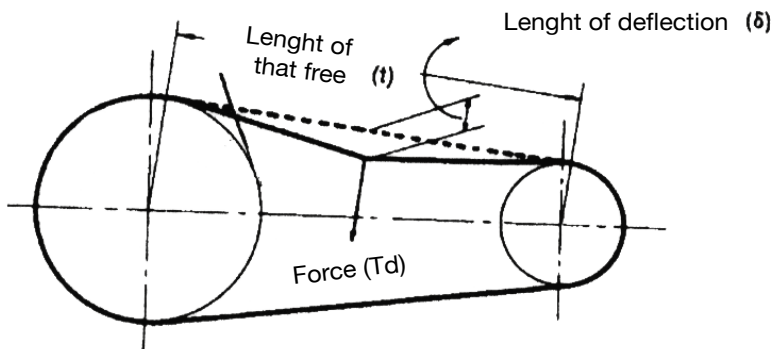

Section	Force	
	Min	Max
	Kg.	Kg.
A	0,68	1,02
B	1,58	2,38
C	2,93	4,75
D	5,77	8,61
E	9,60	14,30

3-D) To install the .../D version Rotary blades vacuum pump, connect the cardan shaft at 1000 rpm of the tractor to the P.T.O. shaft of the Rotary blades vacuum pump.



Don't exceed the maximum slope allowed for the cardan shaft.

3-H) To install the .../H version Rotary blades vacuum pump, attach an hydraulic motor (flanging European unification - Group 3,5 for MEC 2000-3000-4000-5000-6500-8000 series and Group 4 for STAR, AGRI and MEC 9000-11000-13500 series) to the power take-off shaft and fix it, using special screws, to the cast iron support located at the front.

3.4 HYDRAULIC DRAFT (/H version)

The hydraulic system required for the operation of Rotary blades vacuum pump .../H is schematized in Figure 3 and the technical characteristics of the hydraulic motor are shown in Table 2.

The splining of the hydraulic motor is of a type DIN 5482 - Z=23 for MEC 9000-11000-13500, STAR, and AGRI series and of type DIN 5482 - Z=20 for MEC 2000-3000-4000-5000-6500-8000 series.

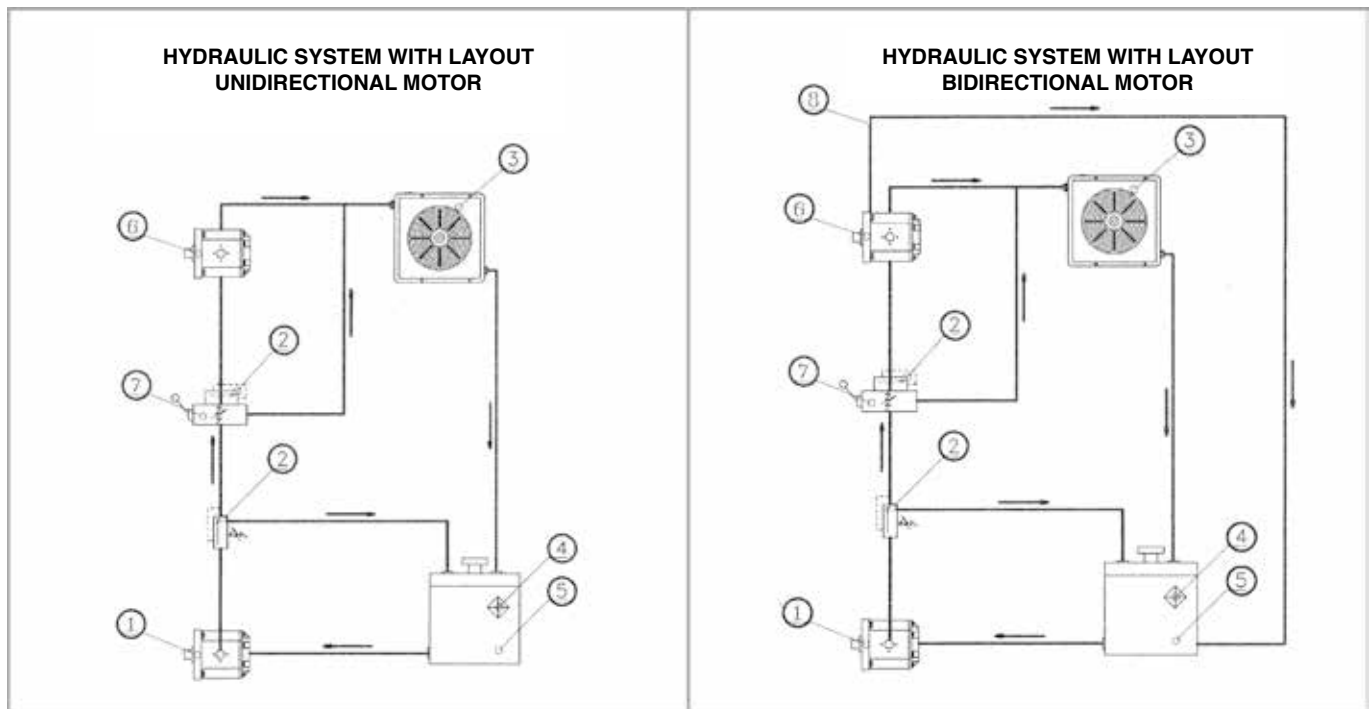

- 1 Hydraulic pump
- 2 Over-pressure valve
- 3 Radiator
- 4 Oil filter

- 5 Oil tank
- 6 Hydraulic motor
- 7 Distributor
- 8 Drainage

4) Then connect the intake/compression pipe of the tank car to the Rotary blades vacuum pump tightening it to the adjustable elbow using metal clamping bands in relation to the diameter of the pipe.

3.5 HYDRAULIC MOTOR INSTALLATION INSTRUCTION

Make sure take the rotation of the unidirectional motor is the proper are for your system. Make sure take this is a good linear matching between motor shift and power take off.

TANK. Tank capacity must be sufficient for the system's operating conditions (~ 3 times the amount of oil in circulation) to avoid overheating of the fluid. A heat exchanger should be installed if necessary. The intake and return lines in the tank must be spaced apart (by inserting a vertical divider) to prevent the return-line oil from being taken up again immediately.

LINES. The lines must have a major diameter which is at least as large as the diameter of motor or pump ports, and must be perfectly sealed. To reduce loss of load, the lines should be as short as possible, reducing the sources of hydraulic resistance (elbow, throttling, gate valves, etc.) to a minimum. A length of flexible tubing is recommended to reduce the transmission of vibrations. All return lines must end below the minimum oil level, to prevent foaming. Before connecting the lines, remove any plugs and make sure that the lines are perfectly clean.

FILTERS. We recommend filtering the entire system flow rate. Filters should be fitted as indicated in the first pages of the catalogue. Only coarse filters are recommended for pump intake.

HYDRAULIC FLUID. Use hydraulic fluid conforming to ISO/DIN standards, having viscosity as specified in the first pages of the catalogue. Avoid using mixtures of different oils which could result in decomposition and reduction of the oil's lubricating power.

ENGLISH

DRAIN HOLE: on bi-directional motors with drain hole, the hole has to be connected to the oil tank through an hose of at least 22 mm of diameter. To avoid the forming of foam inside the tank, the hose has to be connected under the minimum level.

STARTING UP. Check that all circuit connections are exact and that the entire system is completely clean. Insert the oil in the tank, using a filter. Bleed the circuit to assist in filling. Set the pressure relief valves to the lowest possible setting. Turn on the system for a few moments at minimum speed, then bleed the circuit again and check the level of oil in the tank. If the difference between pump or motor temperature and fluid temperature exceeds 10 °C, rapidly switch the system on and off to heat it up gradually. Then gradually increase the pressure and speed of rotation until the pre-set operating levels as specified in the catalogue are attained.

PERIODICAL CHECKS – MAINTENANCE Keep the outside surface clean especially in the area of the drive shaft seal. In fact, abrasive powder can accelerate wear on the seal and cause leakage. Replace filters regularly to keep the fluid clean. The oil level must be checked and replaced periodically depending on the system's operating conditions.

RESOLUTION PROBLEMS:

- Circuit is open. Downstream of the engine you have the oil reservoir and not the pump. If the engine remained in rotation with the engine off, there will be overpressure, but cavitation. To solve this problem it would take a one-way valve that lets the oil or some of it through calibration, the engine sent to his desire to avoid that the engine air pump.

- Circuit is closed. You could have an overpressure. To solve the problem or put an overpressure valve, as recommended in the key facility attached or a calibrated one-way valve that bypasses the engine. Compared to the first case, the last option is cheaper and less invasive on a system already exists as it does not require an additional hole in the tank.

HYDRAULIC MOTOR								
Hydraulic Motor	Rotary blades vacuum Pump	Max pressure of exercise	Flow rate	Rpm	Pressure	Max pressure Hydraulic system	Trasmitted Power	Torque
KM 30.51-SO	MEC 2000/H	1,5 bar	74,8 l/min	1 4 0 0	78 bar	230 bar	8 kW	57 Nm
	MEC 3000/H				107 bar		11 kW	78 Nm
	MEC 4000/H				136 bar		14 kW	99 Nm
	MEC 5000/H				165 bar		17 kW	120 Nm
	MEC 6500/H				204 bar		21 kW	148 Nm
	MEC 8000/H				218 bar		22,5 kW	158 Nm
KM 40.87-SO	MEC 9000	1,5 bar	125 l/min	1 4 0 0	174 bar	280 bar	30 kW	211 Nm
	MEC 11000				186 bar		32 kW	226 Nm
	MEC 13500				198 bar		34 kW	240 Nm
KM 40.87-SO	AGRI/STAR 60/H	1,5 bar	107 l/min	1 2 0 0	197 bar	280 bar	29 kW	239 Nm
	AGRI/STAR 72/H				210 bar		31 kW	255 Nm
	AGRI/STAR 84/H				258 bar		38 kW	312 Nm

Table 1



3.6 DISINSTALLATON

The Rotary blades vacuum pump should be disinstalled using the following procedure:

.../M-K	.../P	.../D	.../H
1) Stop the power take-off of the tractor;	1) Stop the power take-off of the tractor;	1) Stop the power take-off of the tractor;	1) Stop the hydraulic system;
2) Remove the cardan shaft from the power take-off of the rotary blades vacuum pump;	2) Remove the driving belts.	2) Remove the cardan shaft from the power take-off of the rotary blades vacuum pump.	2) Remove the hydraulic connections to the motor.
3) Remove the connecting pipe that joins the rotary blades vacuum pump to the tank car, by loosening the metal band and sliding the pipe from the adjustable elbow;	3) remove the pipe that connects the rotary blades vacuum pump to the tank car. To accomplish this, loosen the metal clamp and pull the pipe out of the elbow;	3) remove the pipe that connects the rotary blades vacuum pump to the tank car. To accomplish this, loosen the metal clamp and pull the pipe out of the elbow;	3) remove the pipe that connects the rotary blades vacuum pump to the tank car. To accomplish this, loosen the metal clamp and pull the pipe out of the elbow;
4) Remove any hydraulic connections;	4) remove any plumbing connections;	4) remove any plumbing connections;	4) remove any plumbing connections;
5) Remove the clamping screws and disinstall the rotary blades vacuum pump.	5) remove the mounting screws and remove the rotary blades vacuum pump.	5) remove the mounting screws and remove the rotary blades vacuum pump.	5) remove the mounting screws and remove the rotary blades vacuum pump.

ENGLISH

3.7 DISASSEMBLY

3.7.1 Back disassembly

SERIE MEC 1000-1600-2000-3000-4000-5000-6500-8000

- 1) Remove the back cover or the lubrication pump (together with the connector joint) from the flange;
- 2) Remove the screws from the back flange;
- 3) Use two screws for screwing into the threaded extraction holes until the flange is removed;

SERIE MEC 9000-11000-13500

- 1) Remove the rear cover or oil pump (together with the connecting joint) from the flange;
- 2) Remove the seeger ring from the rear pin;
- 3) Remove the screws from the rear flange.
- 4) Screw two screws into the threaded extraction holes just until the flange can be removed;

STAR - AGRI /V (with rear cast iron oil tank)

STAR - AGRI /F (with rear flange and extractable side sheet oil tank)

- | | |
|---|---|
| <ol style="list-style-type: none"> 1. Remove the tank cover and the lubrication pump (together with the connector joint) from the back tank; 2. Remove the screws from the back tank; 3. Use two screws for screwing into the threaded extraction holes until the tank is removed; | <ol style="list-style-type: none"> 1. Close the oil cock placet on the tank 2. Remove the back cover with the lubrication pump (together with the connector joint) from the flange; 3. Remove the screws from the back flange; 4. Use two screws for screwing into the threaded extraction holes until the flange is removed; |
|---|---|

3.7.2 Front disassembly

.../M-K	.../P	MEC 9000-11000-13500.../P	.../D	.../H
1) Unscrew the screws of the gearbox cover;	1) Remove the driven pulley and the key;	1) Remove the driven pulley and the key;	1) Remove the flange with splined shaft;	1) Disassemble the hydraulic motor from its support;
2) Use two screws for screwing into the threaded extraction holes until the cover is removed;	2) Disassemble the front cover from the flange;	2) Remove the front cover from the flange;	2) Remove the sleeve with transmission flange and key	2) Remove the hydraulic motor support;
3) Remove the gear with splined shaft using an extractor if necessary;	3) Remove the screws from the front flange;	3) Remove the seeger ring from the front pin;	3) Remove the seeger ring placed in front of the bearing;	3) Remove the clamping screw located inside the sleeve and then slide the sleeve out;
4) For the pinion: unscrew the self-locking nut, use an extractor;	4) Slide the rotor from the body;	4) Remove the screws from the front flange.	4) Remove the clamping screw from the splined hub;	4) Remove the screws from the front flange;
5) Remove the seeger ring placed in front of the bearing	5) Remove the seeger ring placed in front of the bearing;	5) Pull the rotor out from the body;	5) Disassemble the rotor from the gearbox through a press	5) Slide the rotor from the body;
6) Slide the rotor from the body together with the gearbox;	6) Disassemble the rotor from the gearbox through a press;	6) Use a press to remove the rotor from the flange.		6) Remove the seeger ring placed in front of the bearing;
7) Disassemble the rotor from the gearbox through a press;				7) Disassemble the rotor from the gearbox through a press;

3.8 RE-FITTING – RE-INSTALLATION



IMPORTANT: Before proceeding with any re-fitting, replace the gaskets of the opened parts.

3.8.1 Re-fitting of the back

SERIE MEC 1000-1600-2000-3000-4000-5000-6500-8000

- 1) Remove the bearing and the spacer from the back flange;
- 2) Replace the flange gasket;
- 3) Bring the back flange up to the pump body, aligning it with the clamping holes;
- 4) Insert the 6 clamping screws in the holes and tighten them;
- 5) Fit the bearing on the flange using a drift;
- 6) Insert the spacer;
- 7) Re-fit the back cover or the lubrication pump (together with the connector joint) on the flange.



SERIE MEC 9000-11000-13500

- 1) Remove the bearing from the rear flange;
- 2) Insert the two centering pins into the pump body;
- 3) Replace the seal on the flange;
- 4) While lining up the holes with the two pins, bring the rear flange and the pump body together;
- 5) Insert the 6 mounting screws into the slotted holes and tighten to $45 \div 55$ Nm;
- 6) Using a mallet, install the bearing on the flange;
- 7) Install the seeger ring on the rear pin;
- 8) Install the rear cover or oil pump (together with the connecting joint) back onto the flange;
- 9) Remove the centering pins.



Figure A

ENGLISH

The MEC 9000/11000/13500 pump is equipped with a system that allows the flange to slide, which prevents breakage if foreign bodies become lodged between the rotor and the pump body. (Except for version G-GA)

To benefit from this system, it is important to follow these instructions:

Before starting the pump, make sure the rotor has not dropped down accidentally. This can be accomplished by making sure the cut in the flange lines up with the cut machined into pump body (see figure A).

STAR-AGRI /V (with rear cast iron tank)	STAR-AGRI /F (with later tank)
1. Remove the bearing from the back tank;	1. Remove the bearing from the back flange;
2. Replace the pump body gasket;	2. Replace the pump body gasket;
3. Bring the back tank up to the pump body, aligning it with the clamping holes;	3. Bring the back flange up to the pump body, aligning it with the clamping holes;
4. Insert the clamping screws in the holes and tighten them;	4. Insert the clamping screws in the holes and tighten them;
5. Fit the bearing on the tank using a drift;	5. Fit the bearing on the flange using a drift;
6. Put back the tank cover and the lubrication pump (together with the connector joint) on the back tank;	6. Put back the back cover and the lubrication pump (together with the connector joint) on the back flange;
7. Fill up the oil tank with oil for lubrication;	7. Open the cock placed on the side tank

3.8.2 Re-fitting of MEC 1000-1600-2000-3000-4000-5000-6500-8000 /STAR/AGRI manifold

1. Replace the manifold gasket;
2. Position the manifold on the pump body;
3. Tighten the clamping screws of the manifold.
4. Fit the reversing gear;
5. Fit the spring onto the reversing gear;
6. Replace the gasket onto the cover with sleeve;
7. Place the cover with sleeve onto the manifold;
8. Tight the fixing screws of the cover;
9. Assemble the handle.

Reinstalling MEC 9000-11000-13500 manifold

- 1) Replace the gasket on the manifold;
- 2) Position the manifold on the pump body;
- 3) Tighten the mounting screws on the manifold;
- 4) Install the reverse gear;
- 5) Install the spring on the reverse gear;
- 6) Install the spacer onto the spring on the reverse gear;
- 7) Replace the gasket on the manifold cover;
- 8) Position the manifold cover on the manifold;
- 9) Tighten the mounting screws on the manifold cover;
- 10) Install the oil seal into its seat on the manifold cover;
- 11) Install the handle and tighten it using the screw provided;



3.8.3 Re-fitting of the front

.../M-MA-K-KA	.../P	.../D	.../H
1) Mec 5000-6500-8000-9000-11000-13500: remove the seeger;	1) Remove the seeger;	1) Remove the seeger;	1) Remove the seeger;
1) Star/Agri: disassemble no. 3 screws;	2) Remove the bearing;	2) Remove the bearing;	2) Remove the bearing;
2) Disassemble the bearing;	3) Disassemble bearing and seeger rign;	3) Disassemble bearing and seeger rign;	3) Disassemble bearing and seeger rign;
3) Replace the flange gasket;	4) Mec 9000-11000-13500: insert the pins (supplied with the unit) into the pump body;	4) Mec 9000-11000-13500: insert the pins (supplied with the unit) into the pump body;	4) Mec 9000-11000-13500: insert the pins (supplied with the unit) into the pump body;
4) Mec 9000-11000-13500: install the pins (supplied with the unit) into the pump body;	5) Replace the flange gasket;	5) Replace the flange gasket;	5) Replace the flange gasket;
5) Fix the gearbox to pump body trough screws	5) Mec 9000-11000-13500: mount the front flange on the pump body using screws tightened to 45 ÷ 55 Nm;	5) Mec 9000-11000-13500: mount the front flange on the pump body using screws tightened to 45 ÷ 55 Nm;	5) Mec 9000-11000-13500: mount the front flange on the pump body using screws tightened to 45 ÷ 55 Nm;
5) Mec 9000-11000-13500: mount the gearbox on the pump body using screws tightened to 45 ÷ 55 Nm;	6) Using a buffer, install the bearing onto the flange and install the seeger;	6) Using a buffer, install the bearing onto the flange and install the seeger;	6) Using a buffer, install the bearing onto the flange and install the seeger;
6) Using a buffer, install the bearing onto the flange and install the seeger;	6) Mec 9000-11000-13500: using a buffer, install the bearing onto the flange, install the compensation ring and install the seeger;	6) Mec 9000-11000-13500: using a buffer, install the bearing onto the flange, install the compensation ring and install the seeger;	6) Mec 9000-11000-13500: using a buffer, install the bearing onto the flange, install the compensation ring and install the seeger;
6) Mec 9000-11000-13500: using a buffer, install the bearing onto the flange, install the compensation ring and install the seeger;	7) Put the front cover back on the flange.	7) Put the front cover back on the flange.	7) Put the transmission sleeve back on the rotor pin;
7) Mec 9000-11000-13500: install the spacer and mount the pinion on the shaft;	8) Mec 9000-11000-13500: remove the centring pins from the pump body.	8) Re-fit the splined hub;	8) Re-fit the hydraulic motor support;
7) Assemble the pinion onto the shaft;		9) Mec 9000-11000-13500: remove the centring pins from the pump body.	9) Mec 9000-11000-13500: remove the centring pins from the pump body.
8) Fit the self-locking nut for fixing the pinion;			
9) Insert the gear in the bearing housing;			
10) Fit the gearbox cover;			
11) Fill up the gearbox with oil			
12) Mec 9000-11000-13500: remove the centring pins from the pump body.			



The MEC 9000/11000/13500 pump is equipped with a system that allows the flange to slide, which prevents breakage if foreign bodies become lodged between the rotor and the pump body. (Except for version G-GA)

To benefit from this system, it is important to follow these instructions:

Before starting the pump, make sure the rotor has not dropped down accidentally. This can be accomplished by making sure the cut machined into flange lines up with the cut machined into pump body.



Flange slot



Cut for aligning flange with pump body



3.8.4 CORRECT POSITIONING OF REVERSING GEAR

To position the reversing gear correctly, follow the procedure below:

1. remove the handle (MEC series) or the reversing selector;
2. remove the manifold cover;
3. check that the flat part of the reversing gear is positioned at 45° to the power take-off;
4. re-fit the manifold cover and the handle (MEC series) or the reversing selector.

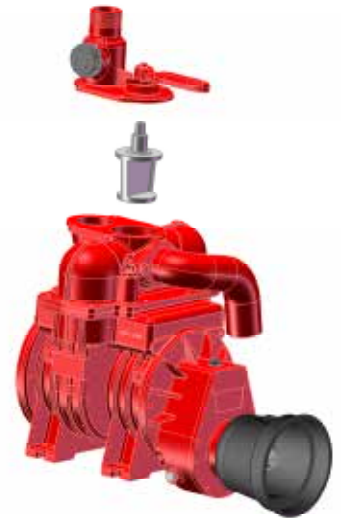

ENGLISH

4 - REVERSION OF DIRECTION OF ROTATION – ROTARY BLADES VACUUM PUMP WITH FORCE FEED OR AUTOMATIC LUBRICATION

If it is necessary to reverse the direction of rotation of a rotary blades vacuum pump with automatic lubrication, proceed as follows:

- disassemble the back cover and the automatic lubrication pump DX or SX (together with the coupling joint) from the flange;
- remove the screws from the back flange;
- use two screws in the threaded extraction holes until the flange is removed;
- remove the screws from the front flange;
- extract the rotor from the body together with the front flange;
- rotate the body together with the manifold 180° on a horizontal level;
- replace two flange gaskets;
- slide the rotor in the body together with the front flange;
- tighten the six securing screws of the front flange to the body;
- disassemble the bearing and the seeger from the back flange;
- approach the back flange to the pump body, positioning it on a level with the securing holes;
- insert the six securing screws in the holes and tighten;
- assemble the bearing on the flange by means of a stopper and fit the seeger;
- insert the spacer;
- re-assemble the back cover and replace the automatic lubrication pump DX or SX with another one with opposite direction of rotation (together with the coupling joint) to the flange.

In case of a rotary blades pump (**STAR** or **AGRI**) series with force feed lubrication, please follow the same instructions for pumps with automatic lubrication; while for rotary blades pump (**MEC**) series with force feed lubrication it is not necessary to replace the lubrication pump as it is bi-directional.

5 - START-UP

5.1 WORKING/RUNNING WITHOUT OVERPRESSURE VALVE – MEC SERIES



Before starting the rotary blades vacuum pump make sure that the hole in the manifold cover made for the overpressure valve is closed with a cap, if the overpressure and depression valves are present and working in the installation. If overpressure and depression valves are not fitted on their hole onto the rotary blades pump, close the hole by means of a cap.

5.2 DIRECTION OF ROTATION



Before starting the Rotary blades vacuum pump make sure that the P.T.O. shaft turns freely and that the direction of rotation is the same as the one indicated by the arrow.

Never turn the rotary blades vacuum pump in the direction of rotation opposite to the one for which it has been prepared (indicated by the arrow) as this could damage some components as well as prevent the operation of the pump.

6 - SET-UP OF THE LUBRIFICATION SYSTEM

Three different types of lubrication have been developed for the Rotary blades vacuum pump (see Figure 3).

6.1 NORMAL LUBRICATION

Lubrication occurs during the intake phase only. The vacuum created in the Rotary blades vacuum pump sucks oil from the tank. In the compression phase lubrication occurs with the residue of oil from the preceding phase. Normal lubrication is available only for models MEC 1000 and MEC 1600 that are manufactured with only this type of lubrication.

6.2 FORCED LUBRICATION

Lubrication occurs in both the intake phase and the compression phase through a gear pump placed at the back and actuated by the rotor shaft. The gear pump sucks oil from the tank and sends it to the manually adjusted metering tap. Excess oil returns to the tank through a tube connecting the tap to the tank. Forced lubrication is available as standard feature on models MEC, STAR, AGRI.

6.3 AUTOMATIC LUBRICATION

With this system lubrication occurs in both the intake phase and the compression phase by means of a piston metering pump with adjustable flow rate placed at the back and actuated by the rotor. The oil is injected directly into the Rotary blades vacuum pump, eliminating manual adjustment and saving a considerable amount of oil. Automatic lubrication is supplied, on request, on models MEC, STAR, AGRI.

Figure 3

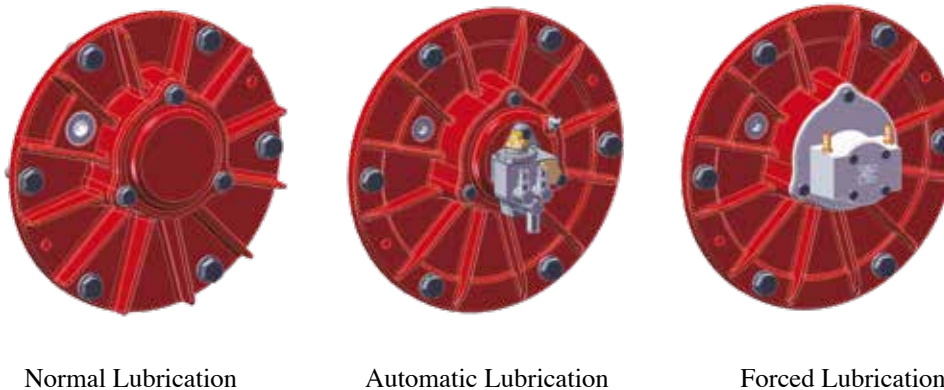

6.4 OIL TO USE

The Rotary blades vacuum pump are supplied without lubrication oil in the oil tank. BPP suggest to use “Battioni Pagani vacuum pump oil” for internal lubrication. It grants.

- Excellent resistance to oxidation
- Strong anti-rust property
- Excellent anti foam power
- Working temperature from -5 °C to 160 °C

IF “VACUUM PUMP OIL” IS NOT AVAILABLE, USE ONLY NEW MINERAL OIL MEETING ISO VG 100 (SAE 30)



6.4.1 ABSOLUTELY DO NOT USE FOLLOWING OIL TYPES:





TRANSMISSION OIL - USED OIL - HYDRAULIC OIL - VEGETABLE OIL - OIL FOR GEARS - OIL FOR BRANKES

YOU MUST USE ONLY NEW OIL

6.4.2 GEARBOX OIL

All M-MA-K-KA versions (with gearbox) are equipped with oil into the gearbox.
If you have to change the oil use only ISO VG 460.

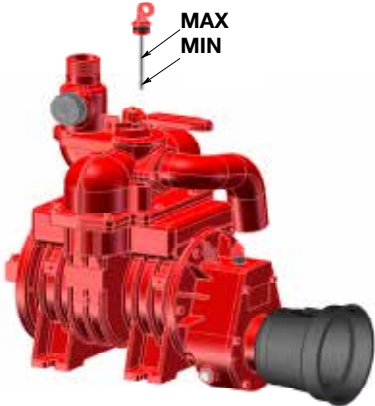
6.5 OIL LEVEL

MEC SERIES	STAR/V, AGRI/V SERIES	STAR/F, AGRI/F SERIES
 <p>Figure 4</p>	 <p>Figure 5</p>	 <p>Figure 6</p>

SERIE MEC

For internal lubrication, the minimum oil level is indicated by the notch at the lower end of the level rod (see Figure 4) located on the manifold and consequently the maximum level will be reached when the tank is full.

SERIE STAR/V, AGRI/V

For internal lubrication, the minimum oil level is indicated by the total length of the plug with level rod (see Figure 5) situated in the back tank and the maximum level will be reached with a full tank.

Serie STAR/F, AGRI/F

For internal lubrication, the minimum oil level is indicated by the lower notch on the indicator placed at the side of the external tank (see Figure 6) and the maximum level will be reached with a full tank

OIL TANK CAPACITY [L]							
MEC 1000	MEC 1600	MEC 2000	MEC 3000	MEC 4000	MEC 5000	MEC 6500	MEC 8000
0,6	0,7	1,0	1,2	1,5	2,5	3,1	3,8
MEC 9000	MEC 11000	MEC 13500	STAR/AGRI			STAR-AGRI/F	
2,5	3	3,5	3,7			4,3	

Table 2

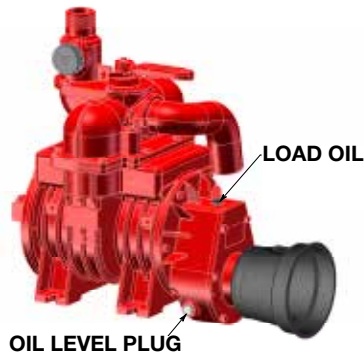

M – MA – K – KA VERSIONS: the gearbox has an oil loading plug at the top of the gearbox and an oil level plug (see Figure 7), placed on the side of the gearbox to allow the level to be checked

To ensure correct lubrication, the oil should always be visible in the oil level.

Figure 7

6.6 QUANTITY OF LUBRICATION OIL

When the Rotary blades vacuum pump is running, check that the quantity of oil indicated in Table 4 is dripping from the special regulator tap. These quantities are valid for both Forced and Automatic Lubrication. When necessary, add only unused clean oil to the tank.

/M – MA – K – KA VERSIONS: make the first oil change in the gearbox after approx. 100 working hours and subsequent changes approx. every 300 working hours.

MODEL	Drop/min at max vacuum	Drop/min air flow free air	g/h at max vacuum	g/h air flow free air
MEC 1000	20 - 25	10 - 12	50	25
MEC 1600	20 - 25	10 - 12	50	25
MEC 2000	25 - 30	12 - 15	63	32
MEC 3000	25 - 30	12 - 15	63	32
MEC 4000	25 - 30	12 - 15	63	32
MEC 5000	30 - 40	15 - 20	80	40
MEC 6500	40 - 50	20 - 25	100	50
MEC 8000	40 - 50	20 - 25	100	50
MEC 9000	50 - 60	25 - 30	120	60
MEC 11000	50 - 60	25 - 30	120	60
MEC 13500	50 - 60	25 - 30	120	60

MODEL	Drop/min for each drain cock at max vacuum	Drop/min for each drain air flow free air	g/h for each drain cock at max vacuum	g/h for each drain air flow free air
STAR 60	30 - 40	15 - 20	80	40
STAR 72	35 - 45	17 - 22	90	45
STAR 84	40 - 50	20 - 25	100	50
AGRI 60	30 - 40	15 - 20	80	40
AGRI 72	35 - 45	17 - 22	90	45
AGRI 84	40 - 50	20 - 25	100	50

Table 3



6.7 REGULATION FOR LUBRICATING OIL

To adjust the dripping of oil in the Rotary blades vacuum pump with forced lubrication, turn the regulator ring nut “A” (see Figure 8) after loosening ring nut “B”.

Tighten ring nut “B” again when adjustment has been completed.

The adjustment of oil delivery, in automatic lubrication, is carried out at our factory during final testing of the Rotary blades vacuum pump.

If, for any reason, a different setting is required proceed as follows: remove pin cover “B” (see Figure 9), loosen lock nut “C” and then turn regulator pin “A”.

By rotating clockwise lower oil delivery is obtained (-), and by rotating anticlockwise higher oil delivery is obtained (+). When adjustment has been completed tighten lock nut “C” and screw cover.

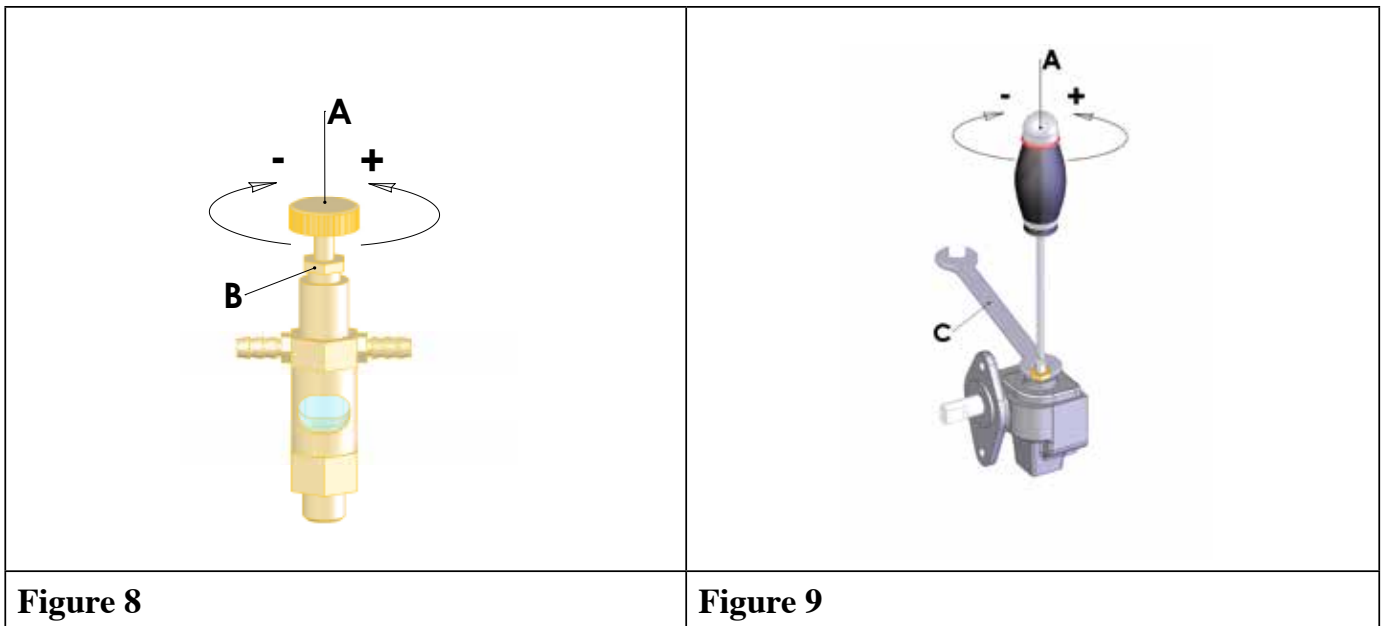

Figure 8

Figure 9

7 – OVERPRESSURE AND VACUUM ADJUSTMENT VALVES

The following diagram describes the valves as series (O), on demand (X) and not available (-) for each model of rotary blades vacuum pump.

	VACUUM ADJUSTMENT VALVE 1" 1/2	OVERPRESSURE VALVE 1" 1/4	OVERPRESSURE VALVE 1" 1/2	OVERPRESSURE VALVE 2"
MEC 1000/1600	-	-	-	-
MEC 2/3/4000	-	X	-	-
MEC 5/6.5/8000	X	-	X	-
MEC 9/11/13500	X	-	-	X
STAR 60/72/84	O	-	-	X
AGRI 60/72/84	O	-	-	X

O = As Series

X = on request

- = Not available

Table 4

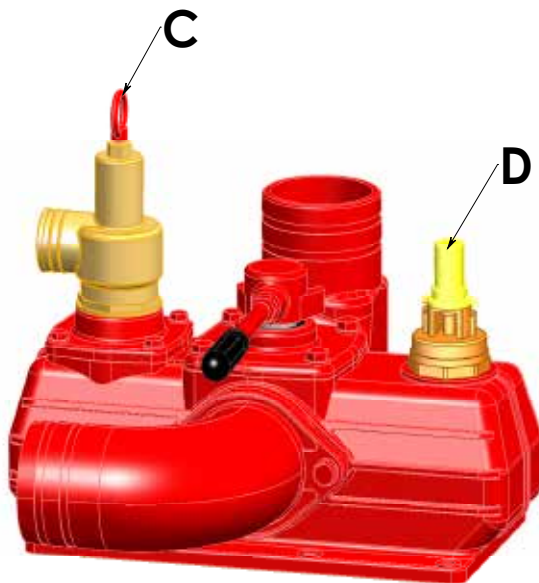

ATTENTION: the installation must be always equipped with depression valve (set at $-0,80$ bar) and with overpressure valve (set at 1 bar).

Pressure: the maximum allowed pressure is 2,5 absolute bar (1,5 relative bar). In order to avoid exceeding this value or to obtain a lower max pressure, an overpressure valve, “C”, must be applied that is of a size capable of discharging the excess air delivery.

Vacuum: too high a vacuum may cause ovality and waviness of the body or breaking of the blades.

It is therefore advisable to use a vacuum regulator valve, “D”. These valves may be fitted on the manifold cover or on manifold of the Rotary blades vacuum pump. Vacuum working degree is of $-0,80$ bar.

The regulation of the valves is done by acting on the throttle placed on the valve same (overpressure valve) or action on nut and locknut (vacuum adjustment valve).

Figure 10

8 - TESTING AND RUNNING IN

8.1 TESTING

All the Rotary blades vacuum pump Battioni Pagani are tested before the delivery at our plant.



In order to test the Rotary blades vacuum pump check the preceding points, using a workbench if necessary.

Make sure that the P.T.O. shaft turns freely and that the direction of rotation is the same as the one indicated by the arrow.



If operation of the pump is checked without it being connected to the suction/delivery tubes there will be danger to operators' hands due to access to the inside of the discharge elbow. In this situation there is also the danger that foreign bodies will be sucked into the machine.

Check that the position of the handle is correct and test that the Rotary blades vacuum pump exhausts or compresses.

8.2 RUNNING IN

The running in period foreseen for a rotary blades pump is of 30 of effective working. During that period the working parameters must be reduced of 20%



9 - START, OPERATION, STOP

9.1 START

The Rotary blades vacuum pump does not have a start button. Therefore to start it just transmit the motion to the power take-off (P.T.O.). The way this is done depends on the version of Rotary blades vacuum pump. Before starting make sure that the rotary blades vacuum pump is supplied with oil for internal lubrication (and lubrication of gearbox in versions .../M-MA and .../K-KA).



Before starting the rotary blades vacuum pump, make sure that the guards on all the moving parts are in place and efficient. Any damaged or missing components must be replaced and installed correctly before using the transmission.

For .../M-MA, K-KA, D version clean and grease the power take off before to install the cardan transmission.

9.2 OPERATION



Do not use the Rotary blades vacuum pump at pressures, temperatures, times higher than those indicated in Table 6. During use do not exceed the speed and power limits set in this manual. Do not overload the machine or suddenly engage the P.T.O.

Check the following operating parameters.

PARAMETER		WORKING RATE	MAXIMUM RATE
Revs M, K	[rpm]	450-500	600
Revs P, D, H,	[rpm]	1000	1200
Revs MA, KA	[rpm]	800	1000
Pressure	[bar]	0,5 – 1	1,5
Vacuum	[%]	80 %	95 %
Outside temperature side cylinder compression [°C]		80 – 90	130
Time	[min]	3-5	6-8
Working time with long life blades [min]		6-8	15
Working time ballast version –0,65 bar		continuous	continuous

Table 5



Failure to comply with the instructions given in this manual may be dangerous for the user health or may damage the rotary blades vacuum pump. If density of material to suck is high, dilute or mix the material same. The working time should be such that the maximum temperature is never reached. Prolonged operation without interruption may cause damage to the blades as well as overheating.

9.3 STOP

To stop the rotary blades vacuum pump, stop the engine and disconnect the P.T.O. in order to prevent accidental operation of it.

9.4 CONTROLS

A handle, located at the top of the manifold, is provided for the control of intake and compression phases. This can be operated manually. To state in which direction the handle has to be turned to select suction or compression phase, follow the instructions given by the manufacturer of the installation. If the reverse gear locks up, use a lever to lift the handle.



Selection of the intake or compression phase with the handle must be made with the Rotary blades vacuum pump not operating.

9.5 TEMPERATURE INDICATOR (THERMO TAPE)

Thermo Tape is affixed on the compression side of all Mec 9000-11000-13500 versions.

This temperature indicator provides two temperature readouts:

- The reversible scale at the bottom changes colour (from black to blue) at a specific temperature (90 ° C to 120 ° C). The scale is provided to help the user prevent the pump from overheating.
- A blue square with a white dot at the centre (a non-reversible indicator) is located at the upper right on the scale. If the dot turns black, the temperature has exceeded 160 ° C, which means the pump has been used for more than 15 minutes at its maximum vacuum level (which is an incorrect use). If this occurs, the pump must be disassembled and all the seals, oil seals and blades must be replaced.



9.6 PROTECTIVE DEVICES



The Rotary blades vacuum pump, when being installed on a machine, must be equipped with a protective device to isolate the moving parts and prevent access to them by the operators.



It is necessary to protect the Rotary blades vacuum pump to avoid the remote danger of material projection in case of heavy breakage.

.../M-MA, K, KA and D versions are equipped with a CE plastic protective device. It insulates and protects the P.T.O. shaft during moving.

9.7 INDIVIDUAL MEANS OF PROTECTION TO BE USED



When operating the Rotary blades vacuum pump, it is necessary to use the individual means of protection prescribed by the Manufacturer of the machine on which the Rotary blades vacuum pump has been installed.



10 - TROUBLESHOOTING

PROBLEM	CAUSE	REMEDY
Little vacuum or pressure	Blades are worn	Replace blades
	Some blades jammed in rotor	Disassemble rotary blades vacuum pump, clean and wash rotor, blades, and body
	Air infiltration or leakage from system	Eliminate infiltrations
	Undulated cylinder	Smooth or replace the body
	Reversing gear badly positioned	Remove reversing gear and position it correctly
	Flange assembly too tight	Add a gasket to the back flange
Overheating	Excessive pressure	Reduce pressure
	Excessive rate of revs	Reduce rate of revs
	Excessive operating time	Reduce operating time
	Blades too long	Trim blades to correct size
	Lack of lubrication	Check oil level in tank, oil pump operation, setting of oil tap
Beating against external surface	Rate of revs too low	Increase rate of revs
	Excessive/short and/or not suitable lubrication oil	Clean the rotary blades pump and replace the oil
Sewage comes out of discharge elbow	Malfunctioning of valves	Check valves
Smoke comes out of discharge elbow	Excessive lubrication	Adjust lubrication
No circulation of lubricating oil (for versions with automatic lubrication)	Air intake at pipe fittings	Replace pipe fittings
	Lubrication tube badly inserted in pipe fittings	Insert lubrication tube correctly
	Air in oil pump chamber	Fill pump chamber with oil
P.T.O. does not rotate	Broken blades	Replace blades (check if rotor pin is bent)
	Foreign body in rotary blades vacuum pump	Remove foreign body
No suction / no compression	Handle incorrectly positioned	Position handle correctly
	Reversing gear incorrectly positioned	Position reversing gear correctly
	Rotary blades vacuum pump rotates in wrong direction	Reverse direction of rotation
	All blades jammed	Disassemble rotary blades vacuum pump, clean and wash blades, rotor and body
	Blades protrude from the rotor slots anomalously	Disassemble rotary blades vacuum pump, clean and wash blades, rotor and body
	Rubber ball closes overflow valve	Increase passage of air inside valve

11 - MAINTENANCE, INSPECTIONS AND CHECKS, REPAIRS, TECHNICAL ASSISTANCE



When carrying out maintenance operations, inspections, checks or repairs it is advisable to wear the individual protective devices listed in this manual.



All maintenance operations, inspections, checks and repairs must be carried out with the greatest care and with the Rotary blades vacuum pump off and the P.T.O. disconnected.

11.1 CLEANING

11.1.1 WASHING OF THE BODY

If sewage enters the Rotary blades vacuum pump, the inside of the body must be washed immediately, by making it suck in diesel or fuel oil through the discharge elbow with the Rotary blades vacuum pump in compression phase. After this operation make it suck in oil. The same operation should be carried out when the Rotary blades vacuum pump has to remain inactive for a long time. In this case, disconnect the suction and delivery tube connected to the valves and hermetically seal the manifold cover because the gasses that form inside the tank would pass into the Rotary blades vacuum pump and cause the inside of the body to rust and this in turn could cause the blades to break when the system is re-started.

In order to avoid rust formation, do not use water.

If the body is washed after it is disassembled, it is advisable to carry out a preliminary wash with detergents (e.g. thinners) before carrying out the above operation.

11.1.2 WASHING OF OIL TANK

Wash the oil tank at least once a year. Remove the manifold, and then wash it using solvents.

11.1.3 WASHING AND CLEANING OF VALVES

Wash and clean the valves at least once a month. Remove the valves, then wash them with water or, if necessary, non-corrosive detergents.

11.2 CHECKING OF VALVES

Regularly check that all the valves, for both overflow and pressure/vacuum, are still working efficiently.

11.3 INSPECTION AND REPLACEMENT OF Blades

11.3.1 GENERAL INFORMATION ON BLADES

Three material type of blades are fitted on Rotary blades vacuum pump. The following Tabella 8 describes what kind of material is fitted for each series.

SERIES	STANDARD Blades	SPECIAL Blades
MEC 1000/8000	O	X
MEC 9/11/13500	-	O
STAR	O	X
AGRI	-	O

O = As series

X = On request

- = Not available

Table 8



Standard blades are suitable for no-strong uses, for short and not frequent periods.

Special blades are made of a special material suitable for strong uses and for Rotary blades vacuum pump used in agricultural field. These blades offer an excellent resistance to wear and mechanical and thermal stress. These are suitable for more frequent uses and to suck thick sewages. They are recommended for installation with frequent uses even during the same day.

Apart from normal wear, it may be necessary to replace the blades following incorrect use of the Rotary blades vacuum pump. The most frequent causes come from heat, lack of lubrication, entrance of sewage, high pressure or vacuum, formation of rust inside the body due to prolonged inactivity.

With the heat too high pallets stretch to touch the plate front and rear, this causes the breakdown of the pallets.

Lack of lubrication means the blades are completely dry like the inside of the pump. This increases their fragility and causes them to break lengthways.

The same type of breakage can be caused by entrance of sewage or by a too high working pressure.

A too high vacuum causes the blades to beat against the cylinder with consequent damage to the outside of the blades. Moreover, the lining becomes wavy.

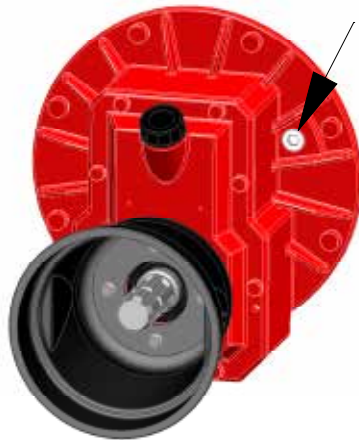

Figure 11

11.3.2 INSPECTION OF BLADES MEC/STAR/AGRI

To check the state of wear of the blades in the Rotary blades vacuum pump proceed as follows:

- Remove the threaded inspection plug;
- Rotate the rotor until a blades lines up with the inspection hole;
- Compare the height of the blades with the reference ring on the rotor;
- Replace the entire set of blades when the height is less than the reference ring on the rotor.



11.3.3 REPLACEMENT OF BLADES

- 1) Check that there is sufficient space at the back of the Rotary blades vacuum pump to be able to work easily; if there is not, the Rotary blades vacuum pump should be taken off its support beforehand;
- 2) Remove the back
- 3) Extract the blades from the rotor;
- 4) Replace the blades;
- 5) Clean the Rotary blades vacuum pump.
- 6) Re-fit the back of the Rotary blades vacuum pump
- 7) Use original spare parts Battioni Pagani® only



Ask for Rebuild kit for rotary blades vacuum pump which is made of: original Battioni Pagani® blades, gaskets, oilseals in one blister only.

11.3.4 BLADES SIZES

MODEL	Blades NUMBER	Blades SIZE
MEC 1000	5	120x38x6,5
MEC 1600	5	190x38x6,5
MEC 2000	7	180x41x6,5
MEC 3000	7	240x41x6,5
MEC 4000	7	300x41x6,5
MEC 5000	7	300x46,5x6,5
MEC 6500	7	370x46,5x6,5
MEC 8000	7	450x46,5x6,5
MEC 5000 S.C.	5	299x46,5x9,7
MEC 6500 S.C.	5	369x46,5x9,7
MEC 8000 S.C.	5	449x46,5x9,7

MODEL	Blades NUMBER	Blades SIZE
MEC 9000	5	300x60x6,5
MEC 11000	5	370x60x6,5
MEC 13500	5	460x60x6,5
MEC 9000 S.C.	5	299x60x9,7
MEC 11000 S.C.	5	369x60x9,7
MEC 13500 S.C.	5	459x60x9,7
MEC 9000 ballast	8	300x60x6,5
MEC 11000 ballast	8	370x60x6,5
MEC 13500 ballast	8	460x60x6,5
STAR 60	6	350x70x7,5
STAR 72	6	400x70x7,5
STAR 84	6	480x70x7,5
AGRI 60	6	350x70x4,7
AGRI 72	6	400x70x4,7
AGRI 84	6	480x70x4,7

Table 9



IMPORTANT: check that blades received as spare parts have a length lower or equal to nominal measure stated under our Table 9

11.4 REPLACEMENT OF RUBBER BALL

1. Unscrew and raise the valve-holder cover (AGRI and STAR series) or the manifold (MEC series);
2. Replace the rubber ball;
3. Re-fit the valve-holder cover (AGRI and STAR series) or the manifold (MEC series).

11.5 REPLACEMENT OF GEARS (version /M - MA and /K - KA)

1. Unscrew the screws of the gearbox cover;
2. Use two screws for screwing into the threaded extraction holes until the cover is removed;
3. Take out the gear with splined shaft using an extractor if necessary;
4. For the pinion: unscrew the self-locking nut, use an extractor.



11.6 TECHNICAL ASSISTANCE

Contact the supplier of the complete system for technical assistance or supply of accessories and spare parts.

11.7 REGULAR SERVICING

SERVICING TO BE CARRIED OUT	HOW TO PROCEED	FREQUENCY
Check oil circulation	Inspect the level sight glasses	Once a day
Check oil level in tank	Use the oil level on outside of tank	Once a week
Check wear of blades	Remove threaded plug	Every 300 working hours
Check that the over-pressure and vacuum regulator valves are working correctly	Remove valves	Once a week
Wash oil tank	Remove tank	Once a year
Wash body internally	Put in oil + diesel oil (after washing lubricate with oil only)	Whenever sewage enters or when inactive for a long time
Wash lubrication pump	Use a brush and compressed air	Once a year or for prolonged inactivity
Check that the overflow valves are working correctly	Remove valves	Once a month
Lubricate the power take-off (versions M - MA - K - KA and D)	Oil the P.T.O. with a brush and lubricating oil	Once a month
Wash and clean the valves	Remove valves	Once a month

12 - PUTTING OUT OF SERVICE AND DEMOLITION

Before demolishing the Rotary blades vacuum pump the following materials should be separated:

- lubricating oil;
- parts in rubber and plastic;
- parts in cast iron and steel;

and disposed of correctly.

Do not discard the Rotary blades vacuum pump in the environment.

For disposal of the lubricating oil make use of specialised treatment services.