



Catalogo generale ricambi

General spare parts catalogue

Catalogue générale des pièces de rechange

Ersatzteile-katalog

Catálogo de piezas



Battioni®
Pagani

Setting the pace since 1953



**Battioni®
Pagani**

BALLAST 3500-4500-6000-7500 / H

Rel. 0 del 15.01.2018

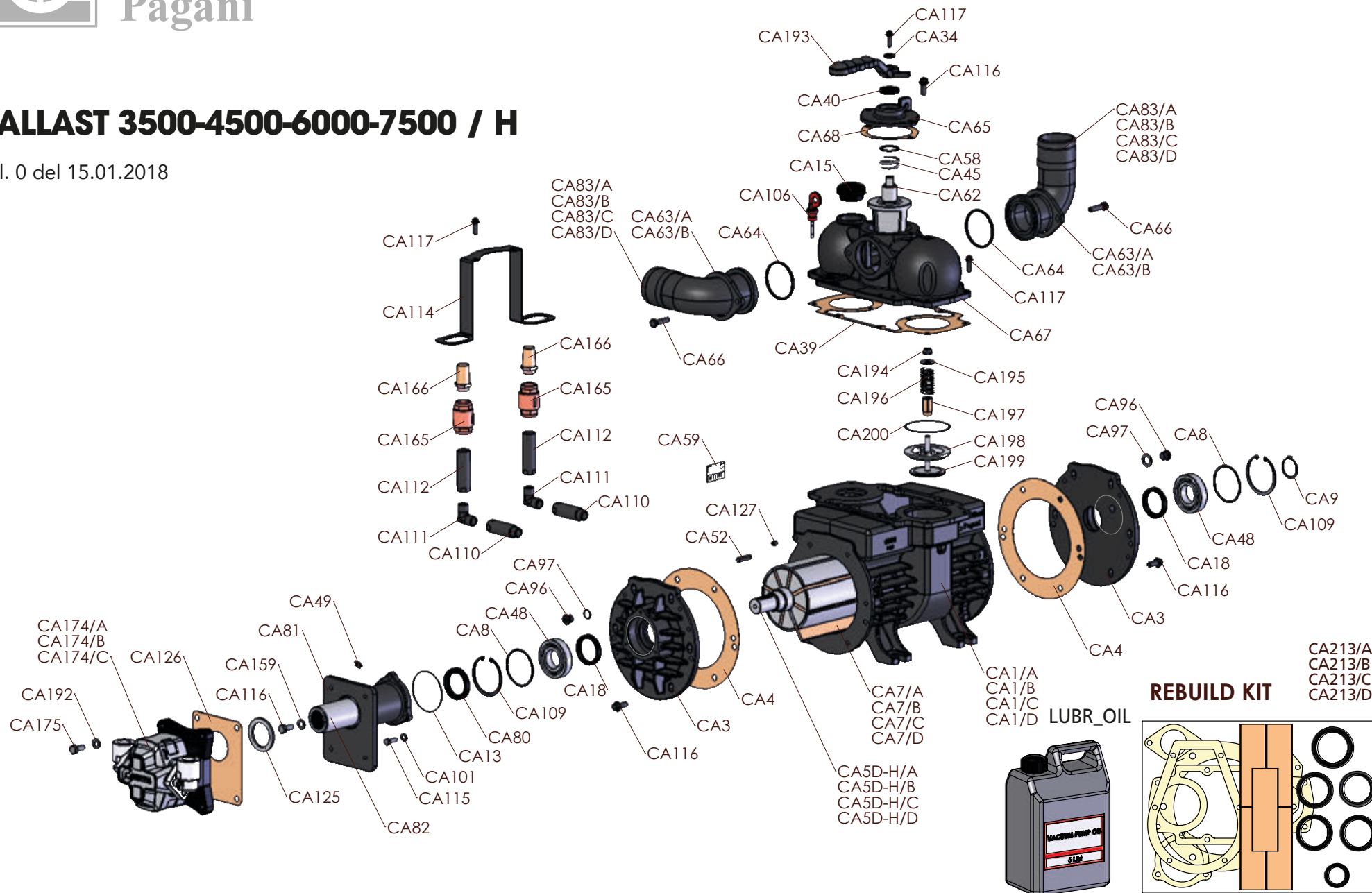

REBUILD KIT

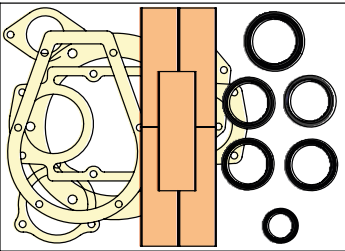

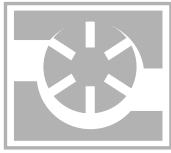

BALLAST 3500-4500-6000-7500 AUTOMATIC LUBRICATION

Rel. 0 del 15.01.2018

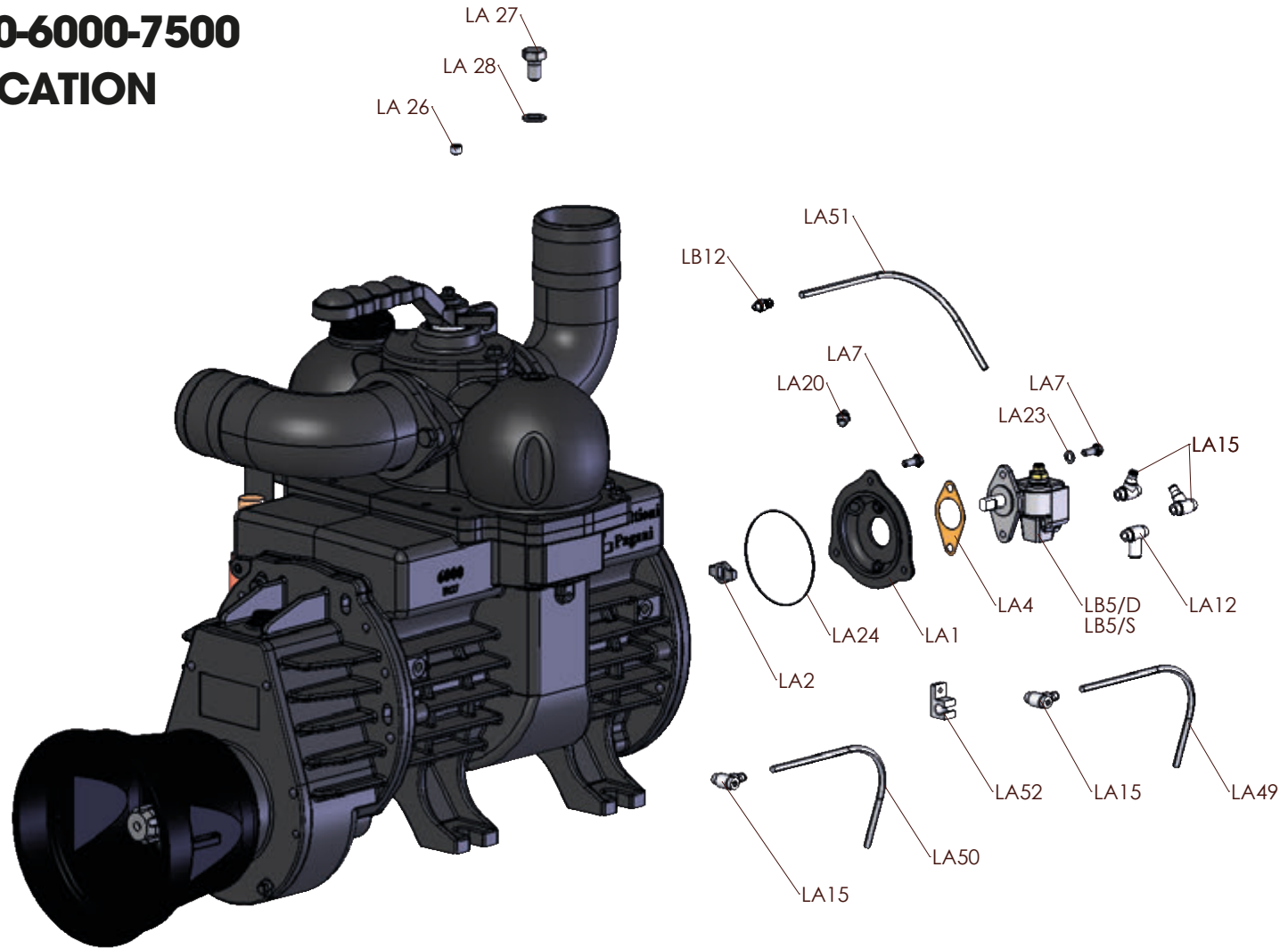



Battioni®
Pagani

BALLAST 3500-4500-6000-7500 FORCED LUBRICATION

Rel. 0 del 15.01.2018

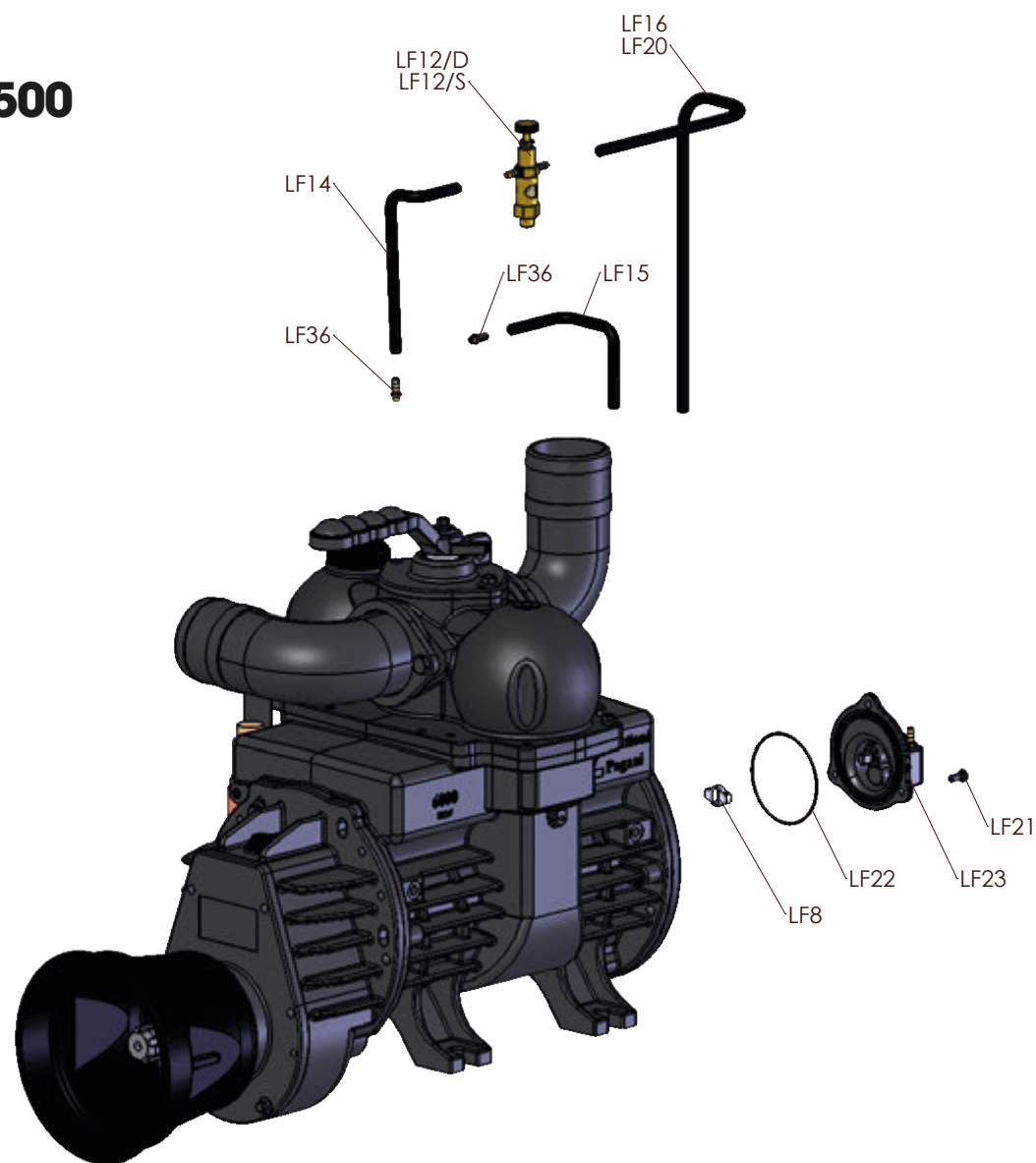



BALLAST 3500-4500-6000-7500

<i>Articolo</i> (Article)	<i>Codice</i> (Code)	<i>Descrizione</i>	<i>(Description)</i>	<i>Q.ty</i>	<i>Um</i>
CA1/A	4010101134	CORPO POMPA BALLAST 3500 LA	HOUSING - BALLAST 3500 LA	1	n
CA1/B	4010101138	CORPO POMPA BALLAST 4500 LA	HOUSING - BALLAST 4500 LA	1	n
CA1/C	4010101145	CORPO POMPA BALLAST 6000 LA	HOUSING - BALLAST 6000 LA	1	n
CA1/D	4010101149	CORPO POMPA BALLAST 7500 LA	HOUSING - BALLAST 7500 LA	1	n
CA2	4010301031	SCATOLA MOLT. BALLAST 3500-4500-6000-7500/M	GEARBOX - BALLAST 3500-4500-6000-7500/M	1	n
CA3	4010401073	FLANGIA ANT.POST.BALLAST 3500-4500-6000-7500	FRONT & BACK FLANGE BALLAST 3.5-4.5-6-7500	2	n
CA4	4030108066	GUARN. FLANGIA BALLAST 3,5-7500	FLANGE GASKET - BALLAST 3,5-7500	2	n
CA5D-H/A	4010220211	ROTORE BALLAST 3500/D-H	ROTOR - BALLAST 3500/D-H	1	n
CA5D-H/B	4010220212	ROTORE BALLAST 4500/D-H	ROTOR - BALLAST 4500/D-H	1	n
CA5D-H/C	4010220205	ROTORE BALLAST 6000/D-H	ROTOR - BALLAST 6000/D-H	1	n
CA5D-H/D	4010220206	ROTORE BALLAST 7500/D-H	ROTOR - BALLAST 7500/D-H	1	n
CA5M/A	4010220209	ROTORE BALLAST 3500/M	ROTOR - BALLAST 3500/M	1	n
CA5M/B	4010220210	ROTORE BALLAST 4500/M	ROTOR - BALLAST 4500/M	1	n
CA5M/C	4010220203	ROTORE BALLAST 6000/M	ROTOR - BALLAST 6000/M	1	n
CA5M/D	4010220204	ROTORE BALLAST 7500/M	ROTOR - BALLAST 7500/M	1	n
CA5P/A	4010220207	ROTORE BALLAST 3500/P	ROTOR - BALLAST 3500/P	1	n
CA5P/B	4010220208	ROTORE BALLAST 4500/P	ROTOR - BALLAST 4500/P	1	n
CA5P/C	4010220201	ROTORE BALLAST 6000/P	ROTOR - BALLAST 6000/P	1	n
CA5P/D	4010220202	ROTORE BALLAST 7500/P	ROTOR - BALLAST 7500/P	1	n
CA6	5050707004	CHIAVETTA 8X7X25	KEY - 8X7X25	1	n
CA7/A	4070113232	PALETTA LONG LIFE BALLAST 3500 205X43X6.5	LONG LIFE BLADE - BALLAST 3500 205X43X6.5	8	n

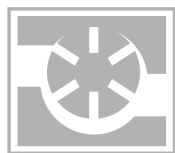

BALLAST 3500-4500-6000-7500

<i>Articolo</i> (Article)	<i>Codice</i> (Code)	<i>Descrizione</i>	<i>(Description)</i>	<i>Q.ty</i>	<i>Um</i>
CA7/B	4070113233	PALETTA LONG LIFE BALLAST 4500 260X43X6.5	LONG LIFE BLADE - BALLAST 4500 260X43X6,5	8	n
CA7/C	4070113234	PALETTA LONG LIFE BALLAST 6000 350X43X6.5	LONG LIFE BLADE - BALLAST 6000 350X43X6,5	8	n
CA7/D	4070113235	PALETTA LONG LIFE BALLAST 7500 430X43X6.5	LONG LIFE BLADE - BALLAST 7500 430X43X6,5	8	n
CA8	5012207001	ANELLO DI COMPENSAZIONE Ø 80-LMKAS 80 B	COMPRESSION & THRUST RING D80	2	n
CA9	5050507017	ANELLO SEEGER D 40 E - DIN 471 -	CIRCLIP - D 40 E	1	n
CA12	5012107010	CUSCINETTO A SFERE 6307	BALL BEARING - 6307	1	n
CA13	5030210028	ANELLO TENUTA OR 2337-85.34X1.78POMPA LF	SEAL RING - OR 2337 LF PUMP	1	n
CA15	5060605005	TAPPO NERO D 1"1/2 GAS	BLACK CAP - D 1"1/2	1	n
CA18	5030300042	PARAOLIO 48X62X10 DCV - FKM	OIL SEAL - 48X62X10 DCV - FKM	2	n
CA21	5060605001	TAPPO CARICO OLIO D 3/8" GAS	OIL PLUG - D 3/8" GAS	1	n
CA23	5050107018	VITE M 10X16 TE	SCREW - M 10X16 TE	1	n
CA24	5050202002	RONDELLA D 10X16X1,5 ALLUMINIO	ALUMINIUM WASHER - D 10X16X1,5	4	n
CA25	5012107006	CUSCINETTO A SFERE 6304	BALL BEARING - 6304	1	n
CA26	4020507002	INGR. CON ALBERO MEC 2-5000 Z55-M2,5	GEAR WITH SHAFT - Z55-M2,5 MEC 2-5000	1	n
CA27	5030300005	PARAOLIO 35X62X10	OIL SEAL - 35X62X10	1	n
CA28	4030108006	GUARN. COPERCHIO SCAT. MOLT. MEC 2-8000	GEARBOX COVER GASKET - MEC 2-8000	1	n
CA30	5060105004	TAPPO LIVELLO OLIO D 3/8" GAS	OIL LEVEL PLUG - D 3/8" GAS	1	n
CA32	5050300001	DADO AUTOBLOCCANTE M 24X2X15	SELF-LOCKING NUT - M 24X2X15	1	n
CA33	4020607062	PIGNONE BALLAST 3500-7500 Z21-M2,5 CH.8	PINION - Z21-M2,5 BALLAST 3500-7500/M	1	n
CA34	5050207032	RONDELLA D 10X28X4 - DIN 6340	WASHER - D 10X28X4 - DIN 6340	1	n
CA39	4030109046	GUARN. COLLETTORE BALLAST 3,5-7500	MANIFOLD GASKET - BALLAST 3,5-7500	1	n



BALLAST 3500-4500-6000-7500

<i>Articolo</i> (Article)	<i>Codice</i> (Code)	<i>Descrizione</i>	<i>(Description)</i>	<i>Q.ty</i>	<i>Um</i>
CA40	5030300007	PARAOLIO 30X40X7 TC	OIL SEAL - 30X40X7	1	n
CA45	4012007014	MOLLA BALLAST 3500-4500-6000-7500	SPRING BALLAST 3500-4500-6000-7500	1	n
CA48	5012107004	CUSCINETTO A SFERE 6208	BALL BEARING - 6208	2	n
CA49	5050812001	INGRASSATORE M 10X1	LUBRICATOR - M 10X1	1	n
CA52	5050707007	CHIAVETTA 8X7X50	KEY - 8X7X50	1	n
CA53	5030300002	PARAOLIO 35X52X10	OIL SEAL - 35X52X10	1	n
CA56	5050107005	VITE M 6X16 TE	SCREW - M 6X16 TE	5	n
CA57	4011707110	DISTANZIALE ROTORE BALLAST 3,5-4,5-6-7500M-G	SPACER ROTOR BALLAST 3,5-7500/M-G	1	n
CA58	5050207037	RONDELLA PER CONO INVERT. BALLAST 3500-7500	TEFLON WASHER REV.GEAR BALLAST 3,5-4,5-6-7500	1	n
CA59	5101800000	THERMO LABEL	THERMO LABEL	1	n
CA62	4010701019	CONO INVERTITORE BALLAST 3500-4500-6000-7500	REVERSING GEAR BALLAST 3500-4500-6000-7500	1	n
CA63/A	4010406030	FLANGIA PREMICURVA - Ø45 e Ø60	SUPPORT FLANGE - Ø45 e Ø60	2	n
CA63/B	4010406004	FLANGIA PREMICURVA - Ø76 e Ø80	SUPPORT FLANGE - Ø76 e Ø80	2	n
CA64	5030210019	ANELLO TENUTA OR 179	SEAL RING - OR 179	2	n
CA65	4010601078	COPERCHIO COLLETTORE MEC 5-6,5-8000 UL	MANIFOLD COVER - MEC 5-6,5-8000 UL	1	n
CA66	5050107022	VITE M10X40 TE	SCREW-M10X40 TE	4	n
CA67	4010501030	COLLETTORE BALLAST 3500-4500-6000-7500	MANIFOLD BALLAST 3500-4500-6000-7500	1	n
CA68	4030109027	GUARN. COPERCHIO COLL. MEC 5-8000 UL	MANIFOLD COVER GASKET - MEC 5-8000 UL	1	n
CA80	5030300013	PARAOLIO 55X68X8	OIL SEAL - 55X68X8	1	n
CA81	4011001016	SUPPORTO MOTORE IDRAULICO	HYDRAULIC MOTOR SUPPORT	1	n
CA82	4020107007	MANICOTTO DI TRASMISSIONE MOT. IDR.	HYDR. MOTOR TRANSM. COUPLING	1	n



BALLAST 3500-4500-6000-7500

<i>Articolo</i> (Article)	<i>Codice</i> (Code)	<i>Descrizione</i>	<i>(Description)</i>	<i>Q.ty</i>	<i>Um</i>
CA83/A	4010901023	CURVA DI SCARICO ORIENT. D 45	REVOLVING ELBOW - D 45	2	n
CA83/B	4010901024	CURVA DI SCARICO ORIENT. D 60	REVOLVING ELBOW - D 60	2	n
CA83/C	4010901013	CURVA DI SCARICO ORIENT. D 76	REVOLVING ELBOW - D 76	2	n
CA83/D	4010906004	CURVA DI SCARICO ORIENT. D 80	REVOLVING ELBOW - D 80	2	n
CA94	4010601115	COPERCHIO SCATOLA MOLT. MEC 2-8000 CE	GEARBOX COVER - MEC 2-8000 CE	1	n
CA95	4060505000	PROTEZIONE ALBERO CE	SHAFT GUARD - CE	1	n
CA96	5050906006	TAPPO D 16x1.5 - DIN 908 -	PLUG - D 16X1.5	1	n
CA97	5050202007	RONDELLA D 16X20X1,5 ALLUMINIO	ALUMINIUM WASHER - D 16X20X1,5	1	n
CA100	4010401078	FLANGIA DI SUPPORTO DEC. PER GARDA	PUMP SUPPORT FLANGE - GARDA	1	n
CA101	5050207002	RONDELLA Ø 6	SMOOTH WASHER - Ø 6	3	n
CA102/G	4020607063	PIGNONE DEC. PER GARDA G - Z39 - M3	GARDA PINION G - Z39 - M3	1	n
CA102/GA	4020607064	PIGNONE DEC. PER GARDA GA - Z50 - M3	GARDA PINION GA - Z50 - M3	1	n
CA103	5050107026	VITE M 10X25 TCEI	SCREW - M 10X25 TCEI	6	n
CA106	5060100001	ASTA LIVELLO OLIO 18X55 MM	OIL LEVEL ROD - MM 18X55	1	n
CA108	5050107107	VITE M 6x10 TEF - FL/ZIGR 8.8 -	GALVANIZED SCREW - M 6X10 TEF	4	n
CA109	5050507011	ANELLO SEEGER D 80 I - DIN 472	CIRCLIP - D 80 I	1	n
CA110	4010007038	TUBO COLL.COMPRESS-RACC BALLAST 3,5-9000	BALLAST CONNECTOR - BALLAST 3500-9000	2	n
CA111	5040407005	RACCORDO CURVO M/M 1/2" GAS	CURVED CONNECTOR - M/M 1/2" GAS	2	n
CA112	4010007083	TUBO COLLEGAMENTO FILTRI BALLAST3,5-7500	BALLAST FILTER CONN. - BALLAST 3500-7500	2	n
CA114	4010007084	SOSTEGNO TUBI BALLAST BALLAST 3500-7500	HOSES SUPPORT - BALLAST 3500-7500	1	n
CA115	5050107122	VITE M 6X25 TE - 10,9	SCREW - M6X25 TE - 10,9	3	n



BALLAST 9000 -11000 -13500

<i>Articolo</i> (Article)	<i>Codice</i> (Code)	<i>Descrizione</i>	<i>(Description)</i>	<i>Q.ty</i>	<i>Um</i>
CA116	5050107109	VITE M 10X25 TEF - DIN 6921 ISO 8100	SCREW - M 10X25 TEF - DIN 6921 ISO 8100	12	n
CA117	5050107108	VITE M 8X25 TEF - DIN 6921 ISO 8100	SCREW - M 8X25 TEF - DIN 6921 ISO 8100	8	n
CA118	5030210063	ANELLO TENUTA OR 177.47X2.62 - GAR. 9-13	SEAL RING - OR 177.47X2.62 MEC 9-13500/G	1	n
CA119	4010601153	COPERCHIO ANTERIORE MEC 5-13500 /P-AL	FRONT COVER - MEC 5-13500/P AL	1	n
CA122	4020507013	INGR. CON ALBERO MEC65-11000/HM Z53-M2,5	GEAR WITH SHAFT MEC6,5-11000/HM Z53-M2,5	1	n
CA125	4011707041	ANELLO DI RIDUZ. PER MOT. IDR. G.3	CENTERING RING FOR HYDR. MOTOR - G.3	1	n
CA126	4030108046	GUARN. SUPP. MOTORE IDR. G.3 / 3,5	HYDR. MOT. SUPP. GASKET - G. 3 /3.5	1	n
CA127	5050903003	TAPPO D 1/8" - DIN 906	PLUG - D 1/8"	2	n
CA130	4020607065	PIGNONE BALLAST 3500-7500/HM Z23-M2,5	PINION - Z23-M2,5 BALLAST 3500-7500/HM	1	n
CA144	5050107204	VITE M 12X35 TCEI - INOX	SCREW - M 12X35 TCEI INOX	2	n
CA154	5050107125	VITE M10X110 TCEI	SCREW - M10X110 TCEI	1	n
CA155	4020107028	PRESA CALETTATA FORO Ø32 CH.10 - Ø1"3/8	SPLINED HUB HOLE Ø32 - KEY 10 - Ø 1" 3/8	1	n
CA156	4010601101	COPERCHIO ANTERIORE / D - CE	FRONT COVER / D - CE	1	n
CA157	5050707031	CHIAVETTA 10X8X40	KEY - 10X8X40	1	n
CA158	5030300032	PARAOLIO 45X60X10	OIL SEAL - 45X60X10	1	n
CA159	5050207034	RONDELLA DI SICUREZZA Ø10	SECURITY WASHER - Ø10	1	n
CA165	5040303030	VALVOLA UNIDIREZIONALE D 3/4" BALLAST	UNIDIRECTIONAL VALVE D 3/4" BALLAST	2	n
CA166	5080005004	FILTRO ARIA VALV.UNID.3/4"	AIR FILTER - ONE-WAY VALVE 3/4"	2	n
CA174/A	6080200219	MOTORE IDR. KM 30.27	HYDRAULIC MOTOR KM 30.27	1	n
CA174/B	6080200056	MOTORE IDR. KM 30.43	HYDRAULIC MOTOR KM 30.43	1	n
CA174/C	6080200057	MOTORE IDR. KM 30.51	HYDRAULIC MOTOR KM 30.51	1	n



BALLAST 9000 -11000 -13500

<i>Articolo</i> (Article)	<i>Codice</i> (Code)	<i>Descrizione</i>	<i>(Description)</i>	<i>Q.ty</i>	<i>Um</i>
CA175	5050107054	VITE M 10X35 TE	SCREW - M 10X35 TE	4	n
CA192	5050207004	RONDELLA - D 10	SMOOTH WASHER - D 10	4	n
CA193	4010801043	MANIGLIA CON ATTACCO QUADRATO	HANDLE SQUARE CONNECTION	1	n
CA194	5050300016	DADO AUTOB. M 10X1,5 VARGAL UNI 9319	SELF-LOCKING NUT - M 10X1 VARGAL	1	n
CA195	5050207008	RONDELLA TRANCIATA D 10X40	BLANK WASHER - D 10X40	1	n
CA196	4012007015	MOLLA PIATTELLO BALLAST-AIDA	SPRING FOR POPPET VALVE BALLAST-AIDA	1	n
CA197	4011707114	GUIDA PIATTELLO BALLAST-AIDA	GUIDE FOR POPPET VALVE BALLAST-AIDA	1	n
CA198	4010401085	FLANGIA SUPPORTO PIATTELLO BALL.3,5-7500	FLANGE SUPPORT CHECK VALVE-BALL3,5-7500	1	n
CA199	4010006033	PIATTELLO COMPLETO BALLAST3,5-4,5-6-7500	POPPET VALVE -BALLAST3500-4500-6000-7500	1	n
CA200	4030109061	GUARN. FERMO PIATTELLO BALLAST 3,5-7500	POPPET V. LOCK GASKET - BALLAST 3,5-7500	1	n
CA211	4010601160	COPERCHIO SCATOLA MOLT. HM MEC 2-8000	GEARBOX COVER - MEC 2-8000 HM	1	n
CA212	5020400043	MOTORE IDRAULICO ORBITALE 100 CC	ORBITAL HYDRAULIC MOTOR 100 CC	1	n
CA213/A	6010201092	KIT REVISIONE POMPA BALLAST 3500	REBUILD KIT - BALLAST 3500	1	n
CA213/B	6010201093	KIT REVISIONE POMPA BALLAST 4500	REBUILD KIT - BALLAST 4500	1	n
CA213/C	6010201094	KIT REVISIONE POMPA BALLAST 6000	REBUILD KIT - BALLAST 6000	1	n
CA213/D	6010201084	KIT REVISIONE POMPA BALLAST 7500	REBUILD KIT - BALLAST 7500	1	n



BALLAST 9000 -11000 -13500

<i>Articolo</i> (Article)	<i>Codice</i> (Code)	<i>Descrizione</i>	<i>(Description)</i>	<i>Q.ty</i>	<i>Um</i>
		LUBRIFICAZIONE FORZATA	FORCEED LUBRICATION		
LF8	4010006002	GIUNTO DI COLLEGAMENTO L.F.	CONNECTOR JOINT - L.F.	1	n
LF12/D	5040200003	RUBINETTO REGOLATORE OLIO 2 VIE X 180°	DRAIN COCK - 2 WAYS X 180°	1	n
LF12/S	5040200007	RUBINETTO REGOLATORE OLIO 2 VIE X 60°	DRAIN COCK - 2 WAYS X 60°	1	n
LF36	5040303029	RACCORDO PORTATUBO 1/8" GAS	CONNECTOR - 1/8" GAS	2	n
LF14	5080110002	TUBO IN GOMMA Ø5X10,5	RUBBER HOSE - Ø 5X10,5	0,21	m
LF15	5080110002	TUBO IN GOMMA Ø5X10,5	RUBBER HOSE - Ø 5X10,5	0,17	m
LF16	5080110002	TUBO IN GOMMA Ø5X10,5	RUBBER HOSE - Ø 5X10,5	0,4	m
LF20	5080110002	TUBO IN GOMMA Ø5X10,5	RUBBER HOSE - Ø 5X10,5	0,47	m
LF21	5050107005	VITE M 6X16 TE	SCREW - M 6X16 TE	3	n
LF22	5030210028	ANELLO DI TENUTA OR 2337	SEAL RING OR 2337	1	n
LF23	6080200001	POMPA LF MEC 2-13500	PUMP - LF MEC 2-13500	1	n
		LUBRIFICAZIONE AUTOMATICA	AUTOMATIC LUBRICATION		
LA1	4010601022	COPERCHIO POSTERIORE POMPA OLIO MEC LA	OIL PUMP SUPPORT BACK COVER - MEC L.A.	1	n
LA2	4010006002	GIUNTO DI COLLEGAMENTO	CONNECTOR JOINT	1	n
LA4	4030108011	GUARN. POMPA OLIO L.A.	OIL PUMP GASKET - L.A.	1	n
LA7	5050107005	VITE M 6X16 TE	SCREW - M 6X16 TE	5	n
LA12	5040303007	RACCORDO D 1/8"X6X90° RILSAN	CONNECTOR - D 1/8"X6X90° RILSAN	2	n
LA15	5040303008	RACCORDO D 1/8"X4X90° RILSAN	CONNECTOR - D 1/8"X4X90° RILSAN	4	n
LA20	5050812001	INGRASSATORE M 10X1	LUBRICATOR - M10X1	1	n



BALLAST 9000 -11000 -13500

<i>Articolo</i> (Article)	<i>Codice</i> (Code)	<i>Descrizione</i>	<i>(Description)</i>	<i>Q.ty</i>	<i>Um</i>
LA24	5030210028	ANELLO TENUTA OR 2337-85.34X1.78	SEAL RING - OR 2337	1	n
LA23	5050207002	RONDELLA Ø 6	SMOOTH WASHER - Ø 6	5	n
LA26	5050903001	TAPPO M 10X1 - DIN 906	PLUG M 10X1 - DIN 906	1	n
LA27	5050906001	TAPPO 1/4" GAS	TAPPO 1/4" GAS	1	n
LA28	5050202003	RONDELLA 1/4" GAS ALLUMINIO	ALUMINIUM WASHER - 1/4" GAS	1	n
LB5/D	5080200036	POMPA LA 2 MAND. AL DX IIS	OIL PUMP - LA 2 WAYS AL DX IIS	1	n
LB5/S	5080200038	POMPA LA 2 MAND. AL SX IIS	OIL PUMP - LA 2 WAYS AL SX IIS	1	n
LB12	5040303011	RACCORDO DRITTO D 1/8"X6 RILSAN	STRAIGHT CONNECTOR - D 1/8"X6 RILSAN	1	n
LA49	5080105004	TUBO LUBRIFICAZIONE D 2X4 - PTFE	LUBRICATION HOSE - D 2X4 - PTFE	0,29	m
LA50	5080105004	TUBO LUBRIFICAZIONE D 2X4 - PTFE	LUBRICATION HOSE - D 2X4 - PTFE	0,69	m
LA51	5080105003	TUBO LUBRIFICAZIONE D 4X6 - PTFE	SUCTION HOSE - D 4X6 - PTFE	0,26	m
LA52	4010007080	FASCETTA STRINGITUBO	HOSE CLAMP	1	n
CA210	6010207005	KIT GUARNIZIONI BALLAST 3500-4500-6000-7500	SEALS KIT BALLAST 3500-4500-6000-7500	1	n
CA4	4030108066	GUARN. FLANGIA MEC 3,5-7500	FLANGE GASKET - MEC 3,5-7500	2	n
CA13	5030210028	ANELLO TENUTA OR 2337-85.34X1.78POMPA LF	SEAL RING - OR 2337 LF PUMP	2	n
CA18	5030300042	PARAOLIO 48X62X10 DCV - FKM	OIL SEAL - 48X62X10 DCV - FKM	2	n
CA27	5030300005	PARAOLIO 35X62X10	OIL SEAL - 35X62X10	1	n
CA28	4030108006	GUARN. COPERCHIO SCAT. MOLT. MEC 2-8000	GEARBOX COVER GASKET - MEC 2-8000	1	n
CA39	4030109046	GUARN. COLLETTORE MEC 3,5-7500	MANIFOLD GASKET - MEC 3,5-7500	1	n
CA40	5030300007	PARAOLIO 30X40X7 TC	OIL SEAL - 30X40X7	1	n



BALLAST 3500-4500-6000-7500

<i>Articolo</i> (Article)	<i>Codice</i> (Code)	<i>Descrizione</i>	<i>(Description)</i>	<i>Q.ty</i>	<i>Um</i>
CA53	5030300002	PARAOLIO 35X52X10	OIL SEAL - 35X52X10	1	n
CA64	5030210019	ANELLO TENUTA OR 179	SEAL RING - OR 179	2	n
CA68	4030109027	GUARN. COPERCHIO COLL. MEC 5-8000 UL	MANIFOLD COVER GASKET - MEC 5-8000 UL	1	n
CA80	5030300013	PARAOLIO 55X68X8	OIL SEAL - 55X68X8	1	n
CA118	5030210063	ANELLO TENUTA OR 177.47X2.62	SEAL RING - OR 177.47X2.62	1	n
CA126	4030108046	GUARN. SUPP. MOTORE IDR. G.3 / 3,5	HYDR. MOT. SUPP. GASKET - G. 3 /3.5	1	n
CA158	5030300032	PARAOLIO 45X60X10	OIL SEAL - 45X60X10	1	n
CA200	4030109061	GUARN. FERMO PIATTELLLO BALLAST 3,5-7500	POPPET V. LOCK GASKET - BALLAST 3,5-7500	1	n
LA4	4030108011	GUARN. POMPA OLIO L.A.	OIL PUMP GASKET - L.A.	1	n
	5051107008	SPINA CILINDRICA D10X40FORO M6-DIN 6364B	CYLINDRICAL PIN - D 10X40 HOLE M6	2	n
CA213/A	6010201092	KIT REVISIONE POMPA BALLAST 3500	REBUILD KIT - BALLAST 3500		
CA210	6010207005	KIT GUARNIZIONI BALLAST 3500-4500-6000-7500	SEALS KIT BALLAST 3500-4500-6000-7500	1	n
CA7/A	4070113232	PALETTA LONG LIFE BALLAST 3500 205X43X6.5	LONG LIFE BLADE - BALLAST 3500 205X43X6.5	8	n
CA213/B	6010201093	KIT REVISIONE POMPA BALLAST 4500	REBUILD KIT - BALLAST 4500		
CA210	6010207005	KIT GUARNIZIONI BALLAST 3500-4500-6000-7500	SEALS KIT BALLAST 3500-4500-6000-7500	1	n
CA7/B	4070113233	PALETTA LONG LIFE BALLAST 4500 260X43X6.5	LONG LIFE BLADE - BALLAST 4500 260X43X6,5	8	n



BALLAST 3500-4500-6000-7500

<i>Articolo</i> (Article)	<i>Codice</i> (Code)	<i>Descrizione</i>	<i>(Description)</i>	<i>Q.ty</i>	<i>Um</i>
CA213/C	6010201094	KIT REVISIONE POMPA BALLAST 6000	REBUILD KIT - BALLAST 6000		
CA210	6010207005	KIT GUARNIZIONI BALLAST 3500-4500-6000-7500	SEALS KIT BALLAST 3500-4500-6000-7500	1	n
CA7/C	4070113234	PALETTA LONG LIFE BALLAST 6000 350X43X6.5	LONG LIFE BLADE - BALLAST 6000 350X43X6,5	8	n
CA213/D	6010201084	KIT REVISIONE POMPA BALLAST 7500	REBUILD KIT - BALLAST 7500		
CA210	6010207005	KIT GUARNIZIONI BALLAST 3500-4500-6000-7500	SEALS KIT BALLAST 3500-4500-6000-7500	1	n
CA7/D	4070113235	PALETTA LONG LIFE BALLAST 7500 430X43X6.5	LONG LIFE BLADE - BALLAST 7500 430X43X6,5	8	n
LUBR_OIL	5070200100	OLIO BATTIONI PAGANI POMPE (5LT)	BATTIONI PAGANI VACUUM PUMP OIL (5LT)	1	n



Battioni®
Pagani

Setting the pace since 1953

0	15.01.2018	1° EMISSIONE	PROG	R DT	AM
REV.	DATA	MOTIVO	PREPARATO	APPROVATO	AUTORIZZATO



Battioni®
Pagani

Setting the pace since 1953

Via Cav. Enzo Ferrari, 2
43058 Ramoscello di Sorbolo (PR) - Italy

Ph. +39 0521 663203

Fax +39 0521 663206



www.bapag.it
info@bapag.it

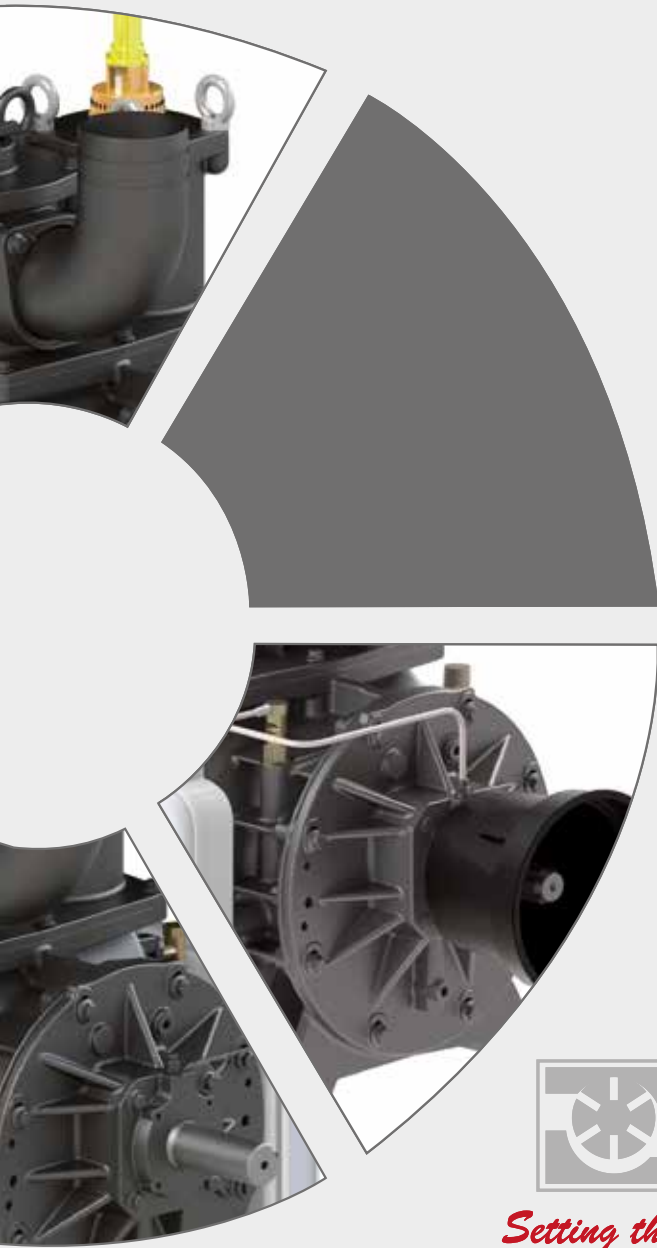

- IT** MANUALE ISTRUZIONI
PER L'USO E LA MANUTENZIONE
- GB** INSTRUCTION MANUAL FOR
USE AND MAINTENANCE
- FR** NOTICE D'EMPLOI
ET D'ENTRETIEN
- DE** GEBRAUCHS-UND
WARTUNGSANLEITUNGEN
- ES** MANUAL DE INSTRUCCIONES
DE USO Y MANTENIMIENTO
- PT** MANUAL DE INSTRUÇÕES PARA
USO E MANUTENÇÃO
- PL** PODRĘCZNIK INSTRUKCJI
OBSŁUGI I KONSERWACJI



Battioni®
Pagani

Setting the pace since 1953



NL HANDLEIDING VOOR HET
GEBRUIK EN HET ONDERHOUD

ZH 说明手册使用和维护

AR تامي لعت لي لد
ة ناي صل او م ادخت س ال ا
ة خض م ة لس لس ل

BALLAST



BALLAST 3500 - 4500 - 6000 - 7500 - 9000 - 11000 - 13500

Predisposition for overpressure valve
Predisposizione per valvola di sovrappressione
Vorbereitung für Überdruckventil

Kit Aluminum Final Air Filter
Kit filtro aria alluminio
Saugfilter Satz

Forced lubrication pump as standard (automatic lubrication on request)
Pompa di lubrificazione forzata di serie (lubrificazione automatica a richiesta)
Druckschmierung als Serie (Automatische Schmierung auf Anfrage)

Temperature indicator
Rilevatore di temperatura
Temperaturdedektor

160° C Irreversible indicator
Indicatore Irreversibile 160° C
irreversibel Anzeiger 160°C



Nr. 8 Long Life Blades as standard Heat-resistant blades of special material as standard
Nr.8 Palette "long life" resistenti al calore di serie
Nr. 8 Hitzebeständigen Lamellen aus Spezialmaterial als Serie



Extend Oil level indicator
Indicatore livello olio esterno
Ölstandsanzeige

Air injection cooling
Iniezione aria di raffreddamento
Injektion der Luftkühlung

Compression and thrust rings for bearings
Anello di compensazione
Ausgleichsring

Selector vacuum - pressure
Selettore Vuoto - Pressione
Wähler von Vakuum/Druck



CPS - CRASH PROTECTION SYSTEM

Sliding Flanges to avoid breakages of the body and rotor during vanes crashes

Flange con asole di scorrimento in caso di ingresso materiale o rottura palette
Flansche mit Slotsblättern falls Materialschmierung oder Palettenbruch



Flange-housing alignment control

Tacca di allineamento flangia - corpo
Ausrichtmarke der Flanschgehäuse



Blades inspection hole

Foro ispezione palette
Bohrung für Lamellen Prüfung

Vaness inspection hole with max wearing indicator

Tacca per rilevamento usura palette
Ausrichtmarke für die Abnutzung der Palette





BALLAST 16000

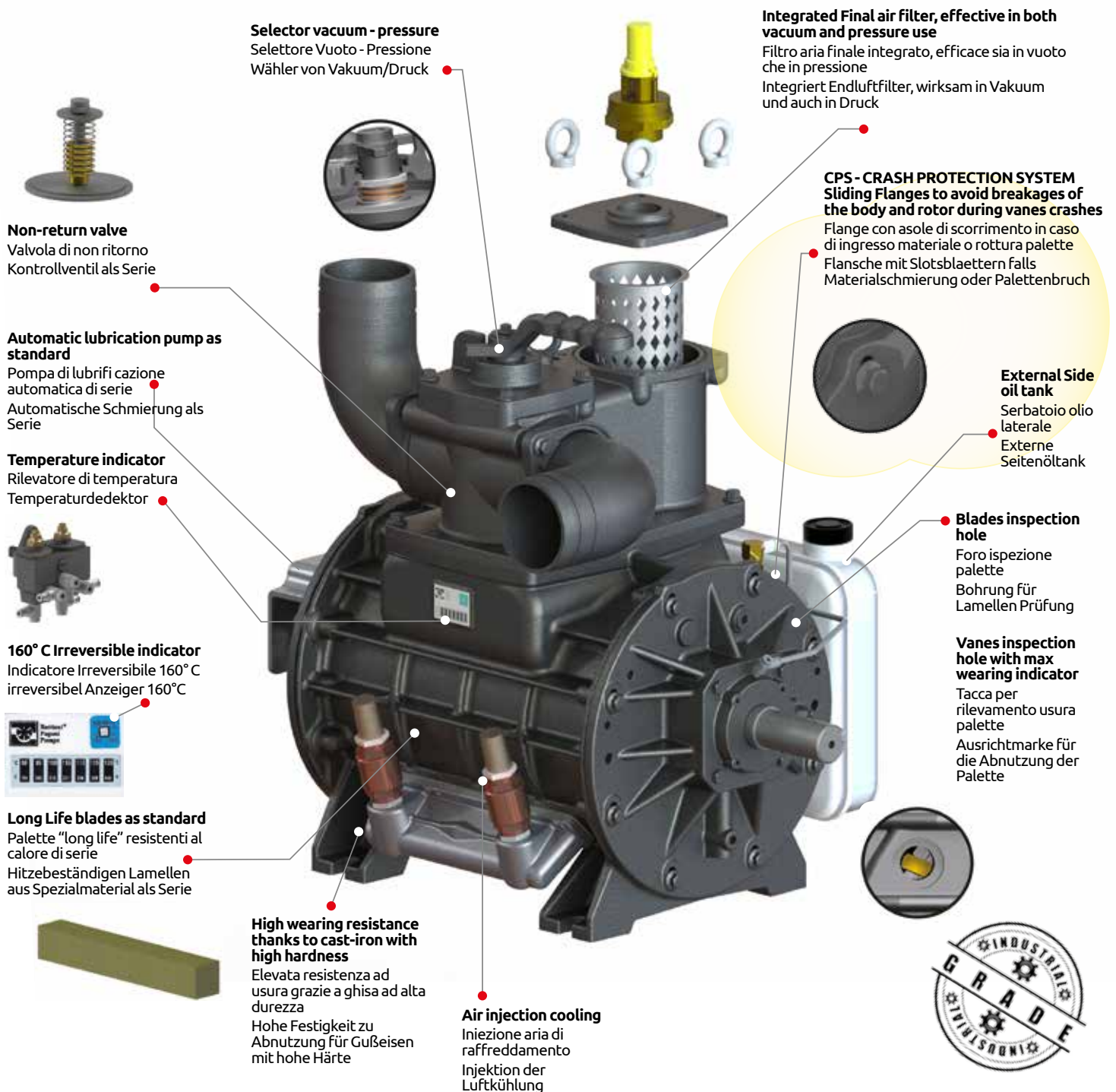

Selector vacuum - pressure
Selettore Vuoto - Pressione
Wähler von Vakuum/Druck

Integrated Final air filter, effective in both vacuum and pressure use
Filtro aria finale integrato, efficace sia in vuoto che in pressione
Integriert Endluftfilter, wirksam in Vakuum und auch in Druck

CPS - CRASH PROTECTION SYSTEM
Sliding Flanges to avoid breakages of the body and rotor during vanes crashes
Flange con asole di scorrimento in caso di ingresso materiale o rottura palette
Flansche mit Slotsblättern falls Materialschmierung oder Palettenbruch

External Side oil tank
Serbatoio olio laterale
Externe Seitenöltank

Blades inspection hole
Foro ispezione palette
Bohrung für Lamellen Prüfung

Vaness inspection hole with max wearing indicator
Tacca per rilevamento usura palette
Ausrichtmarke für die Abnutzung der Palette

Air injection cooling
Iniezione aria di raffreddamento
Injektion der Luftkühlung

High wearing resistance thanks to cast-iron with high hardness
Elevata resistenza ad usura grazie a ghisa ad alta durezza
Hohe Festigkeit zu Abnutzung für Gußeisen mit hohe Härte

Non-return valve
Valvola di non ritorno
Kontrollventil als Serie

Automatic lubrication pump as standard
Pompa di lubrificazione automatica di serie
Automatische Schmierung als Serie

Temperature indicator
Rilevatore di temperatura
Temperaturdedektor

160° C Irreversible indicator
Indicatore Irreversibile 160° C
irreversibel Anzeiger 160°C

Long Life blades as standard
Palette "long life" resistenti al calore di serie
Hitzebeständigen Lamellen aus Spezialmaterial als Serie



INTRODUCTION

The Battioni Pagani® rotary blades vacuum pumps were designed and constructed in compliance with the EEC safety regulations and were assessed for risks according to the standard UNI EN ISO 12100:2010; in particular they are in conformity with directive 2006/42/CE and subsequent modifications and additions.

Since the design of this pump complies with the definition of a machine as contained in the Machinery Directive 2006/42/EC, the pump bears the CE mark on its identification plate. It should be noted, however, in relation to its use and to the purpose of the supply that provides for the installation by the purchaser (without motive power), that Battioni Pagani® disclaims any liability as a result of failure to follow the instructions contained in the user and maintenance manual.

This manual contains the Declaration of CE conformity and all the instructions required by users, and by the manufacturers of plant systems, for using our products safely. As a result, the manual must always be kept near the rotary blades vacuum pump.



This danger symbol in the manual means that important instructions relating to safety are being provided. Operators are the first recipients of this information and are responsible for compliance, not only in relation to themselves, but also in relation to other persons exposed to the risks associated with use.

The descriptions and illustrations in this manual are purely indicative.

The manufacturer reserves the right to make any type of change to this manual at any time.

WARRANTY

At the moment of receiving the Rotary blades vacuum pump check that it is complete with all its parts.

Any anomalies or missing parts must be notified within 8 days of receipt of the product.

The Supplier guarantees that the product sold is free from defects and undertakes to repair or, by final decision, to replace the faulty parts only if the defects are clearly attributed to the manufacturing process or to the materials used. In any case the costs of labour, travel and transport, and any customs expenses, shall be paid by the Purchaser. The vendor is not obliged to pay damages except in the case of fraud or serious offence. All parts subject to normal wear are excluded from the guarantee. The guarantee will cease to be valid if:

- the faults reported are the result of accidents or obvious carelessness or negligence by the Purchaser,
- the parts have been modified, repaired or fitted by persons not authorised by the vendor,
- the failures and breakages have been caused by use that is unsuitable or heavier than that provided for by the vendor,
- the Purchaser has failed to make the payments as agreed under the contract.

The warranty rights of the Purchaser are invalidated where the same does not report to the Vendor any defects within 8 days of discovery, notwithstanding the provisions of art. 1512 of the Italian Civil Code. The Vendor reserves the right to make changes or improvements to its products without any obligation to make such changes or improvements to the units already previously produced and/or delivered. The Vendor reserves the right to make changes or improvements to his/her products without being obliged to make the same changes or improvements to the units already produced and/or delivered previously.

Thank you for choosing Battioni Pagani®.

Battioni Pagani®



COMPULSORY SAFETY SIGNS THAT THE MANUFACTURER OF THE SYSTEM MUST DISPLAY IN THE WORK PLACE AND AROUND THE ROTARY BLADES VACUUM PUMP

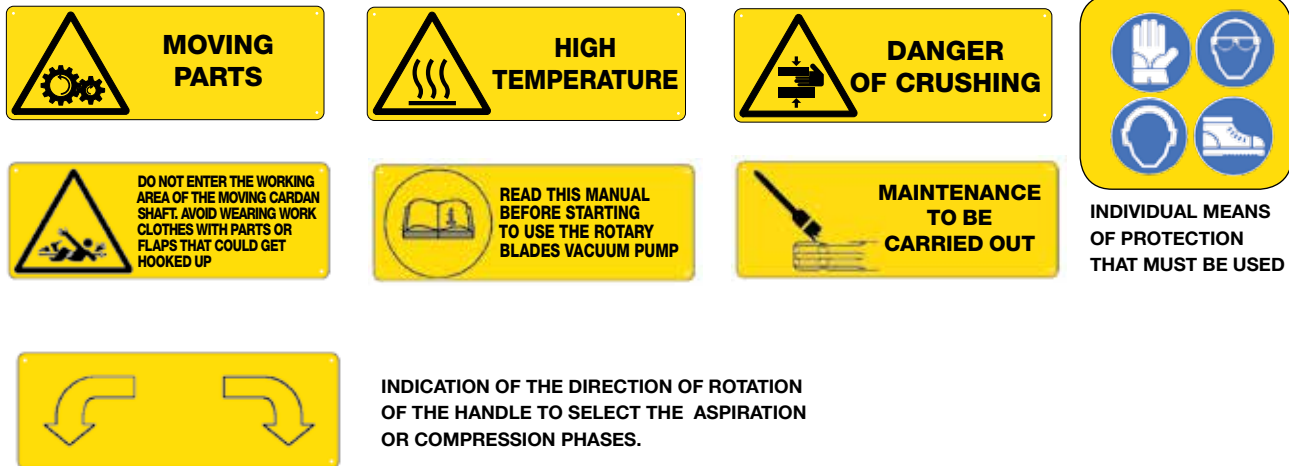

CONDITIONS AND LIMITS OF USE – LIST OF DANGERS

In the Common Market countries, the installation must comply with directive 2006/42/CE and subsequent modifications, while in the other countries it must comply with the safety regulations of the country.

This Rotary blades vacuum pump has been designed to create a vacuum or pressure inside a tank connected to it.

Under no circumstances must liquids, dust or any kind of solid matter enter the Rotary blades vacuum pump because they could cause it to break. Therefore it is necessary to equip the system with safety valves.

The use of the Rotary blades vacuum pump for any purpose other than that specified above is absolutely forbidden, not provided for by the manufacturer and therefore highly dangerous.

Do not use the Rotary blades vacuum pump to handle flammable and/or explosive liquids and materials or for materials that give off flammable gasses.

Do not use the rotary blades vacuum pump in a potentially explosive atmosphere.

Never remove the guards fitted on the Rotary blades vacuum pump and always check their efficiency every time the machine is used.

Any work on the machine must be carried out while it is not running.



Failure to comply with the instructions provided in this manual may result in the following dangers:

- Danger of being crushed by the rotary blades vacuum pump mass during handling and transportation;
- Danger of becoming entangled in the shaft transmission parts if the necessary guards are removed;
- Heat dangers due to the temperatures that can be reached by the rotary blades vacuum pump;
- Acoustic danger due to the noise generated and to failure to use personal means of protection;
- Danger of severing for the operator during testing with the suction and delivery tubes detached from the pump;
- Danger of abrasion due to the shaft of the hydraulic pump support if the rotary blades vacuum pump is being operated with the hydraulic pump disassembled;
- Danger of projection of fluid and solid materials owing to a serious breakage of the rotary blades vacuum pump.



SUMMARY

INTRODUCTION	30
WARRANTY	30
OBLIGATORY SAFETY SIGNS TO BE DISPLAYED IN THE WORK PLACE AND IN THE VICINITY OF THE IN THE WORKPLACE AND AROUND THE ROTARY BLADES VACUUM PUMP	31
CONDITIONS AND LIMITS OF USE – LIST OF DANGERS	31
SUMMARY	32
GENERAL INFORMATION	34
1 - VERSIONS OF THE BALLAST ROTARY BLADES VACUUM PUMP	34
1.1 IDENTIFICATION LABEL	35
INSTRUCTIONS FOR USE AND MAINTENANCE	36
2 - PACKAGING, STORAGE, HANDLING AND TRANSPORTATION	36
2.1 PACKAGING	36
2.2 STORAGE.....	36
2.3 HANDLING AND TRANSPORTATION.....	36
3 - ASSEMBLY, FITTING, INSTALLATION, DISASSEMBLY, RE-FITTING	36
3.1 INSTALLATION DIAGRAM.....	37
3.2 INSTALLATION DIAGRAM DUAL OUTPUT BALLAST 9000-11000-13500.....	37
3.3 ASSEMBLY AND FITTING – INSTALLATION	37
3.4 HYDRAULIC DIAGRAM (VERSION /H)	38
3.5 INSTRUCTIONS FOR USE AND MAINTENANCE OF THE HYDRAULIC MOTOR.....	39
3.6 UNINSTALLING.....	41
3.7 SDISASSEMBLY	41
3.7.1 Back disassembly.....	41
3.7.2 Front disassembly BALLAST 3500 - 4500 - 6000-7500 - 9000 - 11000 - 13500.....	42
3.7.3 Front disassembly BALLAST 16000.....	42
3.8 REASSEMBLY - REINSTALLING.....	43
3.8.1 Refitting of the back.....	43
3.8.2 Refitting of the replacement BALLAST 3500 - 4500 - 6000-7500 - 9000 - 11000 - 13500 manifold.....	43
3.8.3 Refitting of the BALLAST 16000 manifold	43
3.8.4 Refitting of the front.....	44
3.8.5 Correct positioning of the reversing gear BALLAST 3500 - 4500 - 6000-7500 - 9000 - 11000 - 13500.....	44
3.8.6 Correct positioning of the reversing gear BALLAST 16000	45
4 - ROTATION DIRECTION REVERSAL	45
5 - START-UP	46
5.1 DIRECTION OF ROTATION.....	46



6 - SET-UP OF THE LUBRICATION SYSTEM	46
6.1 FORCED LUBRICATION	46
6.2 AUTOMATIC LUBRICATION.....	46
6.3 RECOMMENDED OIL	46
6.3.1 Under no circumstances use the following brands of oil	47
6.3.2 Gearbox oil.....	47
6.3.3 Comparison table of the major brands of mineral oil	47
6.4 OIL LEVEL.....	47
6.5 LUBRICATION OIL QUANTITY	48
6.6 LUBRICATION OIL ADJUSTMENT	49
7 - OVERPRESSURE AND VACUUM ADJUSTMENT VALVES	49
8 - TESTING AND RUNNING IN.....	50
8.1 TESTING	50
8.2 RUNNING IN.....	50
9 - START, OPERATION, STOP	51
9.1 START	51
9.2 OPERATION.....	51
9.3 STOP	52
9.4 CONTROL DEVICES	52
9.5 TEMPERATURE INDICATOR (THERMO TAPE)	52
9.6 BALLAST CAP VALVE	52
9.7 BALLAST INTEGRATED AIR FILTER 16000.....	52
9.8 CRASH PROTECTION SYSTEM.....	53
9.9 BALLAST COOLING AIR FILTERS	53
9.10 FLUSHING KIT BALLAST	53
9.11 PROTECTIVE DEVICES ADOPTED	53
9.12 INDIVIDUAL MEANS OF PROTECTION TO BE USED.....	53
10 - TROUBLESHOOTING	54
11 - MAINTENANCE, INSPECTIONS AND CHECKS, REPAIRS, TECHNICAL ASSISTANCE	55
11.1 CLEANING	55
11.1.1 Washing of the body.....	55
11.1.2 Washing of the oil tank.....	55
11.1.3 Washing and cleaning of the valves.....	55
11.2 CHECKING OF VALVES.....	55
11.3 INSPECTION AND REPLACEMENT OF THE BLADES	55
11.3.1 "Long life" blades general information	55
11.3.2 BALLAST blades inspection.....	56
11.3.3 Replacement of blades.....	56
11.3.4 Blade sizes.....	56
11.4 REPLACEMENT OF GEARS (VERSION M - MA / K - KA).....	57
11.5 TECHNICAL ASSISTANCE.....	57
11.6 PERIODIC MAINTENANCE.....	57
12 - PUTTING OUT OF SERVICE AND DEMOLITION.....	57
TECHNICAL DATA	282

GENERAL INFORMATION

The BALLAST series rotary blades vacuum pumps were designed and manufactured to allow their use in continuous service at -0.70 vacuum bar, thanks to a cooling system for air injection at ambient temperature which, after passing through a filter and with the resistance of a non-return valve, enters the compression side, decreasing the internal temperature.

The intended use is semi-industrial, suitable for all applications that do not require the exceeding of substantial and consistent hydrostatic pressure and consequently of a very high degree of vacuum but which require a longer operation time compared to traditional use.

1 - VERSIONS OF THE ROTARY BLADES VACUUM PUMP

The rotary blades vacuum pump can be supplied in the following versions:

SERIES	M	MA	P	D	H	HM	K	KA	G	GA
BALLAST 3500/4500/6000/7500	O	-	O	O	O	O	-	-	O	O
BALLAST 9000/11000/13500	O	O	O	O	O	-	-	-	O	O
BALLAST 16000	O	O	O	O	O	-	O	O	O	O

- Not available O Available

VERSION .../ M – VERSION .../MA (with gearbox)

ROTATION
LEFT



- ... / M the PTO is driven via a cardan shaft at 540 rpm. The version is recognisable by the gearbox at the front of the rotary blades vacuum pump and by the identification label.
- ... / MA the PTO is driven via a cardan shaft at 1000 rpm. The version is recognisable by the gearbox at the front of the rotary blades vacuum pump and by the identification label.

VERSION .../ P (for pulley application)

ROTATION
RIGHT



UPON REQUEST
ROTATION
LEFT

- ... / P the power take-off is driven via a pulley and belts. The version can be recognised by the cylindrical shaft with key of the power take off and by the plate, ... / P = pulley application.

VERSION .../ D (direct drive)

ROTATION
LEFT



UPON REQUEST
ROTATION
RIGHT

- ... / D the power take-off is driven via a cardan shaft that is directly connected to the splined hub. This version can be recognised by the splined hub placed at the front of the rotary blades vacuum pump and by the identification plate, .../D = direct drive



VERSION .../H (for hydraulic drive)

ROTATION
RIGHT



- ... / **H** the power take-off is driven via a gears hydraulic motor. This version can be recognised by the hydraulic motor support placed at the front and by the identification plate, .../H = hydraulic drive.

VERSION .../K – VERSION .../KA (with multiplier and hydraulic pump support)

ROTATION
LEFT



- .../ **K** the PTO is driven via cardan shaft at 540 rpm and is equipped to operate a group 2 or group 3 pump. The version is recognisable from the hydraulic pump support and from the identification plate.
- .../ **KA** the PTO is driven via a cardan shaft at 1000 rpm and is equipped to operate a group 2 or group 3 hydraulic pump. The version is recognisable from the hydraulic pump and from the identification plate.

VERSION .../G – VERSION .../GA (Rotary blades vacuum pump for GARDA and GARDA EVO group)

ROTATION
RIGHT



- ... / **G** pump version for rotary blades vacuum pump that is applied on the GARDA or GARDA EVO group; it cannot be used separately. The version is recognisable from the outer pinion on the front and from the identification plate, ... / G = application for GARDA or GARDA EVO.
- ... / **GA** version of the rotary blades vacuum pump that is applied on the GARDA or GARDA EVO group at 1000 rpm; it cannot be used separately. The version is recognisable from the outer pinion on the front and from the identification plate, AGRI/GA = application for GARDA or GARDA EVO at 1000 rpm.

Versions... /**K** and ... /**KA** have been designed so that they can be used to actuate the hydraulic accessories (gate valves, draft tube, support base etc.) on the tank car because in many cases the hydraulic pump on the tractor does not have sufficient oil flow rate for all the movements. With this application all the work may be carried out from the tractor cabin by operating only one distributor

1.1 IDENTIFICATION LABEL

Each rotary blades vacuum pump is provided with an identification plate on which is indicated:

- rotary blades pump model
- serial number
- production year
- max relative pressure
- max vacuum
- max absorbed power
- max r.p.m.
- max rate of flow
- CE mark
- weight of pump

IDENTIFICATION PLATE WITH PROTECTIVE FILM FOR PAINTING



Every identification plate is protected by a special sky-blue colour film, to remove after painting. This film has been introduced to guarantee the tracing of the pump for warranty purposes.



INSTRUCTIONS FOR USE AND MAINTENANCE

2 - PACKAGING, STORAGE, HANDLING AND TRANSPORTATION

2.1 PACKAGING

The rotary blades vacuum pumps are supplied without packaging. On request the following packaging can be used:

- wooden base and shrink-wrap;
- wooden crates and shrink-wrap for shipment by sea or air;

2.2 STORAGE

In order to preserve the rotary blades vacuum pump correctly, it must be stored:

- under cover, sheltered from adverse weather conditions;
- resting horizontally on its four feet.

The rotary blades vacuum pumps are lubricated during testing at our factory with special oil that ensures lubrication of the various internal components for approx. 6 months. In the event of subsequent storage it is advisable to wash the inside of the body with oil and diesel oil (as stated in this manual).

2.3 HANDLING AND TRANSPORT

To view the data concerning the mass of the BALLAST pump see the technical annexes.



*only be moved using equipment with adequate load and range capacity.
Slung through metal hooks to be inserted into the relevant grip holes, or sling; lifted by forklift truck (if on pallet), bridge crane, crane or hoist.*

If on pallets, loosen the screws holding the 4 feet of the BALLAST pump to the pallet.

For safety reasons, use a sling or chain to lift the pump,

together with the eyebolt.

Pass the sling or chain below the BALLAST pump, between the support feet

Hook the sling or chain to the lifting equipment.

The rotary blades vacuum pump is provided with protection in accordance with the EC Directives in the part to be mounted by the installer using the screws provided.



3 - ASSEMBLY, FITTING, INSTALLATION, DISASSEMBLY, RE-FITTING

The procedures concerning the rotary blades vacuum pump versions .../G and .../GA are provided in the GARDA/GARDA EVOgroup manual.



When carrying out maintenance operations, inspections, checks or repairs it is advisable to wear the individual protective devices listed in this manual.

In the case of pump painting do not paint the identification plate, taps, oil sight glass, the oil level dipstick or the vent plugs.



All maintenance operations, inspections, checks and repairs should be carried out with the greatest care and with the tractor not running and the power take-off disconnected.



*It is essential to prevent sewage from entering the Rotary blades vacuum pumps.
The entrance of sewage would cause the blades and consequently the rotor to break.*

It is therefore necessary to equip the system with an overflow valve, “3”, and a safety overflow valve, “2”, between the rotary blades vacuum pump and the tank car (see Figure 1)



3.1 INSTALLATION DIAGRAM



- 1 - Pump
- 2 - Secondary shut-off valve
- 3 - Primary shut-off valve
- 4 - Silencer
- 5 - Motorized joint
- 6 - Swivel joint
- 7 - Stemgate
- 8 - Overpressure valve
- 9 - Depression valve

Figure 1

3.2 INSTALLATION DIAGRAM DUAL OUTPUT BALLAST 9000-11000-13500

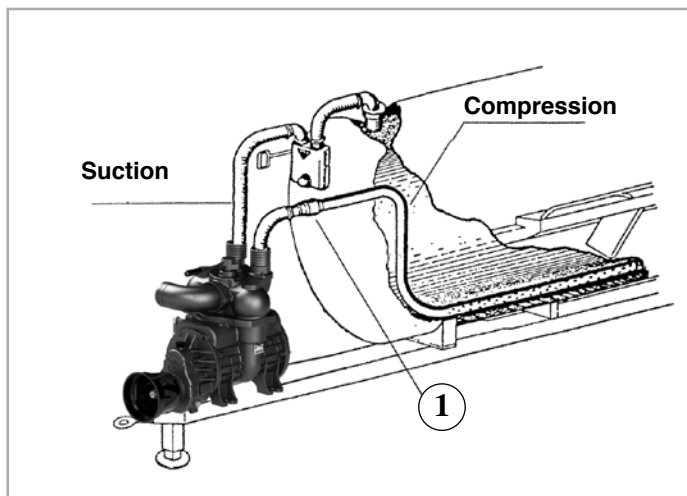

The Rotary blades vacuum pump can be used as a mixer by fitting, on request, a double outlet on the manifold (see Figure 2). In this case there will be the intake of a normal Rotary blades vacuum pump, but a perforated tube placed inside the tank car must be used for the compression.

When the handle is positioned on the compression phase, the air will be forced out through the holes in the tube so causing mixing of the previously loaded sewage (never exceed mixing of the previously loaded sewage (never exceed the maximum working absolute pressure of 2,5 bar) equal to 1,5 relative bar).

Figure 2



With this system, a check valve (1) must be fitted on the delivery tube to prevent the transfer of sewage inside the Rotary blades vacuum pump.

3.3 ASSEMBLY AND FITTING - INSTALLATION

The Rotary blades vacuum pump should be assembled and installed using the following procedure:

- 1) Assemble the Rotary blades vacuum pump horizontally with its feet facing downwards. The assembly position on the vehicle should be easy to access and be protected. A 5° maximum longitudinal slope of the vacuum/pressure blowers pump with respect to the horizontal plane must not be exceeded.
- 2) Bolt the Rotary blades vacuum pump using screws and nuts passing through the specially provided slots or holes in the feet;
- 3-M/K)** To install the .../M-K version Rotary blades vacuum pump, connect the cardan shaft at 540 r.p.m. of the tractor to the P.T.O. shaft of the Rotary blades vacuum pump.
- 3-MA/KA)** To install the .../MA-KA version Rotary blades vacuum pump, connect the cardan shaft at 1000 r.p.m. of the tractor to the P.T.O. shaft of the Rotary blades vacuum pump.



Do not exceed the maximum slope permitted for the cardan shaft.

3-P) To install the .../P version Rotary blades vacuum pump, attach a driven pulley to the shaft and fix it with the special screw located on the front of the shaft. The driven pulley may be fitted directly on the cylindrical shaft if the radial load is brought close to the bearing. Never transfer axial loads. Then connect the driven pulley to the driving pulley with the correct length of driving belts. The number and type of belts must be calculated according to the power to be transferred to the rotary blades vacuum pump. When this operation has been completed, the necessary guard must be installed to isolate the driving parts (pulleys and belts) and prevent access to them by the operators.

- The best tension is the lower one where the belt doesn't slide under max loading condition
- Check frequently the tension during first 24/48 hours of running phase
- The over-tension reduces the life of belt and bearing
- Keep belts free from any material which may cause sliding
- Check periodically the transmission. Set it when sliding

To check the tension on a normal transmission, do what follows:

- measure the length of free stretch (t)
- In the middle of free stretch of the belt (t) apply a force(perpendicular to free stretch) nought to bend the belt 1.6 mm per 100 mm in length of the free. For example, the decline of a free stretch of 1000 mm is 16 mm.
- Compare the force you have applied and measured through a instrument with data stated under our table. If the force is included between "minimum force" data, it means that the belt is not enough stretched. If the force exceeds "max force" data, it means that the belt is too stretched.

However, a new transmission can be initially tensioned to twice the value of "min strength" to allow normal adjustment of tension during operation.

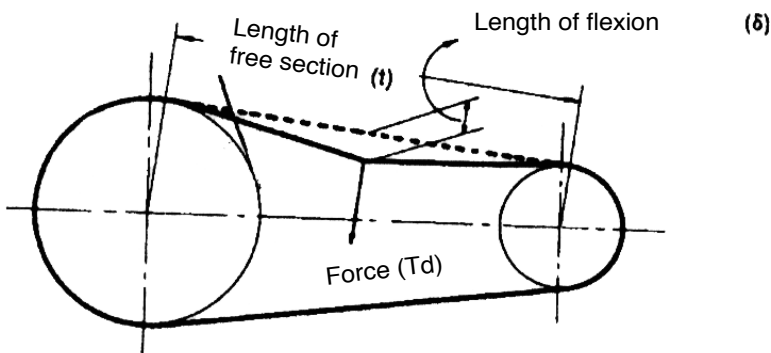

Section	Force	
	Min Kg.	Max Kg.
A	0.68	1.02
B	1.58	2.38
C	2.93	4.75
D	5.77	8.61
E	9.60	14.30

3-D) To install the .../D version rotary blades vacuum pump, connect the cardan shaft at 1000 rpm of the tractor to the P.T.O. shaft of the rotary blades vacuum pump.



Do not exceed the maximum slope permitted for the cardan shaft.

3-H) To install the rotary blades vacuum pump version ... / H, it is necessary to fit a hydraulic motor (European unification flanging, Group 3.5 FOR BALLAST 3500 - 4500 - 6000 - 7500 - 9000 - 11000 and Group 4 for BALLAST 13500-16000 on the PTO shaft and secure it, using the relevant screws, to the holder located at the front.

3.4 HYDRAULIC DIAGRAM (version / H)

The hydraulic system required for operation of the rotary blades vacuum pump version / H is schematised in the version with uni- and bi-directional motor shown below and the technical characteristics of the hydraulic motor in **Table 1**. Splining of the hydraulic motor is of the type DIN 5482 - Z=23 for the BALLAST series 13500-16000 and of the type DIN 5482 - Z=20 for the series BALLAST 3500 - 4500 - 6000 - 7500 - 9000 - 11000.

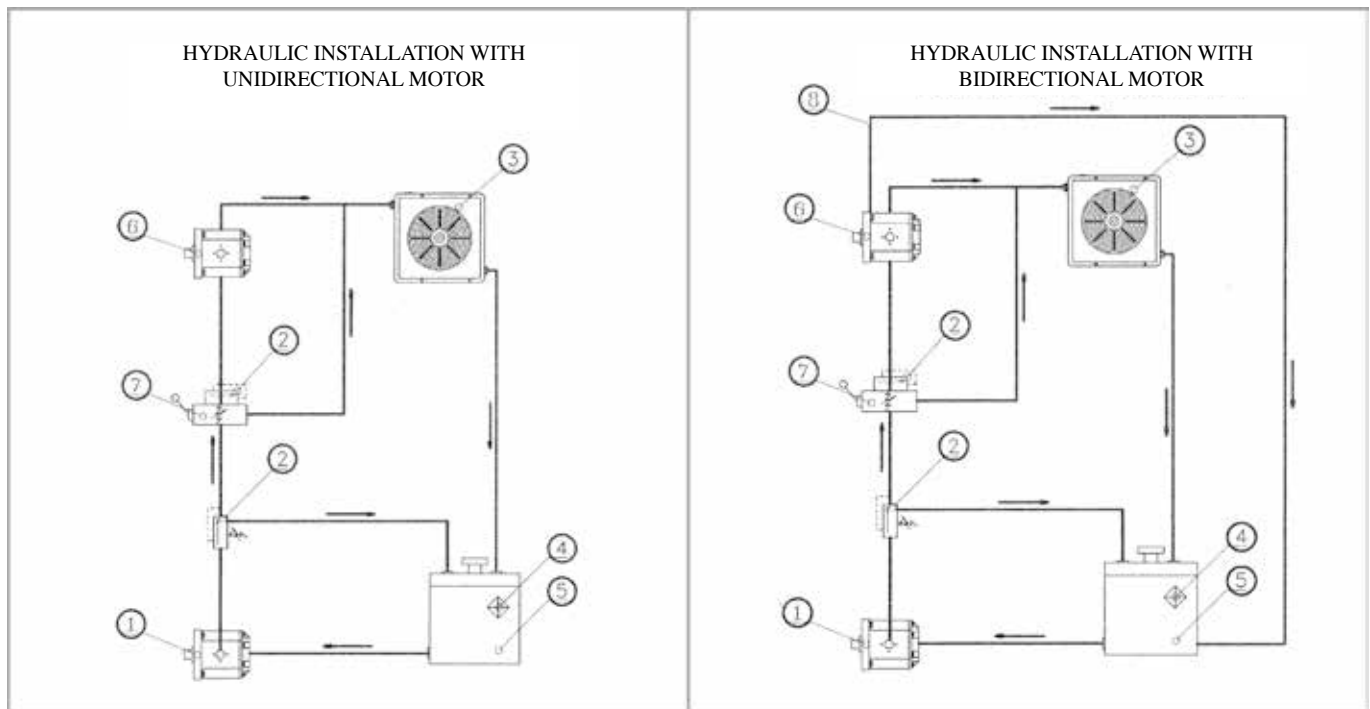

1 Hydraulic pump
2 Over-pressure valve
3 Radiator
4 Oil filter

5 Oil tank
6 Hydraulic motor
7 Distributor
8 Drainage

4) Then connect the intake/compression pipe of the tank car to the rotary blades vacuum pump tightening it to the adjustable elbow using metal clamping bands in relation to the diameter of the pipe.

3.5 INSTRUCTIONS FOR USE AND MAINTENANCE OF THE HYDRAULIC MOTOR

Make sure take the rotation of the unidirectional motor is the proper are for your system. Make sure take there is good linear matching between motor shift and power take off.

TANK. The tank capacity must be sufficient for the system's operating conditions (~ 3 times the amount of oil in circulation) to avoid overheating of the fluid. A heat exchanger should be installed if necessary. The intake and return lines in the tank must be spaced apart (by inserting a vertical divider) to prevent the return-line oil from being taken up again immediately.

LINES. The lines must have a nominal diameter which is at least as large as the openings of the engine and must be perfectly sealed. A length of flexible tubing is recommended to reduce the transmission of vibrations. All return lines must end below the minimum oil level, to prevent foaming.

FILTERS. We recommend filtering the entire system flow rate.

HYDRAULIC FLUID. Use hydraulic fluid conforming to the ISO/DIN standards. Avoid using mixtures of different oils which could result in decomposition and reduction of the oil's lubricating power.

DRAIN HOLE: in the bi-directional motors with drain hole, the hole must be connected to the oil tank through a hose of at least 22 mm of diameter. To avoid the forming of foam inside the tank, the hose must be connected below the minimum level.

STARTING UP. Check that all circuit connections are exact and that the entire system is completely clean. Insert the oil in the tank, using a filter. Bleed the circuit to assist in filling. Set the pressure relief valves to the lowest possible setting. Turn on the system for a few moments at minimum speed, then bleed the circuit again and check the level of oil in the tank. If the temperature difference between engine and fluid exceeds 10°C, rapidly switch the system on and off to heat it up gradually. Then gradually increase the pressure and speed of rotation until the pre-set operating levels as specified in the catalogue are attained.

PERIODICAL CHECKS – MAINTENANCE Keep the outer surface clean. Replace filters regularly to keep the fluid clean. The oil level must be checked and replaced periodically depending on the system's operating conditions.

RESOLUTION OF PROBLEMS: If the circuit is open (i.e. downstream of the engine there is the oil tank and not the pump) where the engine continues to rotate with the engine off, this is not a case of overpressure but of cavitation. To solve the problem, a uni-directional valve is required which would convey the oil, or part of it via calibration, from the engine delivery to its inlet in order to prevent the engine pumping air.

- The circuit is closed. There may be overpressure. To resolve the problem either install an overpressure relief valve, as we recommend in the attached system diagram, or a calibrated uni-directional valve that partly bypasses the engine. Compared to the first solution, the latter option is cheaper and less invasive on an existing system as it does not require an additional hole in the tank.

HYDRAULIC MOTORS							
Hydraulic Motor	Rotary blades vacuum pump	Max operating pressure (bar)	Displacement (cm ³ /r)	No. Rev/min (rpm)	Pressure (bar)	Pressure max hydraulic system (bar)	Dimension connector
MSA 125 SHA	BALLAST 3500/HM	1	125,7	540	80	175	G 1/2" - G 1/2"
MSA 125 SHA	BALLAST 4500/HM	1	125,7	540	105	175	G 1/2" - G 1/2"
MSA 125 SHA	BALLAST 6000/HM	1	125,7	540	135	175	G 1/2" - G 1/2"
MSA 125 SHA	BALLAST 7500/HM	1	125,7	540	155	175	G 1/2" - G 1/2"
KM 30.27	BALLAST 3500/H	1	26,7	1200	175	280	G 1" - G 3/4"
KM 30.43	BALLAST 4500/H	1	43,98	1200	135	250	G 1" - G 1"
KM 30.43	BALLAST 6000/H	1	43,98	1200	175	250	G 1" - G 1"
KM 30.51	BALLAST 7500/H	1	51,33	1200	170	230	G 1" - G 1"
KM 30.51-SO	BALLAST 9000	1	51,83	1200	195	230	G1"-G1"
KM 30.73-SO	BALLAST 11000	1	73,82	1200	145	180	G1"-G1 1/4"
KM 40.87-SO	BALLAST 13500	1	86,56	1200	145	280	G1 1/4"-G1 1/2"
	BALLAST 16000				210		G1 1/4"-G1 1/2"

Tabella 1



3.6 UNINSTALLING

The rotary blades vacuum pump must be disinstalled using the following procedure:

... D / M-MA / K-KA	.../P	.../C -GA	.../H
1) stop the PTO of the tractor.	1) stop the PTO of the tractor.	1) stop the PTO of the tractor.	1) stop the hydraulic system.
2) remove the cardan shaft from the power take-off of the rotary blades vacuum pump;	2) remove the drive belts;	2) remove the cardan shaft from the power take-off of the rotary blades vacuum pump;	2) remove the hydraulic connections to the motor.
3) remove the connection tube that unites the rotary blades vacuum pump to the tank car by loosening the metal clamp and sliding the tube from the sleeve;	3) remove the connection tube that unites the rotary blades vacuum pump to the tank car by loosening the metal clamp and sliding the tube from the sleeve;	3) remove the connection tube that unites the rotary blades vacuum pump to the tank car by loosening the metal clamp and sliding the tube from the sleeve;	3) remove the connection tube that unites the rotary blades vacuum pump to the tank car by loosening the metal clamp and sliding the tube from the sleeve;
4) remove any water or or air connections;	4) remove any water or or air connections;	4) remove any water or or air connections;	4) remove any water or or air connections;
5) remove the screws and disassemble the rotary blades vacuum pump.	5) remove the screws and disassemble the rotary blades vacuum pump.	5) remove the screws and disassemble the rotary blades vacuum pump.	5) remove the screws and disassemble the rotary blades vacuum pump.

ENGLISH

3.7 DISASSEMBLY

3.7.1 BACK DISASSEMBLY

BALLAST SERIES 3500-4500-6000-7500-9000-11000-13500

- 1) Remove the rear cover or oil pump (together with the connecting joint) from the flange;
- 2) Remove the seeger ring from the rear pin;
- 3) Remove the screws from the rear flange.
- 4) Screw two screws into the threaded extraction holes just until the flange can be removed;

BALLAST SERIES 16000

1. Close the oil cock placed on the tank
2. Remove the back cover with the lubrication pump (together with the connector joint) from the flange;
3. Remove the screws from the back flange;
4. Use two screws for screwing into the threaded extraction holes until the flange is removed;



3.7.2 FRONT DISASSEMBLY BALLAST 3500-4500-6000-7500-9000-11000-13500

.../D	... M-MA / K-KA	... / P	... / G-GA	... / H
1) Remove the front cover from the flange.;	1) Loosen the screws of the gearbox cover.	1) Remove the driven pulley and the key.	1) Unscrew the self-locking nut.	1) Disassemble the hydraulic motor from its support.
2) Remove the screws from the front flange;	2) Screw two screws into the threaded extraction holes to remove the cover.	2) Remove the front cover from the flange.	2) Remove the pinion using the extractor.	2) Disassemble the hydraulic motor support.
3) Screw two screws into the threaded extraction holes to remove the front flange	3) Remove the gear with splined shaft using an extractor if necessary.	3) Remove the screws from the front flange.	3) Remove the screws of the Garda/Garda Evo/Ledra coupling flange.	3) Remove the clamping screw located inside the connection sleeve.
	4) Unscrew the self-locking nut.	4) Screw two screws into the threaded extraction holes to remove the front flange.	4) Screw two screws into the threaded extraction holes to remove the Garda/Garda Evo/Ledra coupling flange.	4) Antriebsbuchse demontieren.
	5) Remove the pinion using the extractor.			5) Die Schrauben vom vorderen Flansch entfernen;
	6) Remove the screws from the gearbox.			6) Zwei Schrauben solange in die Abdrückgewinde einschrauben, bis sich der vordere Flansch entfernen lässt;
	7) Screw two screws into the two threaded extraction holes to remove the gearbox.			

3.7.3 FRONT DISASSEMBLY BALLAST 16000

.../D	... M-MA / K-KA	... / P	... / G-GA	... / H
1) Remove the front cover from the flange;	1) Loosen the screws of the gearbox cover.	1) Remove the driven pulley and the key.	1) Unscrew the self-locking nut.	1) Disassemble the hydraulic motor from its support.
2) Remove the screws from the front flange.	2) Screw two screws into the threaded extraction holes to remove the cover.	2) Remove the front cover from the flange.	2) Remove the pinion using the extractor.	2) Disassemble the hydraulic motor support.
3) Remove the seeger ring placed in front of the bearing;	3) Remove the gear with splined shaft using an extractor if necessary.	3) Remove the seeger from the front pin.	3) Remove the seeger from the front pin.	3) Remove the clamping screw located inside the connection sleeve.
4) Slide the rotor from the body;	4) Unscrew the self-locking nut.	4) Remove the screws from the front flange.	4) Remove the screws of the Garda/Garda Evo/Ledra coupling flange.	4) Disassemble the transmission sleeve.
5) Den Rotor mittels einer Presse vom vorderen Flansch entfernen.	5) Remove the pinion using the extractor.	5) Screw two screws into the threaded extraction holes to remove the front flange.	5) Screw two screws into the threaded extraction holes to remove the Garda/Garda Evo/Ledra coupling flange.	5) Remove the seeger from the front pin.
	6) Remove the seeger from the front pin.	6) Extract the rotor from the body together with the front flange.	6) Remove the rotor from the body together with the Garda/Garda Evo/Ledra coupling flange.	6) Remove the screws from the front flange.
	6) Remove the screws from the gearbox.	7) Disassemble the rotor from the front flange using a press.	7) Remove the rotor from the Garda/Garda Evo/Ledra coupling flange.	7) Screw two screws into the threaded extraction holes to remove the front flange.
	7) Screw two screws into the two threaded extraction holes to remove the gearbox.			8) Extract the rotor from the body together with the front flange.
	8) Slide the rotor from the body together with the gearbox.			9) Disassemble the rotor from the front flange using a press.
	9) Disassemble the rotor from the gearbox using a press.			



3.8 ASSEMBLY - REINSTALLATION



IMPORTANT: Before proceeding with any re-fitting, replace the gaskets of the opened parts.

3.8.1 REFITTING OF THE BACK

BALLAST SERIES 3500-4500-6000-7500-9000-11000-13500-16000

- 1) Remove the bearing from the rear flange;
- 2) Insert the two centring pins into the pump body;
- 3) Replace the seal on the flange;
- 4) While lining up the holes with the two pins, bring the rear flange and the pump body together;
- 5) Insert the 6 mounting screws into the slotted holes and tighten to $45 \div 55$ Nm;
- 6) Using a mallet, install the bearing on the flange;
- 7) Insert the seeger ring into the rear pin with the compensation ring;
- 8) Install the rear cover or oil pump (together with the connecting joint) back onto the flange;
- 9) Remove the centring pins.

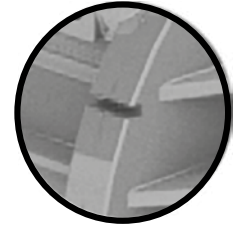

Figure A

The BALLAST pump is equipped with a system that allows the flange to slide, which prevents breakage if foreign bodies become lodged between the rotor and the pump body. (Except for version G-GA)

To benefit from this system, it is important to follow these instructions:

Before starting the pump, make sure the rotor has not dropped down accidentally. This can be accomplished by making sure the cut in the flange lines up with the cut machined into pump body (see figure A).

3.8.2 REFITTING OF THE BALLAST 3500-4500-6000-7500-9000-11000-13500 MANIFOLD

- 1) Replace the manifold gasket;
- 2) Position the manifold on the pump body;
- 3) Tighten the mounting screws on the manifold;
- 4) Insert the gear;
- 5) Fit the spring on the gear;
- 6) Fit the spacer on the gear spring;
- 7) Replace the gasket on the manifold cover;
- 8) Position the manifold cover on the manifold;
- 9) Tighten the mounting screws on the manifold cover;
- 10) Install the oil seal into its seat on the manifold cover;
- 11) Install the handle and tighten it using the screw provided;



3.8.3 REFITTING OF THE BALLAST 16000 MANIFOLD;

- 1) Replace the gasket on the manifold;
- 2) Position the manifold on the pump body;
- 3) Tighten the mounting screws on the manifold;
- 4) Insert the gear;
- 5) Fit the spring on the gear;
- 6) Fit the spacer on the gear spring;
- 7) Replace the O-ring on the manifold cover;
- 8) Position the manifold cover on the manifold;
- 9) Tighten the mounting screws on the manifold cover;
- 10) Install the oil seal into its seat on the manifold cover;
- 11) Install the handle and tighten it using the screw provided;
- 12) Fit the filter cartridge;
- 13) Replace the O-ring on the filter cover;
- 14) Place the filter cover on the manifold ;
- 15) Tighten the mounting screws of the filter cover;





3.8.4 REFITTING OF THE FRONT

.../M-MA-K-KA	.../P	.../D	.../H	... / G-GA
1) Remove the seeger ring;	1) Remove the seeger ring;	1) Remove the seeger ring;	1) Remove the seeger ring;	1) Remove the seeger ring;
2) Remove the bearing;	2) Remove the bearing;	2) Remove the bearing;	2) Remove the bearing;	2) Remove the bearing;
3) Replace the flange gasket;	3) Replace the seal on the flange;	3) Replace the seal on the flange;	3) Replace the seal on the flange;	3) Replace the flange gasket;
4) Insert the pins supplied in the body;	4) Insert the pins supplied into the body;	4) Insert the pins supplied into the body;	4) Insert the pins supplied into the body;	4) Insert the pins supplied in the body;
5) Attach the gearbox to the body with screws tightened to 45 ÷ 55 Nm;	5) Install the front flange onto the body using screws tightened to 45 ÷ 55 Nm;	5) Install the front flange onto the body using screws tightened to 45 ÷ 55 Nm;	5) Install the front flange onto the body using screws tightened to 45 ÷ 55 Nm;	5) Install the front flange onto the body using screws tightened to 45 ÷ 55 Nm;
6) Using a buffer, install the bearing onto the flange, install the compensation ring and install the seeger ring;	6) Using a buffer, install the bearing onto the flange, install the compensation ring and install the seeger ring;	6) Using a buffer, install the bearing onto the flange, install the compensation ring and install the seeger ring;	6) Using a buffer, install the bearing onto the flange, install the compensation ring and install the seeger ring;	6) Using a buffer, install the bearing onto the flange, install the compensation ring and install the seeger ring;
7) Install the spacer and mount the pinion on the shaft;	7) Refit the front cover back onto the flange;	7) Refit the front cover back onto the flange;	7) Reassemble the transmission sleeve on the rotary pin;	7) Install the spacer and mount the pinion on the shaft;
8) Fit the pinion fixing self-locking nut;	8) Remove the centring pins from the body.	8) Replace the splined plug.	8) Re-fit the hydraulic motor support;	8) Fit the pinion fixing self-locking nut;
9) Insert the gear in the bearing seat;		9) Remove the centring pins from the body.	9) Remove the centring pins from the body.	9) Insert the gear in the bearing seat;
10) Install the box cover;				10) Remove the centring pins from the body.
11) Fill the gearbox with oil;				
12) Remove the centring pins from the body.				

3.8.5 CORRECT POSITIONING OF THE REVERSING GEAR BALLAST 3500 - 4500 - 6000 - 7500 - 9000 - 11000 - 13500

To position the reversing gear correctly, follow the procedure below:

1. remove the handle;
2. remove the manifold cover;
3. check that the flat part of the reversing gear is placed at 45° with respect to the power take-off;
4. refit the manifold cover;
5. refit the handle.





3.8.6 CORRECT POSITIONING OF THE REVERSING GEAR BALLAST 16000

To position the reversing gear correctly, follow the procedure below:

1. remove the handle;
2. remove the manifold cover;
3. make sure that the stickers on the reversing gear are positioned as shown in the picture attached;
4. refit the manifold cover;
5. refit the handle.



4 - ROTATION DIRECTION REVERSAL – ROTARY BLADES VACUUM PUMP WITH FORCED OR AUTOMATIC LUBRICATION

If it is necessary to reverse the direction of rotation of a rotary blades vacuum pump with automatic lubrication, proceed as follows:

- remove the back cover and the right or left automatic lubrication pump (together with the connection joint) from the flange;
- remove the screws from the back flange;
- use two screws in the threaded extraction holes until the flange is removed;
- remove the screws from the front flange;
- extract the rotor from the body together with the front flange;
- rotate the body together with the manifold 180° on a horizontal level;
- replace two flange gaskets;
- slide the rotor in the body together with the front flange;
- tighten the six securing screws of the front flange to the body;
- disassemble the bearing and the seeger from the back flange;
- approach the back flange to the pump body, positioning it on a level with the securing holes;
- insert the six securing screws in the holes and tighten;
- assemble the bearing on the flange by means of a stopper and fit the seeger;
- re-assemble the back cover and replace the automatic lubrication pump DX or SX with another one with opposite direction of rotation (together with the coupling joint) to the flange.



In the case of a Ballast rotary blades vacuum pump with forced lubrication follow the same instructions as specified above but the lubrication pump must not be replaced as it is bi-directional.

5 - START-UP

5.1 DIRECTION OF ROTATION



Before starting the Rotary blades vacuum pump make sure that the P.T.O. shaft turns freely and that the direction of rotation is the same as the one indicated by the arrow.

Never turn the rotary blades vacuum pump in the direction of rotation opposite to the one for which it has been prepared (indicated by the arrow) as this could damage some components as well as prevent the operation of the pump.

6 - SET-UP OF THE LUBRIFICATION SYSTEM

Three different types of lubrication have been developed for the rotary blades vacuum pump (see Figure 3).

6.1 FORCED LUBRICATION

Lubrication occurs in both the intake phase and the compression phase through a gear pump placed at the back and actuated by the rotor shaft. The gear pump sucks oil from the tank and sends it to the manually adjusted metering tap. Excess oil returns to the tank through a tube connecting the tap to the tank. Forced lubrication is available as standard on the BALLAST 3500-4500-6000-7500-9000-11000-13500 models.

6.2 AUTOMATIC LUBRICATION

With this system lubrication occurs in both the intake phase and the compression phase by means of a piston metering pump with adjustable flow rate placed at the back and actuated by the rotor. The oil is injected directly into the Rotary blades vacuum pump, eliminating manual adjustment and saving a considerable amount of oil. Automatic lubrication is provided, on request, on the BALLAST 3500-4500-6000-7500-9000-11000-13500 models and as standard on the BALLAST 16000 model.

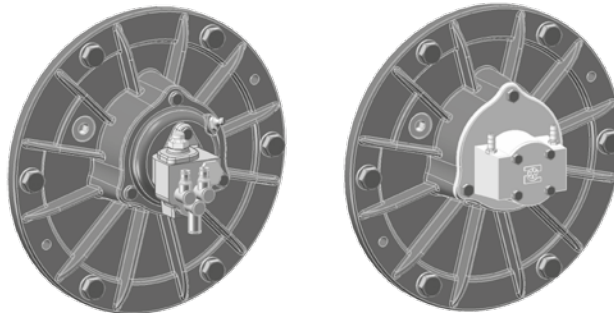

Figure 3

Automatic lubrication

Forced lubrication

6.3 RECOMMENDED OIL

The rotary blades vacuum pumps are supplied without lubrication oil in the tank. Battioni Pagani® **RECOMMENDS** use of the BATTIONI PAGANI “VACUUM PUMP OIL” for internal lubrication which ensures

- Excellent resistance to oxidation
- Strong anti-rust property
- Excellent anti foam power
- Working temperature from -5 °C to 160 °C

WITHOUT VACUUM PUMP OIL USE ONLY
NEW MINERAL OIL ISO VG 100 (SAE 30)





6.3.1 UNDER NO CIRCUMSTANCES USE THE FOLLOWING TYPES OF OIL



Transmission oil - used oil - hydraulic oil - vegetable oil -
GEAR OIL - BRAKE OIL.

6.3.2 GEARBOX OIL

All M-MA-K-KA versions (with gearbox) are equipped with oil into the gearbox. If you have to change the oil use only ISO VG 460

6.3.3 COMPARISON TABLE OF THE MAJOR BRANDS OF MINERAL OIL

	ESSO	IP	API	AGIP	CASTROL	SHELL	MOBIL
ISO VG 100	NUTO 100	HERMEA 100	COMPRESSOR OIL 100	ACER 100	AIRCOL PD 100	VITREA M 100	DTE 10 EXCEL 100
ISO VG 460	SPARTAN EP 460	HERMEA 460	DT 460	ACER 460	ALPHA SP 460	VITREA M 460	DTE FM 460

6.4 OIL LEVEL

BALLAST SERIES 3500-4500-6000-7500-9000-11000-13500

BALLAST SERIES 16000



BALLAST SERIES 3500-4500-6000-7500-9000-11000-13500

For internal lubrication, the minimum oil level is indicated by the notch at the lower end of the level rod (see Figure 4) located on the manifold and consequently the maximum level will be reached when the tank is full.

SERIES BALLAST 16000

For internal lubrication, the minimum oil level is indicated by the lower notch on the indicator placed at the side of the external tank (see Figure 5) and the maximum level will be reached with a full tank

OIL TANK CAPACITY [l]							
BALLAST 3500	BALLAST 4500	BALLAST 6000	BALLAST 7500	BALLAST 9000	BALLAST 11000	BALLAST 13500	BALLAST 16000
1,8	2,5	3,5	4,5	2,5	3	3,5	6,5

Table 2

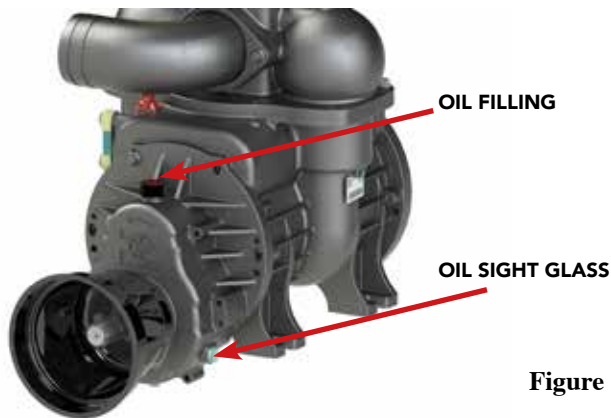

Figure 7

VERSION M – MA – K – KA: the gearbox has an oil loading plug at the top of the multiplier and an oil level plug (see Figure 7) located on the side of the gearbox that allows the level to be checked

To ensure correct lubrication, the oil should always be visible in the oil level.

6.5 LUBRICATION OIL QUANTITY

During operation of the rotary blades vacuum pump check that the amount of oil indicated by Table 3 is dripping from the relevant regulator tap. Those quantities are valid both for the Automatic and for the Forced Lubrication.

When necessary, add only unused clean oil to the tank.

In case of intense use that causes overheating of the pump, increase the above values by approximately 50%.

VERSION /M – MA – K - KA: in the gearbox perform the initial oil change after approximately 100 hours of actual work and perform subsequent changes after approximately every 300 hours of actual work.

MODEL	Totaldrops/min under vacuum max	Totaldrops/min air flow free air	r/h at max vacuum	r/h air flow free air
BALLAST 3500	25 - 30	12 - 15	63	32
BALLAST 4500	25 - 30	12 - 15	63	32
BALLAST 6000	30 - 40	15 - 20	80	40
BALLAST 7500	40 - 50	20 - 25	100	50
BALLAST 9000	50 - 60	25 - 30	120	60
BALLAST 11000	50 - 60	25 - 30	120	60
BALLAST 13500	50 - 60	25 - 30	120	60

MODEL	Drops/min for each drain cock at max vacuum	Drops/min for each drain air flow free air	g/h for each drain cock at max vacuum	r/h for each drain cock air flow free air
BALLAST 16000	20 - 25	12 - 15	50	25

Table 3



BALLAST 16000 P - D -H 4 Drain cocks
BALLAST 16000 M / MA / K / KA / G / GA 3 Drain cocks



6.6 LUBRICATION OIL ADJUSTMENT

To adjust the dripping of oil in the Rotary blades vacuum pump with forced lubrication, turn the regulator ring nut “A” (see Figure 8) after loosening ring nut “B”.

Tighten ring nut “B” again when adjustment has been completed.

The adjustment of oil delivery, in automatic lubrication, is carried out at our factory during final testing of the Rotary blades vacuum pump.

If for a particular reason a different setting is required, proceed as follows: remove the pin cover (see Figure 9), loosen the nut "C" and then act on the "A" adjustment pin.

By rotating clockwise lower oil delivery is obtained (-), and by rotating anticlockwise higher oil delivery is obtained (+). When adjustment has been completed tighten lock nut “C” and screw cover.

ENGLISH

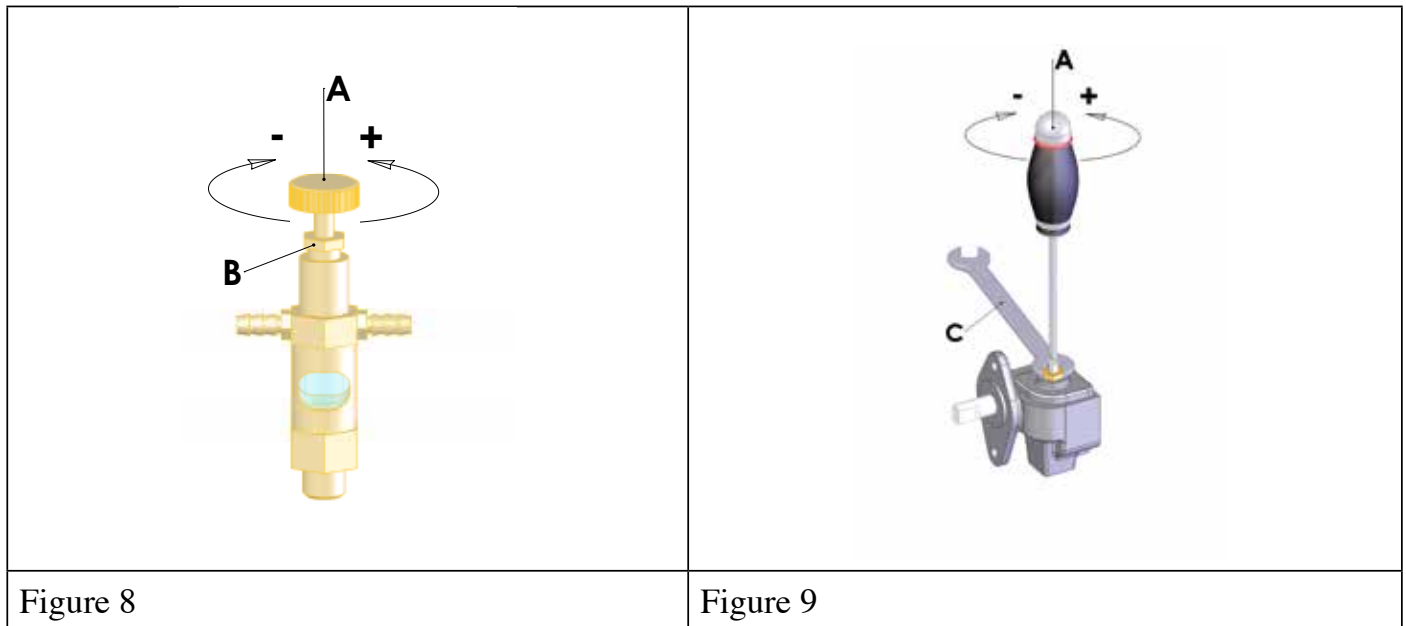

7 – OVERPRESSURE AND VACUUM ADJUSTMENT VALVES

The following diagram describes the standard valves (O), those available upon request (X) and those not available (-) for each model of rotary blades vacuum pump.

	VACUUM ADJUSTMENT VALVE 1" 1/2	OVERPRESSURE VALVE 1" 1/2	OVERPRESSURE VALVE 2"
BALLAST 3500-4500-6000-7500	-	X	-
BALLAST 9000-11000-13500	X	-	X
BALLAST 16000	X	-	-

O = Standard X = Upon request - = Not available

Table 4

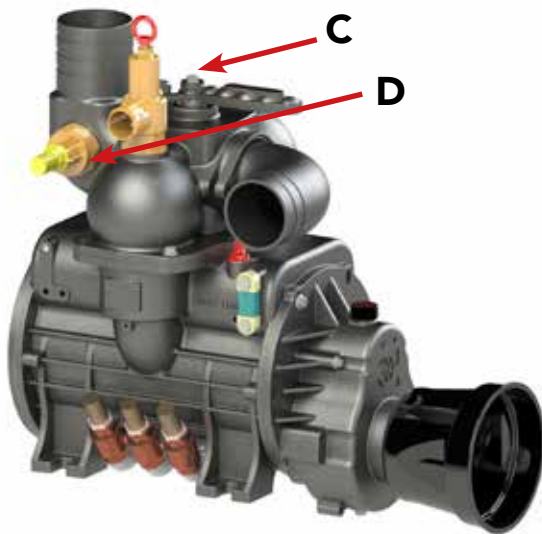

Figure 10



ATTENTION: The system must ALWAYS be equipped with a vacuum regulating valve (calibrated at -0.80 bar) and overpressure valve (calibrated at 1 bar).

Pressure: the maximum permitted pressure is 2,5 absolute bar (1.5 relative bar). In order to avoid exceeding this value or to obtain a lower max pressure, an overpressure valve, “C”, must be applied that is of a size capable of discharging the excess air delivery. Working pressure 2 bar absolute (1 bar relative).

Vacuum: too high a vacuum can cause ovality and undulation of the body or breaking of the blades. It is therefore advisable to use a vacuum regulator valve, “D”. These valves may be fitted on the manifold cover or on manifold of the Rotary blades vacuum pump. Vacuum working degree is of -0,80 bar.



*Adjustment of the valves must be performed by the customer at the testing phase.
The regulation of the valves is done by acting on the throttle placed on the valve same (overpressure valve) or action on nut and locknut (vacuum adjustment valve).*

8 - TESTING AND RUNNING IN

8.1 TESTING

All the Battioni Pagani® rotary blades vacuum pumps are tested before delivery at our factory.



*To carry out testing of the rotary blades vacuum pump verify the previous steps, possibly using a workbench.
Ensure that the shaft of the power take-off (PTO) turns freely and that the direction of rotation is the same as that indicated by the arrow.*



*In case of verification of operation of the rotary blades vacuum pump without connection to the intake/discharge pipes, there is a danger of severing for the operators due to access to the inside of the discharge elbow. There is also danger under the same conditions of the intake of foreign objects inside the machine.
Check that the handle position is correct and that the rotary blades vacuum pump is intaking or compressing.*

8.2 RUNNING IN

The running in period foreseen for a rotary blades pump is of 30 of effective working. During that period the working parameters must be reduced of 20%



9 - START, OPERATION, STOP

9.1 STARTS

The Rotary blades vacuum pump does not have a start button. Therefore to start it just transmit the motion to the power take-off (P.T.O.). The way this is done depends on the version of Rotary blades vacuum pump. Before starting make sure that the rotary blades vacuum pump is supplied with oil for internal lubrication (and lubrication of gearbox in versions .../M-MA and .../K-KA).



Before starting the rotary blades vacuum pump, make sure that the guards on all the moving parts are in place and efficient. Any damaged or missing components must be replaced and installed correctly before using the transmission. For the M, MA, K, KA and D versions clean and grease the power take off before inserting the cardan transmission.

9.2 OPERATION



For correct operation of the pump, it is advisable before starting work to operate the pump at 700 rpm without suctioning/compressing the air inside the tank for approximately 2 minutes to ensure pre-lubrication of the pump.



For correct use of the pump, it is advisable to start loading with the stemgate of the suction tube open, avoiding creating a vacuum in the tank and then open the stemgate.



For correct operation of the pump, at the end of the loading or unloading cycle it is advisable to operate the pump at 700 rpm without suctioning/compressing the air inside the tank for approximately 2 minutes in order to lower the temperature inside the pump.



Do not use the rotary blades vacuum pump at pressures, temperatures and for a time greater than what is indicated in Table 5. During use, do not exceed the conditions of speed and power established by the manual. Do not overload the machine or suddenly engage the P.T.O.



Once the desired vacuum has been reached it is advisable to reduce the rotations of the rotary blades vacuum pump. The volume of air to be suctioned is only what corresponds to the volume of liquid loaded in the tank. This simple measure, which does not increase the loading time of the tank, translates into lower consumption of the blades. Do not use the rotary blades vacuum pump at the maximum rotation speed indicated on the identification plate for longer than two minutes.



The capacity and degree of vacuum inside the tank can be adjusted by changing the speed of rotation and by not using the vacuum control and pressure surge valves. If the rotary blades vacuum pump is stopped with vacuum in the tank greater than -0.80 bar it is completely normal that the entrance of air through the vacuum adjustment valve will take the depression in the tank to -0.80 bar.

PARAMETER		WORKING RATE (RECOMMENDED)	MAXIMUM SPEED
Speed of revolutions M, K	[rpm]	350 - 500	see plate
Speed of revolutions MA,P,D,H,KA	[rpm]	750 - 1000	see plate
Pressure	[bar]	0.5 - 1	1.5
Vacuum	[bar]	-0.80	-0.95
Cylinder outer temperature compression side [°C]	[°C]	80 - 100	130
Operating time (long life blades) vacuum -0.80 bar	[min]	6 - 8	15
Operating time Ballast at vacuum -0.70 bar	[min]	continuous	continuous

Table 5



Failure to comply with these requirements could be detrimental to the health of the user or could damage the rotary blades vacuum pump . If the density of the material to be pumped is significant, dilute or mix the same material. The period of operation should be such as not to cause the maximum temperature to be reached. A period of prolonged use without interruption can cause, in addition to overheating, damage to the blades.

9.3 STOPPING

To stop the rotary blades vacuum pump, stop the engine and disconnect the P.T.O. in order to prevent accidental operation of it.

9.4 CONTROL DEVICES

A handle, located at the top of the manifold, is provided for the control of intake and compression phases. This can be operated manually. To establish in which direction the handle must be turned to select the suction or compression phase, follow the instructions given by the manufacturer of the installation. If the reversing gear locks up, use a lever to lift the handle.



Selection of the intake or compression phase with the handle must be made with the Rotary blades vacuum pump not operating.

9.5 TEMPERATURE INDICATOR (THERMO TAPE)

The temperature indicator is secured on the compression side of all the BALLAST versions

This temperature indicator provides two temperature readouts:

- In the lower part there is a reversible scale that changes colour (from black to blue) at a specific temperature (ranging from 90°C to 120°C). This scale is designed to help the user prevent overheating of the pump.
- A blue square with a white dot at the centre (a non-reversible indicator) is located at the upper right on the scale. that turns black when the temperature rises to 160°C. If the dot turns black this means that the pump has been used for more than 15 minutes at the maximum vacuum level (incorrect use of the pump) If this occurs, the pump must be disassembled and all the seals, oil seals and blades must be replaced.



9.6 CAP VALVE BALLAST

The cap valve positioned on the suction duct maintains the vacuum created in the tank during the loading operations. The valve also allows maintains the pressure created in the tank during the unloading operations; This prevents the loss of pressure during the field end manoeuvres when the PTO is disconnected.

The valve also prevents, in case of sudden stops of the cardan shaft, the pump rotor activating in counter-rotation the hydraulic PTO of the tractor



9.7 INTEGRATEWD AIR FILTER BALLAST 16000

The cartridge air filter (stainless steel mesh) is integrated within the manifold and works both in vacuum and under pressure, preventing the penetration of foreign bodies into the pump body. Unscrewing the 4 M10 screws on the manifold provides access to the filter cartridge that must be cleaned regularly with water or diesel oil by blowing it with compressed air. Failure to clean the filter could lead to overheating of the pump and deterioration of performance.





9.8 CRASH PROTECTION SYSTEM



The BALLAST pump is equipped with a system that allows the flange to slide, which prevents breakage if foreign bodies become lodged between the rotor and the pump body. (Except for version G-GA)

To benefit from this system, it is important to follow these instructions:

Before starting the pump, make sure the rotor has not dropped down accidentally. This can be accomplished by making sure the cut machined into flange lines up with the cut machined into pump body.

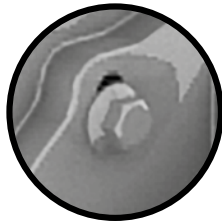

Flange slot

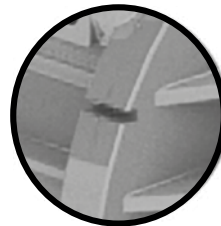

Cut for aligning flange with pump body

9.9 BALLAST COOLING AIR FILTERS

The rotary blades vacuum pumps of the BALLAST series were designed and created to allow their use in continuous service at -0.70 vacuum bar, thanks to a cooling system for air injection at ambient temperature that, after passing through a filter and with the resistance of a non-return valve, enters the side dedicated to compression, decreasing the internal temperature.

The intended use is semi-industrial, suitable for all applications that do not require the exceeding of substantial and consistent hydrostatic pressure and consequently of a very high degree of vacuum but which require a longer operation time compared to traditional use. Regularly clean the cooling air injection filters with compressed air



9.10 FLUSHING KIT BALLAST 16000

On the intake manifold there is a 1/4 gas hole (closed by a screw on the standard version) where it is possible to inject diesel fuel for cleaning of the pump. There will be an optional kit with plastic tank and tap to be positioned on the tank for this operation.

9.11 PROTECTIVE DEVICES ADOPTED



The Rotary blades vacuum pump, when being installed on a machine, must be equipped with a protective device to isolate the moving parts and prevent access to them by the operators.



It is necessary to protect the Rotary blades vacuum pump to avoid the remote danger of material projection in case of heavy breakage.

M-MA, K, KA and D versions are equipped with a CE plastic protective device. It insulates and protect of P.T.O. shaft during moving

9.12 INDIVIDUAL MEANS OF PROTECTION TO BE USED



When operating the Rotary blades vacuum pump, it is necessary to use the individual means of protection prescribed by the Manufacturer of the machine on which the Rotary blades vacuum pump has been installed.



10 - TROUBLESHOOTING

PROBLEM	CAUSE	REMEDY
Little vacuum or pressure	Blades are worn	Replace blades
	Some blades jammed in rotor	Disassemble the rotary blades vacuum pump, clean and wash the rotor, the blades and the body.
	Air infiltration or leakage from system	Eliminate infiltrations
	Undulated cylinder	Smooth or replace the body
	Reversing gear badly positioned	Remove reversing gear and position it correctly
	Flange assembly too tight	Add a gasket to the back flange
	Movement of sliding flange	Replace the pins supplied between body and flange for alignment
	Check the operation of the cap valve on the suction duct	Unblocking
Overheating	Excessive pressure	Reduce pressure
	Excessive rate of revs	Reduce rate of revs
	Excessive operating time	Reduce operating time
	Blades too long	Trim blades to correct size
	Lack of lubrication	Check oil level in tank, oil pump operation, setting of oil tap
	Suction filter cartridge clogged	Wash and blow the filter cartridge
	Ballast filter clogged	Wash and blow the filter
Beating against external surface	Rate of revs too low	Increase rate of revs
	Excessive/short and/or not suitable lubrication oil	Clean the rotary blades pump and replace the oil
Leakage of sewage from the discharge elbow	Malfunctioning of valves	Check valves
Smoke comes out of discharge elbow	Excessive lubrication	Adjust lubrication
Insufficient lubricating oil circulation (for versions with automatic lubrication)	Suction of air from the fittings	Replace the fittings
	Lubrication tube badly inserted in pipe fittings	Insert lubrication tube correctly
	Air in oil pump chamber	Fill pump chamber with oil
P.T.O. does not rotate	Broken blades	Replace blades (check if rotor pin is bent)
	Foreign body in rotary blades vacuum pump	Remove foreign body
No suction / no compression	Handle incorrectly positioned	Position handle correctly
	Reversing gear incorrectly positioned	Position reversing gear correctly
	Rotary blades vacuum pump rotates in wrong direction	Reverse direction of rotation
	All blades jammed	Disassemble rotary blades vacuum pump, clean and wash blades, rotor and body
	Blades protrude from the rotor slots anomalously	Disassemble rotary blades vacuum pump, clean and wash blades, rotor and body
	Rubber ball closes overflow valve	Increase passage of air inside valve
Locking of handle	Foreign liquid in filling pump	Remove and clean with diesel oil
	Non-use	Lift handle with a lever



11 - MAINTENANCE, INSPECTIONS AND CHECKS, REPAIRS, TECHNICAL ASSISTANCE



When carrying out maintenance operations, inspections, checks or repairs it is advisable to wear the individual protective devices listed in this manual.



If the tank has not been used for a long time, ensure the PTO shaft turns freely and rinse the pump with 200 ml of diesel fuel. After this it is important to operate the pump with regulator valve completely open for 20 sec. (forced lubrication version) or introduce into the pump approximately 100 ml of oil from the discharge bend (automatic lubrication version) with the compression pump. This will ensure good lubrication of the blades before working with the liquids. The final step is to adjust the valve for correct operation.



All maintenance operations, inspections, checks and repairs must be carried out with the greatest care and with the Rotary blades vacuum pump off and the P.T.O. disconnected.

11.1. CLEANING

11.1.1 WASHING OF THE BODY

If sewage enters the Rotary blades vacuum pump, the inside of the body must be washed immediately, by making it suck in diesel or fuel oil through the discharge elbow with the Rotary blades vacuum pump in compression phase. After this operation make it suck in oil. The same operation should be carried out when the Rotary blades vacuum pump has to remain inactive for a long time. In this case, disconnect the suction and delivery tube connected to the valves and hermetically seal the manifold cover because the gasses that form inside the tank would pass into the Rotary blades vacuum pump and cause the inside of the body to rust and this in turn could cause the blades to break when the system is re-started.

In order to avoid rust formation, do not use water.

If the body is washed after it is disassembled, it is advisable to carry out a preliminary wash with detergents (e.g. thinners) before carrying out the above operation.

11.1.2 WASHING OF OIL TANK

Wash the oil tank at least once a year. Remove the manifold, and then wash it using solvents.

11.1.3 WASHING AND CLEANING OF VALVES

Wash and clean the valves at least once a month. Remove the valves, then wash them with water or, if necessary, non-corrosive detergents.

11.2 CHECKING OF VALVES

Regularly check that all the valves, for both overflow and pressure/vacuum, are still working efficiently.

11.3 INSPECTION AND REPLACEMENT OF THE BLADES

11.3.1 "LONG LIFE" BLADES GENERAL INFORMATION

The LONG LIFE blades are made from a special material suitable for industrial uses for rotary blades vacuum pumps used in the agricultural field. These blades offer excellent resistance against wear and thermal and mechanical stress. It is suitable for the most common uses and for the suction of denser sewage. It is recommended for systems used by contractors and also for frequent and repeated uses during the same day.

Apart from normal wear, it may be necessary to replace the blades following incorrect use of the Rotary blades vacuum pump. The most frequent causes come from heat, lack of lubrication, entrance of sewage, high pressure or vacuum, formation of rust inside the body due to prolonged inactivity.

With the heat too high pallets stretch to touch the plate front and rear, this causes the breakdown of the pallets.

Lack of lubrication means the blades are completely dry like the inside of the pump. This increases their fragility and causes them to break lengthways.

The same type of breakage can be caused by entrance of sewage or by a too high working pressure.

A too high vacuum causes the blades to beat against the cylinder with consequent damage to the outside of the blades. Moreover, the lining becomes wavy.



Figure 11

11.3.2 INSPECTION OF BLADES

To check the state of wear of the blades in the rotary blades vacuum pump proceed as follows:

- Remove the threaded inspection plug (fig. 11);
- Rotate the rotor until a blades lines up with the inspection hole;
- Compare the height of the blade with the reference ring on the rotor;
- Replace the entire set of blades when the height is less than the reference ring on the rotor.

11.3.3 REPLACEMENT OF BLADES

1. Check whether there is sufficient space at the back of the rotary blades vacuum pump to operate smoothly, otherwise the rotary blades vacuum pump must be previously dismantled from its support;
2. Remove the back
3. Extract the blades from the rotor;
4. Clean the Rotary blades vacuum pump.
5. Replace the blades and the gasket and the seals of the rear flange;
6. Re-fit the back of the rotary blades vacuum pump
7. Use only Battioni Pagani® original spare parts



Request the rotary blades vacuum pump servicing kit containing a single blister: Battioni Pagani® original blades, gaskets and oil seals

11.3.4 BLADE SIZES

MODEL	BLADE NUMBER	BLADE MEASUREMENT
BALLAST 3500	8	205x43x6,5
BALLAST 4500	8	260x43x6,5
BALLAST 6000	8	350x43x6,5
BALLAST 7500	8	430x43x6,5
BALLAST 9000	8	300x60x6,5
BALLAST 11000	8	370x60x6,5
BALLAST 13500	8	460x60x6,5
BALLAST 16000	6	410x82,5x7,5

Table 9



IMPORTANT: Ensure the blades received as replacements are of a length that is less than or equal to the nominal size indicated by Table 9. Use only Battioni Pagani® original spare parts.



11.4 REPLACEMENT OF THE GEARS (VERSION M –MA and K-KA)

1. Unscrew the screws of the gearbox cover;
2. Use two screws for screwing into the threaded extraction holes until the cover is removed;
3. Take out the gear with splined shaft using an extractor if necessary;
4. For the pinion: unscrew the self-locking nut, use an extractor or a press.

11.5 TECHNICAL ASSISTANCE

For technical assistance and the supply of spare parts and accessories contact Battioni Pagani® authorised distributors.

11.6 PERIODIC MAINTENANCE

SERVICING TO BE CARRIED OUT	HOW TO PROCEED	FREQUENCY
Check oil circulation	Inspect the level sight glasses	Once a day
Check oil level in tank	Use the oil level on outside of tank	Once a week
Check wear of blades	Remove threaded plug	Every 300 working hours:
Check that the over-pressure and vacuum regulator valves are working correctly	Remove valves	Once a month
Wash oil tank	Remove tank	Once a year
Wash body internally	Put in oil + diesel oil (after washing lubricate with oil only)	Whenever sewage enters or when inactive for a long time
Wash lubrication pump	Use a brush and compressed air	Once a year or for prolonged inactivity
Check that the overflow valves are working correctly	Remove valves	Once a month
Wash and suck the filter cartridge	Remove the filter cartridge	Once a week
Wash the Ballast valve filter	Disassemble the filter	Once a month
Lubricate the power take-off (versions (M - MA - K - KA and D)	Oil the P.T.O. with a brush and lubricating oil	Once a month
Wash and clean the valves	Remove valves	Once a month

12 - PUTTING OUT OF SERVICE AND DEMOLITION

Before demolishing the Rotary blades vacuum pump the following materials should be separated:

- lubricating oil;
 - rubber and plastic parts;
 - cast iron and steel parts;
- and disposed of correctly.

Do not discard the Rotary blades vacuum pump in the environment.

For disposal of the lubricating oil make use of specialised treatment services.

DATI TECNICI (Technical data/Données techniques/ Technische daten/Datos técnicos)		BALLAST	BALLAST	BALLAST	BALLAST	BALLAST	BALLAST	BALLAST	BALLAST	BALLAST	BALLAST
		3500	4500	6000	7500	9000	11000	13500	16000		
Portata max (Max rate of flow/Debit maximum/Max forderleistung / caudal max)	(l/min)	3621	4593	6183	7596	9.030	11.135	13.845	15.210		
Regime di lavoro max BALLAST M/K (Max rpm/Tours maximum/Max drehzahl / rpm max)	(rpm)	540	540	540	540	600	600	600	540		
Regime di lavoro max BALLAST/P/D/H/G (Max rpm/Tours maximum/Max drehzahl / rpm max)	(rpm)	1400	1400	1400	1400	1400	1400	1400	1400		
Regime di lavoro max BALLAST/MA/KA (Max rpm/Tours maximum/Max drehzahl / rpm max)	(rpm)	-	-	-	-	1000	1000	1000	1000		
Pressione max assoluta (relative) (Max working pressure/Pression max d'utilisation/Max betriebsdruck / presión max absoluta)	(bar)	2.5 (1.5)	2.5 (1.5)	2.5 (1.5)	2.5 (1.5)	2.5 (1.5)	2.5 (1.5)	2.5 (1.5)	2.5 (1.5)		
Vuoto max (Max vacuum/Vide maximum/Max vacuum / Vacio max)	(bar)	-0.92	-0.92	-0.94	-0.94	-0.95	-0.95	-0.95	-0.95		
Ass. Potenza a pressione max BALLAST/M (Power absorption max pressure/Absorption puissance pour pression max/Leistungsbedarf bei max Druck / Maximo poder de absorción de presión)	(kW)	16	20	22	25	36	40	44	48		
Ass. Potenza a vuoto max BALLAST (Power absorption per max vacuum/Absorption puissance pour vide maximum/Leistungsbedarf bei max Vakuum / Vacio de poder de absorción max)	(kW)	8	10	12	14	17	21	25	33		
Peso netto BALLAST/M/MA (net weight / poids net / netto-Gewicht / Peso neto)	Kg	101	111	126	144	145	160	168	230		

DATI TECNICI (Technical data/Données techniques/ Technische daten/Datos técnicos)		BALLAST 3500	BALLAST 4500	BALLAST 6000	BALLAST 7500	BALLAST 9000	BALLAST 11000	BALLAST 13500	BALLAST 16000
Peso netto BALLAST/P (net weight / poids net / netto-Gewicht / Peso neto)	Kg	86	96	111	129	131	146	164	213
Peso netto BALLAST/D (net weight / poids net / netto-Gewicht / Peso neto)	Kg	87	97	112	130	132	147	165	210
Peso netto BALLAST/H (net weight / poids net / netto-Gewicht / Peso neto)	Kg	100	110	126	145	140	155	173	215
Peso netto BALLAST/HM (net weight / poids net / netto-Gewicht / Peso neto)	Kg	110	120	136	155	-	-	-	-
Peso netto BALLAST/G (net weight / poids net / netto-Gewicht / Peso neto)	Kg	87	97	113	131	139	154	172	215
Peso netto BALLAST/K/KA (net weight / poids net / netto-Gewicht / Peso neto)	Kg	-	-	-	-	-	-	-	220



2	10.05.2017	REVISIONE	PROG	R DT	AM
1	15.06.2016	REVISIONE	PROG	R DT	AM
0	12.05.2015	I° EMISSIONE	R CQ	R DT	PRES
<i>Rev.</i>	<i>Data</i>	<i>Motivo</i>	<i>Preparato</i>	<i>Approvato</i>	<i>Autorizzato</i>

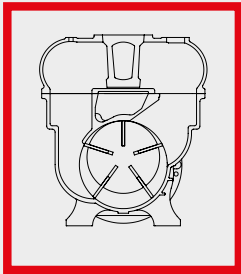

Rotary vanes
vacuum pump

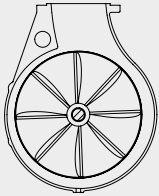

Centrifugal pump

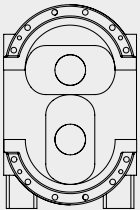

Rotary positive displacement
lobes pump

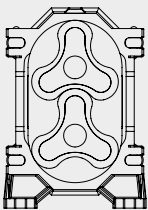

Rotary positive displacement
lobes pump

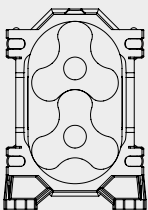

Rotary lobes
vacuum pump



**Battioni®
Pagani**

Setting the pace since 1953

Via Cav. Enzo Ferrari, 2
43058 Ramoscello di Sorbolo (PR) - Italy

Ph. +39 0521 663203
Fax +39 0521 663206



www.bapag.it
info@bapag.it





INTRODUCTION

The Rotary blades vacuum pumps Battioni Pagani Pompe® have been designed and constructed in compliance with EEC safety regulations and have been assessed for risks according to standard UNI EN ISO 12100:2010; in particular they are in conformity with directive 2006/42/CE and subsequent modifications and additions.

Since the design of this pump complies with the definition of a machine as contained in the Machinery Directive 2006/42/EC, the pump bears the CE mark on its identification plate. However, it must be pointed out that because of its application and the purpose for which it is supplied, which specifies that it be installed by the buyer (without motive power), Battioni Pagani Pompe® refuses any and all responsibility if the instructions in this operation and maintenance manual are not followed.

This manual contains the Declaration of CE conformity and all the instructions required by users, and by the manufacturers of plant systems, for using our products safely. As a result, the manual must always be kept near the rotary blades vacuum pump.



This danger symbol in the manual means that important safety instructions are given. This information is destined primarily for the operator whose responsibility it is not only to comply with them personally, but also to ensure compliance by other persons exposed to the connected risks.

The descriptions and illustrations in this manual are purely indicative.

The manufacturer reserves the right to make any type of change to this manual at any time.

GUARANTEE

At the moment of receiving the Rotary blades vacuum pump check that it is complete with all its parts.

Any anomalies or missing parts must be notified within 8 days of receipt of the product.

The Supplier guarantees that the product sold is free from defects and undertakes to repair or, by final decision, to replace the faulty parts only if the defects are clearly attributed to the manufacturing process or to the materials used. In any case the costs of labour, travel and transport, and any customs expenses shall be paid by the Purchaser. The vendor is not obliged to pay damages except in the case of fraud or grave offence. All parts subject to normal wear are excluded from the guarantee. The guarantee will cease to be valid if:

- the faults reported are the result of accidents or obvious carelessness or negligence on the part of the Purchaser,
- the parts have been modified, repaired or fitted by persons not authorised by the vendor,
- the failures and breakages have been caused by use that is unsuitable or heavier than that provided for by the vendor,
- the Purchaser has failed to make the payments as agreed by contract.

The Purchaser loses his/her right to the guarantee if he/she fails to report the defects to the vendor within 8 days of discovery, making an exception to article 1512 of the Italian Civil Code. The Vendor reserves the right to make changes or improvements to his/her products without being obliged to make the same changes or improvements to the units already produced and/or delivered previously. The Vendor is not responsible for accidents or for the effects of accidents to people or property due to defective materials and/or workmanship.

Thank you for choosing Battioni Pagani Pompe®.

Battioni Pagani Pompe®



OBLIGATORY SAFETY SIGNS TO BE DISPLAYED IN THE WORK PLACE AND IN THE VICINITY OF THE ROTARY BLADES VACUUM PUMP



INDIVIDUAL
MEANS OF
PROTECTION
THAT IT IS
OBLIGATORY
TO USE

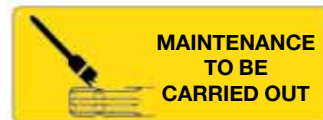

DIRECTION OF ROTATION OF THE
HANDLE TO SELECT SUCTION OR
COMPRESSION PHASES

CONDITIONS AND LIMITS OF USE – LIST OF DANGERS

In the Common Market countries, the installation must comply with directive 2006/42/CE and subsequent modifications, while in the other countries it must comply with the safety regulations of the country.

This Rotary blades vacuum pump has been designed to create a vacuum or pressure inside a tank connected to it.



Under no circumstances must liquids, dust or any kind of solid matter enter the Rotary blades vacuum pump because they could cause it to break. Therefore it is necessary to equip the system with safety valves.

The use of the Rotary blades vacuum pump for any purpose other than that specified above is absolutely forbidden, not provided for by the manufacturer and therefore highly dangerous.

Do not use the Rotary blades vacuum pump to handle flammable and/or explosive liquids and materials or for materials that give off flammable gasses.

Read This Manual Before Using The Suction Unit/Compressor

Do not use the rotary blades vacuum pump in a potentially explosive atmosphere.

Never remove the guards fitted on the Rotary blades vacuum pump and always check their efficiency every time the machine is used.

Any work on the machine must be carried out while it is not running.

Failure to comply with the instructions given in this manual may lead to the following dangers:

- Danger of being crushed by the Rotary blades vacuum pump mass during handling and transport;
- Danger of getting entangled in the shaft transmission parts if the necessary guards are removed;
- Heat dangers due to the temperatures that can be reached by the Rotary blades vacuum pump;
- Acoustic danger due to the noise generated and to failure to use personal means of protection;
- Danger to operator's hands during testing with suction and delivery tubes detached from the pump;
- Danger of abrasion from the shaft of the hydraulic pump support if the Rotary blades vacuum pump is operated with the hydraulic pump removed;
- Danger of projection of fluid and solid materials owing to an heavy breakage of the Rotary blades vacuum pump.



SUMMARY

INTRODUCTION.....	30
GUARANTEE.....	30
OBLIGATORY SAFETY SIGNS TO BE DISPLAYED IN THE WORK PLACE AND IN THE VICINITY OF THE	
ROTARY BLADES VACUUM PUMP.....	31
CONDITIONS AND LIMITS OF USE – LIST OF DANGERS.....	31
SUMMARY	32
GENERAL INFORMATION	34
1 - VERSIONS OF THE ROTARY BLADES VACUUM PUMP	34
1.1 IDENTIFICATION LABEL	35
INSTRUCTIONS FOR USE AND MAINTENANCE.....	36
2 - PACKAGING, STORAGE, HANDLING AND TRANSPORT.....	36
2.1 PACKAGING	36
2.2 STORAGE.....	36
2.3 HANDLING AND TRANSPORT.....	36
3 - ASSEMBLY, FITTING, INSTALLATION, DISASSEMBLY, RE-FITTING.....	36
3.1 INSTALLATION DRAFT.....	36
3.2 DOUBLE OUTLET INSTALLATION DRAFT.....	37
3.2.1 DIAGRAM OF INSTALLATION WITHOUT MANIFOLD ON IRRIGATION MACHINES	9
3.3 ASSEMBLY AND FITTING - INSTALLATION	37
3.4 HYDRAULIC PLAN (/H VERSION).....	38
3.5 INSTRUCTIONS FOR USE AND MAINTENANCE OF HYDRAULIC MOTOR	39
3.6 DISINSTALLATON.....	41
3.7 DISASSEMBLY	41
3.7.1 Back disassembly.....	41
3.7.2 Front disassembly.....	42
3.8 RE-FITTING – RE-INSTALLATION.....	42
3.8.1 Re-fitting of the back	42
3.8.2 Re-fitting of the manifold	43
3.8.3 Re-fitting of the front.....	44
3.8.4 Correct positioning of reversing gear	44
4 - DIRECTION OF ROTATION INVERSION	45
5 - START-UP	45
5.1 OPERATION WITHOUT OVER-PRESSURE VALVE (ONLY MEC SERIES).....	45
5.2 DIRECTION OF ROTATION.....	45

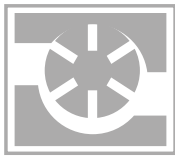

6 -	SET-UP OF THE LUBRICATION SYSTEM	46
6.1	NORMAL LUBRICATION.....	46
6.2	FORCED LUBRICATION.....	46
6.3	AUTOMATIC LUBRICATION	46
6.4	OIL TO USE.....	46
	6.4.1 Absolutely, do not use following oil brands	46
	6.4.2 Gearbox oil	47
6.5	OIL LEVEL.....	47
6.6	QUANTITY OF LUBRICATION OIL.....	48
6.7	REGULATION FOR LUBRICATING OIL	49
7 -	OVERPRESSURE AND VACUUM ADJUSTMENT VALVES.....	49
8 -	TESTING AND RUNNING IN	50
8.1	TESTING.....	50
8.2	RUNNING IN	50
9 -	START, OPERATION, STOP	51
9.1	START	51
9.2	OPERATION	51
9.3	STOP	52
9.4	CONTROLS	52
9.5	PROTECTIVE DEVICES.....	52
9.6	PROTECTIVE DEVICES.....	52
9.7	INDIVIDUAL MEANS OF PROTECTION TO BE USED	52
10 -	TROUBLESHOOTING	53
11 -	MAINTENANCE, INSPECTIONS AND CHECKS, REPAIRS, TECHNICAL ASSISTANCE.....	54
11.1	CLEANING	54
	11.1.1 Washing of the body.....	54
	11.1.2 Washing of oil tank	54
	11.1.3 Washing and cleaning of valves	54
11.2	CHECKING OF VALVES.....	54
11.3	INSPECTION AND REPLACEMENT OF Blades	54
	11.3.1 General information on blades	54
	11.3.2 Inspection of blades.....	55
	11.3.3 Replacement of blades	55
	11.3.4 Blades dimensions.....	56
11.4	REPLACEMENT OF RUBBER BALL.....	56
11.5	REPLACEMENT OF GEARS (VERSION / M - MA / K - KA).....	56
11.6	TECHNICAL ASSISTANCE	57
11.7	REGULAR SERVICING.....	57
12 -	PUTTING OUT OF SERVICE AND DEMOLITION	57
SPARE PARTS	254	
TECHNICAL DATA	305	



GENERAL INFORMATION

1 - VERSIONS OF THE ROTARY BLADES VACUUM PUMP

The Rotary blades vacuum pump can be supplied in the following versions:

SERIE	M	MA	P	D	H	K	KA	G	GA
MEC 1000/1600	O	-	O	-	-	-	-	-	-
MEC 2/3/4000	O	-	O	O	O	-	-	O	O
MEC 5/6.5/8000	O	-	O	O	O	-	-	O	O
MEC 9/11/13500	O	O	O	O	O	-	-	O	O
STAR 60-72-84	O	O	O	O	O	O	O	O	O
AGRI 60-72-84	O	O	O	O	O	O	O	O	O

- Not available O Available

.../ M VERSION--.../MA VERSION (with gearbox)

ANTICLOCK
WISE



- ... / **M** the power take-off is actuated through a cardan shaft at 540 r.p.m. This version can be recognised by the gearbox placed at the front of the Rotary blades vacuum pump and by the identification plate.
- ... / **MA** the power take-off is actuated through a cardan shaft at 1000 r.p.m. This version can be recognised by the gearbox placed at the front of the Rotary blades vacuum pump, by the identification plate and by the punching placed on the upper part of the gearbox.

.../ P VERSION (for pulley application)

CLOCK
WISE



ANTICLOCK
WISE
ON REQUEST

- ... / **P** the power take-off is actuated through a pulley and belts. This version can be recognised by the cylindrical shaft with key of the power take off and by the plate, .../P pulley application.

.../ D VERSION (direct drive)

ANTICLOCK
WISE



CLOCK WISE
ON REQUEST

- ... / **D** the power take-off is actuated through a cardan shaft directly connected to the splined hub. This version can be recognised by the splined hub placed at the front of the Rotary blades vacuum pump and by the identification plate, .../D direct drive

.../H VERSION (for hydraulic drive)

CLOCK
WISE



- ... / **H** the power take-off is actuated through a gears hydraulic motor. This version can be recognised by the hydraulic motor support placed at the front and by the identification plate, .../H hydraulic drive.



.../ K VERSION –.../KA VERSION (with gearbox and hydraulic pump support)

ANTICLOCK
WISE



- ... / K the power take-off is actuated through a cardan shaft at 540 rpm and is designed to actuate an hydraulic pump of group 2 or group 3. This version can be recognised by the hydraulic pump support and by the identification plate.
- ... / KA the power take-off is actuated through a cardan shaft at 1000 rpm and is designed to actuate an hydraulic pump of group 2 or group 3. This version can be recognised by the hydraulic pump support, by the identification plate and by the punching placed on the upper part of the gearbox.

Versions... /K and ... /KA have been designed so that they can be used to actuate the hydraulic accessories (gate valves, draft tube, support base etc.) on the tank car because in many cases the hydraulic pump on the tractor does not have sufficient oil flow rate for all the movements. With this application all the work may be carried out from the tractor cabin by operating only one distributor

.../ G VERSION –.../GA VERSION (application for GARDA or LEDRA)

CLOCK
WISE



- ... / G version of Rotary blades vacuum pump that is applied on the GARDA or the LEDRA group; it cannot be used on its own. This version can be recognised by the external pinion placed at the front of the Rotary blades vacuum pump and by the identification plate.
- ... / GA version of Rotary blades vacuum pump that is applied on the GARDA or the LEDRA group at 1000 rpm; it cannot be used on its own. This version can be recognised by the external pinion placed at the front of the Rotary blades vacuum pump and by the identification plate.

All the versions of the STAR and AGRI series of Rotary blades vacuum pump can be supplied with back tank in cast iron (versions /MV, /MAV, /PV, /DV, /HV, /KV /KAV) or with extractable side tank in sheet metal (versions /MF, /MAF, /PF, /DF, /HF, /KF, /KAF).

1.1 IDENTIFICATION LABEL

Every rotary blades pump is supplied with an identification label stating:

- rotary blades pump model
- serial number
- production year
- max relative pressure
- max vacuum
- max absorbed power
- max r.p.m.
- max rate of flow
- CE mark
- weight of pump



*Every identification plate is protected by a special sky-blue colour film, to remove after painting.
This film has been introduced to guarantee the tracing of the pump for warranty purposes.*

IDENTIFICATION LABEL WITH PROTECTIVE FILM FOR PAINTING





INSTRUCTIONS FOR USE AND MAINTENANCE

2.0 - PACKAGING, STORAGE, HANDLING AND TRANSPORT

2.1 PACKAGING

The Rotary blades vacuum pump are supplied without packaging. On request the following packaging can be used:

- wooden base and shrink-wrap;
- wooden cases and shrink-wrap for shipment by sea or air.

2.2 STORAGE

In order to preserve the Rotary blades vacuum pump correctly, it must be stored:

- under cover, sheltered from adverse weather conditions;
- resting horizontally on its four feet.

The Rotary blades vacuum pump are lubricated during testing at our factory with special oil that ensures lubrication of the various internal components for approx. 6 months.

In the event of subsequent storage it is advisable to wash the inside of the body with oil and diesel oil (as stated on this manual).

2.3 HANDLING AND TRANSPORT

Mass of Rotary blades vacuum pump: (see technical sheet).



The Rotary blades vacuum pump should be:

- *Harnessed by means of metal hooks inserted in the hole for gripping, or a sling;*
- *Lifted with a hoisting truck (if on pallet), bridge crane, or crane.*
- *MEC 1000/1600 pumps must be lifted through a 1/4" gas eyebolt that has to be fitted instead of drain cock.*

The Rotary blades vacuum pump is supplied with a guard that is in compliance with EC directives. This guard should be fitted on by the fitter using the four screws supplied.

3.0 - ASSEMBLY, FITTING, INSTALLATION, DISASSEMBLY, RE-FITTING

The procedures concerning Rotary blades vacuum pump versions .../G and .../GA are given in the GARDA/LEDRA group instructions.



When carrying out maintenance operations, inspections, checks and repairs you are advised to wear the individual means of protection listed in this manual.



All maintenance operations, inspections, checks and repairs should be carried out with the greatest care and with the tractor not running and the power take-off disconnected.



It is essential to prevent sewage from entering the Rotary blades vacuum pumps. The entrance of sewage would cause the blades and consequently the rotor to break.

It is therefore necessary to equip the system with an overflow valve, "3", and a safety overflow valve, "2", between the Rotary blades vacuum pump and the tank car (see Figure 1)

3.1 INSTALLATION DRAFT



- 1 - Pump
- 2 - Secondary shut-off valve
- 3 - Primary shut-off valve
- 4 - Silencer
- 5 - Motorized joint
- 6 - Swivel joint
- 7 - Stemgate
- 8 - Overpressure valve
- 9 - Depression valve

Figure 1



3.2 DOUBLE OUTLET INSTALLATION DRAFT

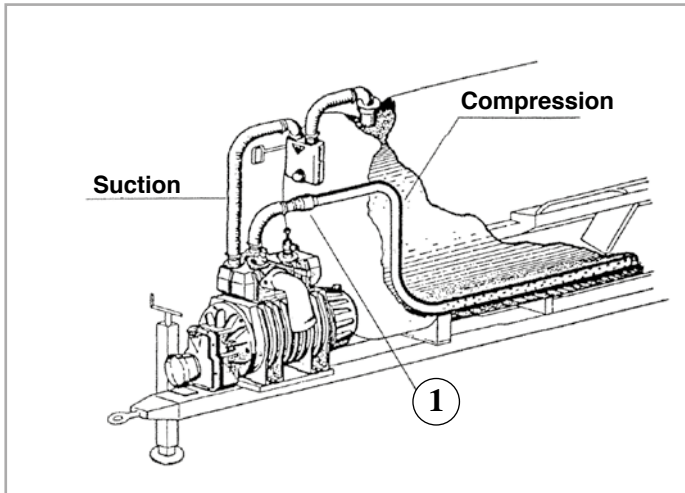

The Rotary blades vacuum pump can be used as a mixer by fitting, on request, a double outlet on the manifold (see Figure 2). In this case there will be the intake of a normal Rotary blades vacuum pump, but a perforated tube placed inside the tank car must be used for the compression. When the handle is positioned on the compression phase, the air will be forced out through the holes in the tube so causing mixing of the previously loaded sewage (never exceed the maximum working absolute pressure of 2,5 bar) equal to 1,5 relative bar.

Figure 2



With this system, a check valve (1) must be fitted on the delivery tube to prevent the transfer of sewage inside the Rotary blades vacuum pump.

3.2.1 DIAGRAM OF INSTALLATION WITHOUT MANIFOLD ON IRRIGATION MACHINES

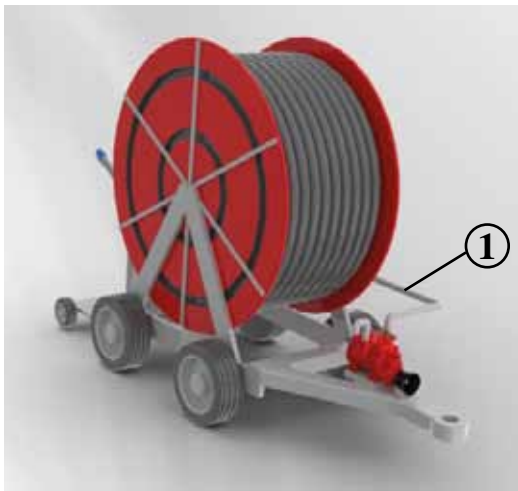

Battioni Pagani Pompe® produces a complete line of rotary blades vacuum pumps for use on irrigation machines. To use the rotary pump correctly, the irrigation machine must be completely filled with water and must not be partially empty.

Important: never exceed the relative maximum operating pressure of 3.5 bar.



With this system, the delivery pipe must be equipped with a check valve (1) to prevent water from backing up into the rotary blades vacuum pump.

3.3 ASSEMBLY AND FITTING - INSTALLATION

The Rotary blades vacuum pump should be assembled and installed using the following procedure:

- 1) Assemble the Rotary blades vacuum pump horizontally with its feet facing downwards. The assembly position on the vehicle should be easy to access and be protected. A 5° maximum longitudinal slope of the Rotary blades vacuum pump with respect to the horizontal plane must not be exceeded.
 - 2) Bolt the Rotary blades vacuum pump using screws and nuts passing through the specially provided slots or holes in the feet;
- 3-M/K)** To install the .../M-K version Rotary blades vacuum pump, connect the cardan shaft at 540 r.p.m. of the tractor to the P.T.O. shaft of the Rotary blades vacuum pump.
- 3-MA/KA)** To install the .../MA-KA version Rotary blades vacuum pump, connect the cardan shaft at 1000 r.p.m. of the tractor to the P.T.O. shaft of the Rotary blades vacuum pump.



Don't exceed the maximum slope allowed for the cardan shaft.



3-P) To install the .../P version Rotary blades vacuum pump, attach a driven pulley to the shaft and fix it with the special screw located on the front of the shaft. The driven pulley may be fitted directly on the cylindrical shaft if the radial load is brought close to the bearing. Never transfer axial loads. Then connect the driven pulley to the driving pulley with the correct length of driving belts. The number and type of belts must be calculated according to the power to be transferred to the Rotary blades vacuum pump. When this operation has been completed, the necessary guard must be installed to isolate the driving parts (pulleys and belts) and prevent access to them by the operators.

- The best tension is the lower one where the belt doesn't slide under max loading condition
- Check frequently the tension during first 24/48 hours of running phase
- The over-tension reduces the life of belt and bearing
- Keep belts free from any material which may cause sliding
- Check periodically the transmission. Set it when sliding

To check the tension on a normal transmission, do what follows:

- measure the length of free stretch (t)
 - In the middle of free stretch of the belt (t) apply a force(perpendicular to free stretch) nought to bend the belt 1.6 mm per 100 mm in length of the free. For example, the decline of a free stretch of 1000 mm is 16 mm.
 - Compare the force you have applied and measured through a instrument with datas stated under our table. If the force is included between "minimum force" datas, it means that the belt is not enough stretched.
- If the force exceeds "max force" datas, it means that the belt is too stretched.

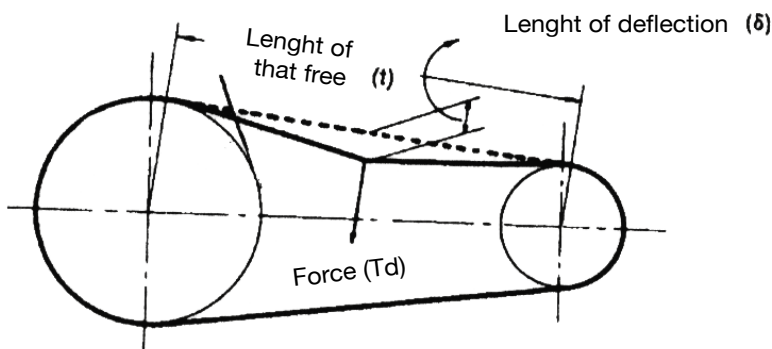

Section	Force	
	Min	Max
	Kg.	Kg.
A	0,68	1,02
B	1,58	2,38
C	2,93	4,75
D	5,77	8,61
E	9,60	14,30

3-D) To install the .../D version Rotary blades vacuum pump, connect the cardan shaft at 1000 rpm of the tractor to the P.T.O. shaft of the Rotary blades vacuum pump.



Don't exceed the maximum slope allowed for the cardan shaft.

3-H) To install the .../H version Rotary blades vacuum pump, attach an hydraulic motor (flanging European unification - Group 3,5 for MEC 2000-3000-4000-5000-6500-8000 series and Group 4 for STAR, AGRI and MEC 9000-11000-13500 series) to the power take-off shaft and fix it, using special screws, to the cast iron support located at the front.

3.4 HYDRAULIC DRAFT (/H version)

The hydraulic system required for the operation of Rotary blades vacuum pump .../H is schematized in Figure 3 and the technical characteristics of the hydraulic motor are shown in Table 2.

The splining of the hydraulic motor is of a type DIN 5482 - Z=23 for MEC 9000-11000-13500, STAR, and AGRI series and of type DIN 5482 - Z=20 for MEC 2000-3000-4000-5000-6500-8000 series.

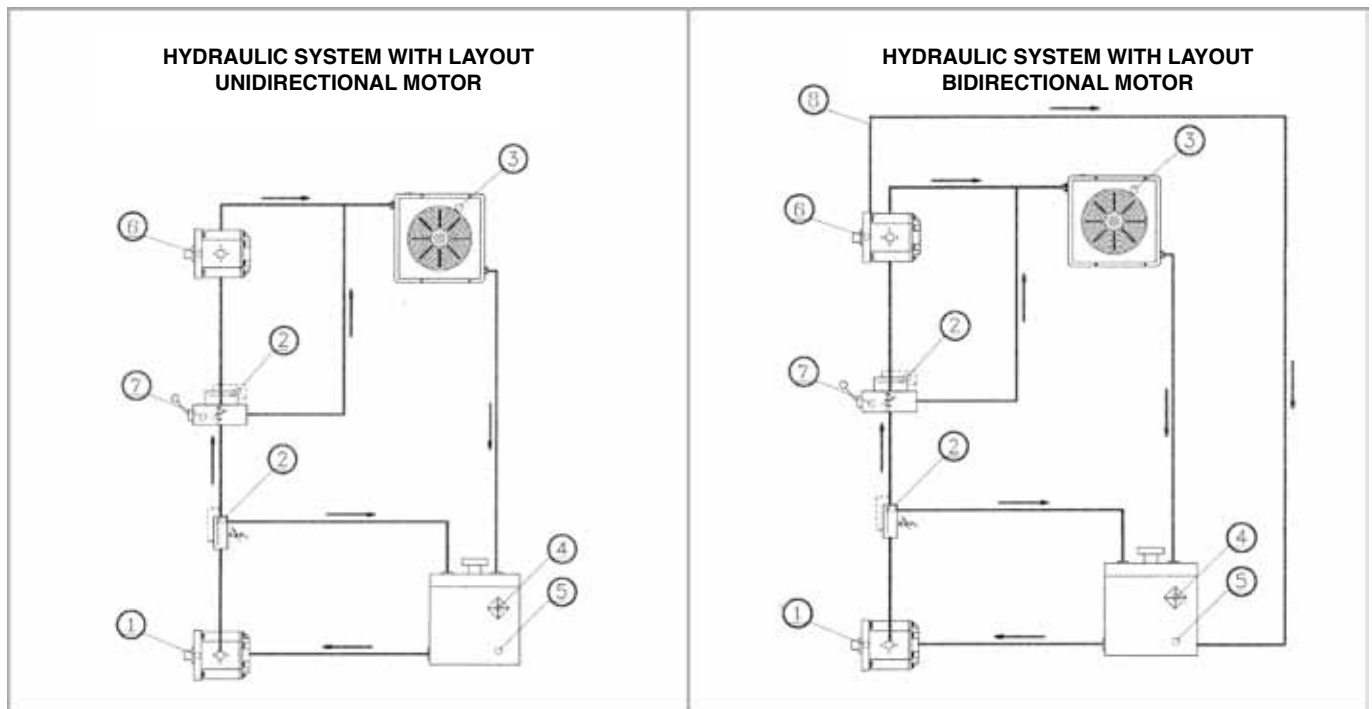
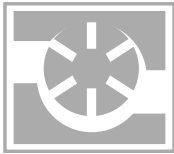

- 1 Hydraulic pump**
- 2 Over-pressure valve**
- 3 Radiator**
- 4 Oil filter**

- 5 Oil tank**
- 6 Hydraulic motor**
- 7 Distributor**
- 8 Drainage**

4) Then connect the intake/compression pipe of the tank car to the Rotary blades vacuum pump tightening it to the adjustable elbow using metal clamping bands in relation to the diameter of the pipe.

3.5 HYDRAULIC MOTOR INSTALLATION INSTRUCTION

Make sure take the rotation of the unidirectional motor is the proper are for your system. Make sure take this is a good linear matching between motor shift and power take off.

TANK. Tank capacity must be sufficient for the system's operating conditions (~ 3 times the amount of oil in circulation) to avoid overheating of the fluid. A heat exchanger should be installed if necessary. The intake and return lines in the tank must be spaced apart (by inserting a vertical divider) to prevent the return-line oil from being taken up again immediately.

LINES. The lines must have a major diameter which is at least as large as the diameter of motor or pump ports, and must be perfectly sealed. To reduce loss of load, the lines should be as short as possible, reducing the sources of hydraulic resistance (elbow, throttling, gate valves, etc.) to a minimum. A length of flexible tubing is recommended to reduce the transmission of vibrations. All return lines must end below the minimum oil level, to prevent foaming. Before connecting the lines, remove any plugs and make sure that the lines are perfectly clean.

FILTERS. We recommend filtering the entire system flow rate. Filters should be fitted as indicated in the first pages of the catalogue. Only coarse filters are recommended for pump intake.

HYDRAULIC FLUID. Use hydraulic fluid conforming to ISO/DIN standards, having viscosity as specified in the first pages of the catalogue. Avoid using mixtures of different oils which could result in decomposition and reduction of the oil's lubricating power.



DRAIN HOLE: on bi-directional motors with drain hole, the hole has to be connected to the oil tank through an hose of at least 22 mm of diameter. To avoid the forming of foam inside the tank, the hose has to be connected under the minimum level.

STARTING UP. Check that all circuit connections are exact and that the entire system is completely clean. Insert the oil in the tank, using a filter. Bleed the circuit to assist in filling. Set the pressure relief valves to the lowest possible setting. Turn on the system for a few moments at minimum speed, then bleed the circuit again and check the level of oil in the tank. If the difference between pump or motor temperature and fluid temperature exceeds 10 °C, rapidly switch the system on and off to heat it up gradually. Then gradually increase the pressure and speed of rotation until the pre-set operating levels as specified in the catalogue are attained.

PERIODICAL CHECKS – MAINTENANCE Keep the outside surface clean especially in the area of the drive shaft seal. In fact, abrasive powder can accelerate wear on the seal and cause leakage. Replace filters regularly to keep the fluid clean. The oil level must be checked and replaced periodically dependig on the system’s operating conditions.

RESOLUTION PROBLEMS:

- Circuit is open. Downstream of the engine you have the oil reservoir and not the pump. If the engine remained in rotation with the engine off, there will be overpressure, but cavitation. To solve this problem it would take a one-way valve that lists the oil or some of it through calibration, the engine sent to his desire to avoid that the engine air pump.

- Circuit is closed. You could have an overpressure. To solve the problem or put an overpressure valve, as recommended in the key facility attached or a calibrated one-way valve that bypasses the engine. Compared to the first case, the last option is cheaper and less invasive on a system already exists as it does not require an additional hole in the tank.

HYDRAULIC MOTOR										
Hydraulic Motor	Rotary blades vacuum Pump	Max pressure of exercise	Flow rate	Rpm	Pressure	Max pressure Hydraulic system	Trasmitted Power	Torque		
KM 30.51-SO	MEC 2000/H	1,5 bar	74,8 l/min	1 4 0 0	78 bar	230 bar	8 kW	57 Nm		
	MEC 3000/H				107 bar		11 kW	78 Nm		
	MEC 4000/H				136 bar		14 kW	99 Nm		
	MEC 5000/H				165 bar		17 kW	120 Nm		
	MEC 6500/H				204 bar		21 kW	148 Nm		
	MEC 8000/H				218 bar		22,5 kW	158 Nm		
KM 40.87-SO	MEC 9000	1,5 bar	125 l/min	1 4 0 0	174 bar	280 bar	30 kW	211 Nm		
	MEC 11000				186 bar		32 kW	226 Nm		
	MEC 13500				198 bar		34 kW	240 Nm		
KM 40.87-SO	WPT 480/H	1,5 bar	107 l/min	1 2 0 0	210 bar	280 bar	31 kW	255 Nm		
	WPT 600/H				237 bar		35 kW	287 Nm		
	WPT 720/H				264 bar		39 kW	320 Nm		
	AGRI/STAR 60/H				197 bar		29 kW	239 Nm		
	AGRI/STAR 72/H				210 bar		31 kW	255 Nm		
	AGRI/STAR 84/H				258 bar		38 kW	312 Nm		

Table 1

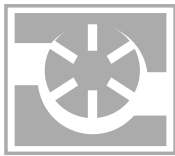

3.6 DISINSTALLATON

The Rotary blades vacuum pump should be disinstalled using the following procedure:

.../M-K	.../P	.../D	.../H
1) Stop the power take-off of the tractor;	1) Stop the power take-off of the tractor;	1) Stop the power take-off of the tractor;	1) Stop the hydraulic system;
2) Remove the cardan shaft from the power take-off of the rotary blades vacuum pump;	2) Remove the driving belts.	2) Remove the cardan shaft from the power take-off of the rotary blades vacuum pump.	2) Remove the hydraulic connections to the motor.
3) Remove the connecting pipe that joins the rotary blades vacuum pump to the tank car, by loosening the metal band and sliding the pipe from the adjustable elbow;	3) remove the pipe that connects the rotary blades vacuum pump to the tank car. To accomplish this, loosen the metal clamp and pull the pipe out of the elbow;	3) remove the pipe that connects the rotary blades vacuum pump to the tank car. To accomplish this, loosen the metal clamp and pull the pipe out of the elbow;	3) remove the pipe that connects the rotary blades vacuum pump to the tank car. To accomplish this, loosen the metal clamp and pull the pipe out of the elbow;
4) Remove any hydraulic connections;	4) remove any plumbing connections;	4) remove any plumbing connections;	4) remove any plumbing connections;
5) Remove the clamping screws and disinstall the rotary blades vacuum pump.	5) remove the mounting screws and remove the rotary blades vacuum pump.	5) remove the mounting screws and remove the rotary blades vacuum pump.	5) remove the mounting screws and remove the rotary blades vacuum pump.

3.7 DISASSEMBLY

3.7.1 Back disassembly

SERIE MEC 1000-1600-2000-3000-4000-5000-6500-8000

- 1) Remove the back cover or the lubrication pump (together with the connector joint) from the flange;
- 2) Remove the screws from the back flange;
- 3) Use two screws for screwing into the threaded extraction holes until the flange is removed;

SERIE MEC 9000-11000-13500

- 1) Remove the rear cover or oil pump (together with the connecting joint) from the flange;
- 2) Remove the seeger ring from the rear pin;
- 3) Remove the screws from the rear flange.
- 4) Screw two screws into the threaded extraction holes just until the flange can be removed;

STAR - AGRI /V (with rear cast iron oil tank)

STAR - AGRI /F (with rear flange and extractable side sheet oil tank)

- | | |
|---|---|
| <ol style="list-style-type: none"> 1. Remove the tank cover and the lubrication pump (together with the connector joint) from the back tank; 2. Remove the screws from the back tank; 3. Use two screws for screwing into the threaded extraction holes until the tank is removed; | <ol style="list-style-type: none"> 1. Close the oil cock placet on the tank 2. Remove the back cover with the lubrication pump (together with the connector joint) from the flange; 3. Remove the screws from the back flange; 4. Use two screws for screwing into the threaded extraction holes until the flange is removed; |
|---|---|



3.7.2 Front disassembly

.../M-K	.../P	MEC 9000-11000-13500.../P	.../D	.../H
1) Unscrew the screws of the gearbox cover;	1) Remove the driven pulley and the key;	1) Remove the driven pulley and the key;	1) Remove the flange with splined shaft;	1) Disassemble the hydraulic motor from its support;
2) Use two screws for screwing into the threaded extraction holes until the cover is removed;	2) Disassemble the front cover from the flange;	2) Remove the front cover from the flange;	2) Remove the sleeve with transmission flange and key	2) Remove the hydraulic motor support;
3) Remove the gear with splined shaft using an extractor if necessary;	3) Remove the screws from the front flange;	3) Remove the seeger ring from the front pin;	3) Remove the seeger ring placed in front of the bearing;	3) Remove the clamping screw located inside the sleeve and then slide the sleeve out;
4) For the pinion: unscrew the self-locking nut, use an extractor;	4) Slide the rotor from the body;	4) Remove the screws from the front flange.	4) Remove the clamping screw from the splined hub;	4) Remove the screws from the front flange;
5) Remove the seeger ring placed in front of the bearing	5) Remove the seeger ring placed in front of the bearing;	5) Pull the rotor out from the body;	5) Disassemble the rotor from the gearbox through a press	5) Slide the rotor from the body;
6) Slide the rotor from the body together with the gearbox;	6) Disassemble the rotor from the gearbox through a press;	6) Use a press to remove the rotor from the flange.		6) Remove the seeger ring placed in front of the bearing;
7) Disassemble the rotor from the gearbox through a press;				7) Disassemble the rotor from the gearbox through a press;

3.8 RE-FITTING – RE-INSTALLATION



IMPORTANT: Before proceeding with any re-fitting, replace the gaskets of the opened parts.

3.8.1 Re-fitting of the back

SERIE MEC 1000-1600-2000-3000-4000-5000-6500-8000

- 1) Remove the bearing and the spacer from the back flange;
- 2) Replace the flange gasket;
- 3) Bring the back flange up to the pump body, aligning it with the clamping holes;
- 4) Insert the 6 clamping screws in the holes and tighten them;
- 5) Fit the bearing on the flange using a drift;
- 6) Insert the spacer;
- 7) Re-fit the back cover or the lubrication pump (together with the connector joint) on the flange.



SERIE MEC 9000-11000-13500

- 1) Remove the bearing from the rear flange;
- 2) Insert the two centering pins into the pump body;
- 3) Replace the seal on the flange;
- 4) While lining up the holes with the two pins, bring the rear flange and the pump body together;
- 5) Insert the 6 mounting screws into the slotted holes and tighten to $45 \div 55$ Nm;
- 6) Using a mallet, install the bearing on the flange;
- 7) Install the seeger ring on the rear pin;
- 8) Install the rear cover or oil pump (together with the connecting joint) back onto the flange;
- 9) Remove the centering pins.



Figure A

The MEC 9000/11000/13500 pump is equipped with a system that allows the flange to slide, which prevents breakage if foreign bodies become lodged between the rotor and the pump body. (Except for version G-GA)

To benefit from this system, it is important to follow these instructions:

Before starting the pump, make sure the rotor has not dropped down accidentally. This can be accomplished by making sure the cut in the flange lines up with the cut machined into pump body (see figure A).

STAR-AGRI /V (with rear cast iron tank)	STAR-AGRI /F (with later tank)
1. Remove the bearing from the back tank;	1. Remove the bearing from the back flange;
2. Replace the pump body gasket;	2. Replace the pump body gasket;
3. Bring the back tank up to the pump body, aligning it with the clamping holes;	3. Bring the back flange up to the pump body, aligning it with the clamping holes;
4. Insert the clamping screws in the holes and tighten them;	4. Insert the clamping screws in the holes and tighten them;
5. Fit the bearing on the tank using a drift;	5. Fit the bearing on the flange using a drift;
6. Put back the tank cover and the lubrication pump (together with the connector joint) on the back tank;	6. Put back the back cover and the lubrication pump (together with the connector joint) on the back flange;
7. Fill up the oil tank with oil for lubrication;	7. Open the cock placed on the side tank

3.8.2 3.8.2 Re-fitting of MEC 1000-1600-2000-3000-4000-5000-6500-8000 /STAR/AGRI manifold

1. Replace the manifold gasket;
2. Position the manifold on the pump body;
3. Tighten the clamping screws of the manifold.
4. Fit the reversing gear;
5. Fit the spring onto the reversing gear;
6. Replace the gasket onto the cover with sleeve;
7. Place the cover with sleeve onto the manifold;
8. Tight the fixing screws of the cover;
9. Assemble the handle.

Reinstalling MEC 9000-11000-13500 manifold

- 1) Replace the gasket on the manifold;
- 2) Position the manifold on the pump body;
- 3) Tighten the mounting screws on the manifold;
- 4) Install the reverse gear;
- 5) Install the spring on the reverse gear;
- 6) Install the spacer onto the spring on the reverse gear;
- 7) Replace the gasket on the manifold cover;
- 8) Position the manifold cover on the manifold;
- 9) Tighten the mounting screws on the manifold cover;
- 10) Install the oil seal into its seat on the manifold cover;
- 11) Install the handle and tighten it using the screw provided;





3.8.3 Re-fitting of the front

.../M-MA-K-KA	.../P	.../D	.../H
1) Mec 5000-6500-8000-9000-11000-13500: remove the seeger;	1) Remove the seeger;	1) Remove the seeger;	1) Remove the seeger;
1) Star/Agri: disassemble no. 3 screws;	2) Remove the bearing;	2) Remove the bearing;	2) Remove the bearing;
2) Disassemble the bearing;	3) Disassemble bearing and seeger rign;	3) Disassemble bearing and seeger rign;	3) Disassemble bearing and seeger rign;
3) Replace the flange gasket;	4) Mec 9000-11000-13500: insert the pins (supplied with the unit) into the pump body;	4) Mec 9000-11000-13500: insert the pins (supplied with the unit) into the pump body;	4) Mec 9000-11000-13500: insert the pins (supplied with the unit) into the pump body;
4) Mec 9000-11000-13500: install the pins (supplied with the unit) into the pump body;	5) Replace the flange gasket;	5) Replace the flange gasket;	5) Replace the flange gasket;
5) Fix the gearbox to pump body trough screws	5) Mec 9000-11000-13500: mount the front flange on the pump body using screws tightened to 45 ÷ 55 Nm;	5) Mec 9000-11000-13500: mount the front flange on the pump body using screws tightened to 45 ÷ 55 Nm;	5) Mec 9000-11000-13500: mount the front flange on the pump body using screws tightened to 45 ÷ 55 Nm;
5) Mec 9000-11000-13500: mount the gearbox on the pump body using screws tightened to 45 ÷ 55 Nm;	6) Using a buffer, install the bearing onto the flange and install the seeger;	6) Using a buffer, install the bearing onto the flange and install the seeger;	6) Using a buffer, install the bearing onto the flange and install the seeger;
6) Using a buffer, install the bearing onto the flange and install the seeger;	6) Mec 9000-11000-13500: using a buffer, install the bearing onto the flange, install the compensation ring and install the seeger;	6) Mec 9000-11000-13500: using a buffer, install the bearing onto the flange, install the compensation ring and install the seeger;	6) Mec 9000-11000-13500: using a buffer, install the bearing onto the flange, install the compensation ring and install the seeger;
6) Mec 9000-11000-13500: using a buffer, install the bearing onto the flange, install the compensation ring and install the seeger;	7) Put the front cover back on the flange.	7) Put the front cover back on the flange.	7) Put the transmission sleeve back on the rotor pin;
7) Mec 9000-11000-13500: install the spacer and mount the pinion on the shaft;	8) Mec 9000-11000-13500: remove the centring pins from the pump body.	8) Re-fit the splined hub;	8) Re-fit the hydraulic motor support;
7) Assemble the pinion onto the shaft;		9) Mec 9000-11000-13500: remove the centring pins from the pump body.	9) Mec 9000-11000-13500: remove the centring pins from the pump body.
8) Fit the self-locking nut for fixing the pinion;			
9) Insert the gear in the bearing housing;			
10) Fit the gearbox cover;			
11) Fill up the gearbox with oil			
12) Mec 9000-11000-13500: remove the centring pins from the pump body.			



The MEC 9000/11000/13500 pump is equipped with a system that allows the flange to slide, which prevents breakage if foreign bodies become lodged between the rotor and the pump body. (Except for version G-GA)

To benefit from this system, it is important to follow these instructions:

Before starting the pump, make sure the rotor has not dropped down accidentally. This can be accomplished by making sure the cut machined into flange lines up with the cut machined into pump body.



Flange slot



Cut for aligning flange with pump body

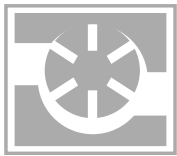

3.8.4 CORRECT POSITIONING OF REVERSING GEAR

To position the reversing gear correctly, follow the procedure below:

1. remove the handle (MEC series) or the reversing selector;
2. remove the manifold cover;
3. check that the flat part of the reversing gear is positioned at 45° to the power take-off;
4. re-fit the manifold cover and the handle (MEC series) or the reversing selector.

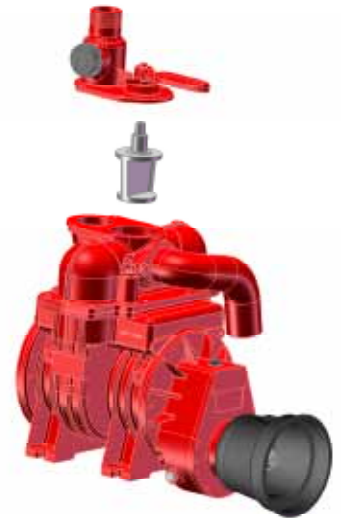

4 - REVERSION OF DIRECTION OF ROTATION – ROTARY BLADES VACUUM PUMP WITH FORCE FEED OR AUTOMATIC LUBRICATION

If it is necessary to reverse the direction of rotation of a rotary blades vacuum pump with automatic lubrication, proceed as follows:

- disassemble the back cover and the automatic lubrication pump DX or SX (together with the coupling joint) from the flange;
- remove the screws from the back flange;
- use two screws in the threaded extraction holes until the flange is removed;
- remove the screws from the front flange;
- extract the rotor from the body together with the front flange;
- rotate the body together with the manifold 180° on a horizontal level;
- replace two flange gaskets;
- slide the rotor in the body together with the front flange;
- tighten the six securing screws of the front flange to the body;
- disassemble the bearing and the seeger from the back flange;
- approach the back flange to the pump body, positioning it on a level with the securing holes;
- insert the six securing screws in the holes and tighten;
- assemble the bearing on the flange by means of a stopper and fit the seeger;
- insert the spacer;
- re-assemble the back cover and replace the automatic lubrication pump DX or SX with another one with opposite direction of rotation (together with the coupling joint) to the flange.

In case of a rotary blades pump (**STAR** or **AGRI**) series with force feed lubrication, please follow the same instructions for pumps with automatic lubrication; while for rotary blades pump (**MEC**) series with force feed lubrication it is not necessary to replace the lubrication pump as it is bi-directional.

5 - START-UP

5.1 WORKING/RUNNING WITHOUT OVERPRESSURE VALVE – MEC SERIES



Before starting the rotary blades vacuum pump make sure that the hole in the manifold cover made for the overpressure valve is closed with a cap, if the overpressure and depression valves are present and working in the installation. If overpressure and depression valves are not fitted on their hole onto the rotary blades pump, close the hole by means of a cap.

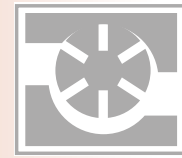

5.2 DIRECTION OF ROTATION



Before starting the Rotary blades vacuum pump make sure that the P.T.O. shaft turns freely and that the direction of rotation is the same as the one indicated by the arrow.

Never turn the rotary blades vacuum pump in the direction of rotation opposite to the one for which it has been prepared (indicated by the arrow) as this could damage some components as well as prevent the operation of the pump.

6 - SET-UP OF THE LUBRIFICATION SYSTEM

Three different types of lubrication have been developed for the Rotary blades vacuum pump (see Figure 3).

6.1 NORMAL LUBRICATION

Lubrication occurs during the intake phase only. The vacuum created in the Rotary blades vacuum pump sucks oil from the tank. In the compression phase lubrication occurs with the residue of oil from the preceding phase. Normal lubrication is available only for models MEC 1000 and MEC 1600 that are manufactured with only this type of lubrication.

6.2 FORCED LUBRICATION

Lubrication occurs in both the intake phase and the compression phase through a gear pump placed at the back and actuated by the rotor shaft. The gear pump sucks oil from the tank and sends it to the manually adjusted metering tap. Excess oil returns to the tank through a tube connecting the tap to the tank. Forced lubrication is available as standard feature on models MEC, STAR, AGRI.

6.3 AUTOMATIC LUBRICATION

With this system lubrication occurs in both the intake phase and the compression phase by means of a piston metering pump with adjustable flow rate placed at the back and actuated by the rotor. The oil is injected directly into the Rotary blades vacuum pump, eliminating manual adjustment and saving a considerable amount of oil. Automatic lubrication is supplied, on request, on models MEC, STAR, AGRI.

Figure 3

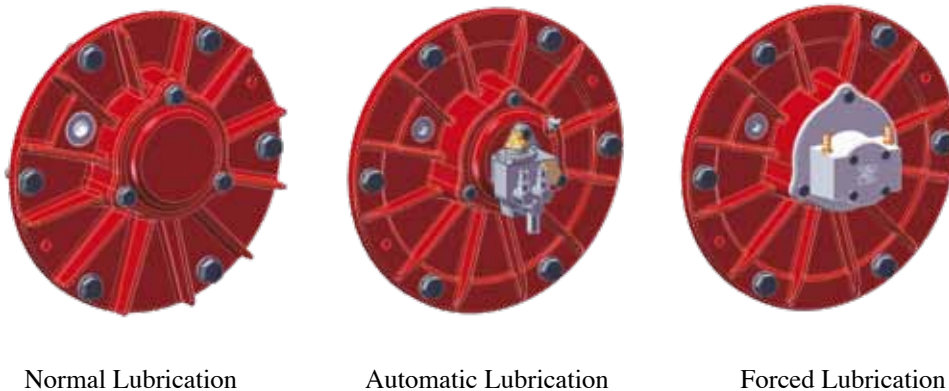

6.4 OIL TO USE

The Rotary blades vacuum pump are supplied without lubrication oil in the oil tank. BPP suggest to use “Battioni Pagani vacuum pump oil” for internal lubrication. It grants.

- Excellent resistance to oxidation
- Strong anti-rust property
- Excellent anti foam power
- Working temperature from -5 °C to 160 °C

IF “VACUUM PUMP OIL” IS NOT AVAILABLE, USE ONLY NEW MINERAL OIL MEETING ISO VG 100 (SAE 30)

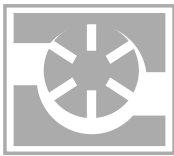

6.4.1 ABSOLUTELY DO NOT USE FOLLOWING OIL TYPES:





TRASMISSION OIL - USED OIL - HYDRAULIC OIL - VEGETABLE OIL -
OIL FOR GEARS - OIL FOR BRANKES

YOU MUST USE ONLY NEW OIL

6.4.2 GEARBOX OIL

All M-MA-K-KA versions (with gearbox) are equipped with oil into the gearbox.
If you have to change the oil use only ISO VG 460.

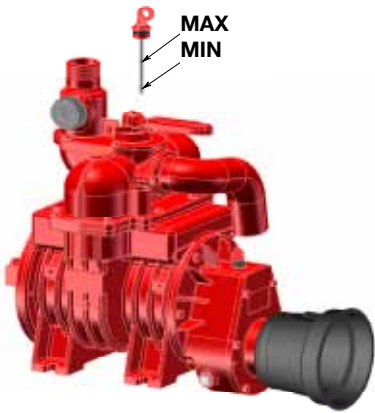
6.5 OIL LEVEL

MEC SERIES	STAR/V, AGRI/V SERIES	STAR/F, AGRI/F SERIES
 <p>Figure 4</p>	 <p>Figure 5</p>	 <p>Figure 6</p>

SERIE MEC

For internal lubrication, the minimum oil level is indicated by the notch at the lower end of the level rod (see Figure 4) located on the manifold and consequently the maximum level will be reached when the tank is full.

SERIE STAR/V, AGRI/V

For internal lubrication, the minimum oil level is indicated by the total length of the plug with level rod (see Figure 5) situated in the back tank and the maximum level will be reached with a full tank.

Serie STAR/F, AGRI/F

For internal lubrication, the minimum oil level is indicated by the lower notch on the indicator placed at the side of the external tank (see Figure 6) and the maximum level will be reached with a full tank

OIL TANK CAPACITY [L]							
MEC 1000	MEC 1600	MEC 2000	MEC 3000	MEC 4000	MEC 5000	MEC 6500	MEC 8000
0,6	0,7	1,0	1,2	1,5	2,5	3,1	3,8
MEC 9000	MEC 11000	MEC 13500	STAR/AGRI			STAR-AGRI/F	
2,5	3	3,5	3,7			4,3	

Table 2

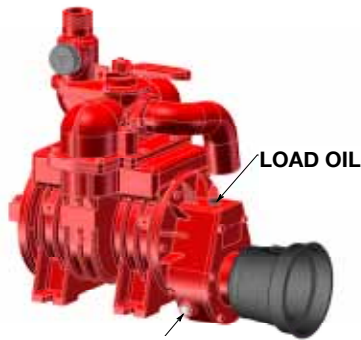

M – MA – K – KA VERSIONS: the gearbox has an oil loading plug at the top of the gearbox and an oil level plug (see Figure 7), placed on the side of the gearbox to allow the level to be checked

To ensure correct lubrication, the oil should always be visible in the oil level.

Figure 7

6.6 QUANTITY OF LUBRICATION OIL

When the Rotary blades vacuum pump is running, check that the quantity of oil indicated in Table 4 is dripping from the special regulator tap. These quantities are valid for both Forced and Automatic Lubrication. When necessary, add only unused clean oil to the tank.

/M – MA – K - KA VERSIONS: make the first oil change in the gearbox after approx. 100 working hours and subsequent changes approx. every 300 working hours.

MODEL	Drop/min at max vacuum	Drop/min air flow free air	g/h at max vacuum	g/h air flow free air
MEC 1000	20 - 25	10 - 12	50	25
MEC 1600	20 - 25	10 - 12	50	25
MEC 2000	25 - 30	12 - 15	63	32
MEC 3000	25 - 30	12 - 15	63	32
MEC 4000	25 - 30	12 - 15	63	32
MEC 5000	30 - 40	15 - 20	80	40
MEC 6500	40 - 50	20 - 25	100	50
MEC 8000	40 - 50	20 - 25	100	50
MEC 9000	50 - 60	25 - 30	120	60
MEC 11000	50 - 60	25 - 30	120	60
MEC 13500	50 - 60	25 - 30	120	60

MODEL	Drop/min for each drain cock at max vacuum	Drop/min for each drain air flow free air	g/h for each drain cock at max vacuum	g/h for each drain air flow free air
STAR 60	30 - 40	15 - 20	80	40
STAR 72	35 - 45	17 - 22	90	45
STAR 84	40 - 50	20 - 25	100	50
AGRI 60	30 - 40	15 - 20	80	40
AGRI 72	35 - 45	17 - 22	90	45
AGRI 84	40 - 50	20 - 25	100	50

Table 3



6.7 REGULATION FOR LUBRICATING OIL

To adjust the dripping of oil in the Rotary blades vacuum pump with forced lubrication, turn the regulator ring nut “A” (see Figure 8) after loosening ring nut “B”.

Tighten ring nut “B” again when adjustment has been completed.

The adjustment of oil delivery, in automatic lubrication, is carried out at our factory during final testing of the Rotary blades vacuum pump.

If, for any reason, a different setting is required proceed as follows: remove pin cover “B” (see Figure 9), loosen lock nut “C” and then turn regulator pin “A”.

By rotating clockwise lower oil delivery is obtained (-), and by rotating anticlockwise higher oil delivery is obtained (+). When adjustment has been completed tighten lock nut “C” and screw cover.

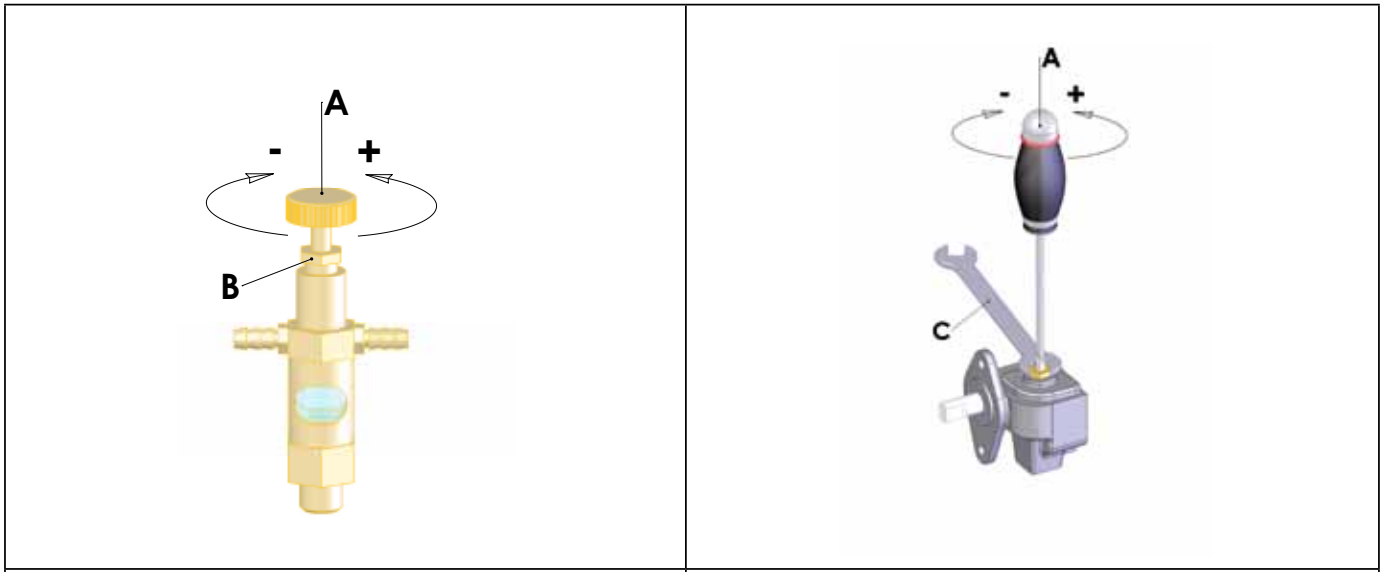

Figure 8 **Figure 9**

7 – OVERPRESSURE AND VACUUM ADJUSTMENT VALVES

The following diagram describes the valves as series (O), on demand (X) and not available (-) for each model of rotary blades vacuum pump.

	VACUUM ADJUSTMENT VALVE 1" 1/2	OVERPRESSURE VALVE 1" 1/4	OVERPRESSURE VALVE 1" 1/2	OVERPRESSURE VALVE 2"
MEC 1000/1600	-	-	-	-
MEC 2/3/4000	-	X	-	-
MEC 5/6.5/8000	X	-	X	-
MEC 9/11/13500	X	-	-	X
STAR 60/72/84	O	-	-	X
AGRI 60/72/84	O	-	-	X

O = As Series

X = on request

- = Not available

Table 4

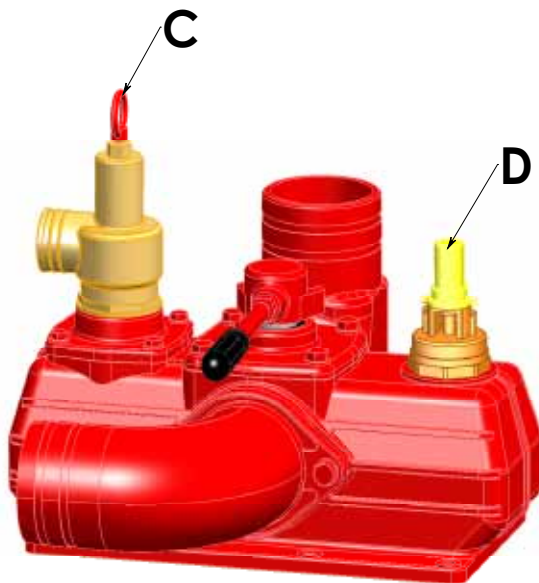

ATTENTION: the installation must be always equipped with depression valve (set at $-0,80$ bar) and with overpressure valve (set at 1 bar).

Pressure: the maximum allowed pressure is 2,5 absolute bar (1,5 relative bar). In order to avoid exceeding this value or to obtain a lower max pressure, an overpressure valve, "C", must be applied that is of a size capable of discharging the excess air delivery.

Vacuum: too high a vacuum may cause ovality and waviness of the body or breaking of the blades. It is therefore advisable to use a vacuum regulator valve, "D". These valves may be fitted on the manifold cover or on manifold of the Rotary blades vacuum pump. Vacuum working degree is of $-0,80$ bar.

The regulation of the valves is done by acting on the throttle placed on the valve same (overpressure valve) or action on nut and locknut (vacuum adjustment valve).

Figure 10

8 - TESTING AND RUNNING IN

8.1 TESTING

All the Rotary blades vacuum pump Battioni Pagani are tested before the delivery at our plant.



In order to test the Rotary blades vacuum pump check the preceding points, using a workbench if necessary.

Make sure that the P.T.O. shaft turns freely and that the direction of rotation is the same as the one indicated by the arrow.



If operation of the pump is checked without it being connected to the suction/delivery tubes there will be danger to operators' hands due to access to the inside of the discharge elbow. In this situation there is also the danger that foreign bodies will be sucked into the machine.

Check that the position of the handle is correct and test that the Rotary blades vacuum pump exhausts or compresses.

8.2 RUNNING IN

The running in period foreseen for a rotary blades pump is of 30 of effective working. During that period the working parameters must be reduced of 20%

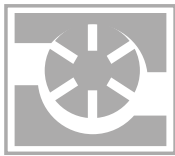

9 - START, OPERATION, STOP

9.1 START

The Rotary blades vacuum pump does not have a start button. Therefore to start it just transmit the motion to the power take-off (P.T.O.). The way this is done depends on the version of Rotary blades vacuum pump. Before starting make sure that the rotary blades vacuum pump is supplied with oil for internal lubrication (and lubrication of gearbox in versions .../M-MA and .../K-KA).



Before starting the rotary blades vacuum pump, make sure that the guards on all the moving parts are in place and efficient. Any damaged or missing components must be replaced and installed correctly before using the transmission.

For .../M-MA, K-KA, D version clean and grease the power take off before to install the cardan transmission.

9.2 OPERATION



Do not use the Rotary blades vacuum pump at pressures, temperatures, times higher than those indicated in Table 6. During use do not exceed the speed and power limits set in this manual. Do not overload the machine or suddenly engage the P.T.O.

Check the following operating parameters.

PARAMETER		WORKING RATE	MAXIMUM RATE
Revs M, K	[rpm]	450-500	600
Revs P, D, H,	[rpm]	1000	1200
Revs MA, KA	[rpm]	800	1000
Pressure	[bar]	0,5 – 1	1,5
Vacuum	[%]	80 %	95 %
Outside temperature side cylinder compression [°C]		80 – 90	130
Time	[min]	3-5	6-8
Working time with long life blades [min]		6-8	15
Working time ballast version -0,65 bar		continuous	continuous

Table 5



Failure to comply with the instructions given in this manual may be dangerous for the user health or may damage the rotary blades vacuum pump. If density of material to suck is high, dilute or mix the material same. The working time should be such that the maximum temperature is never reached. Prolonged operation without interruption may cause damage to the blades as well as overheating.



9.3 STOP

To stop the rotary blades vacuum pump, stop the engine and disconnect the P.T.O. in order to prevent accidental operation of it.

9.4 CONTROLS

A handle, located at the top of the manifold, is provided for the control of intake and compression phases. This can be operated manually. To state in which direction the handle has to be turned to select suction or compression phase, follow the instructions given by the manufacturer of the installation. If the reverse gear locks up, use a lever to lift the handle.



Selection of the intake or compression phase with the handle must be made with the Rotary blades vacuum pump not operating.

9.5 TEMPERATURE INDICATOR (THERMO TAPE)

Thermo Tape is affixed on the compression side of all Mec 9000-11000-13500 versions.

This temperature indicator provides two temperature readouts:

- The reversible scale at the bottom changes colour (from black to blue) at a specific temperature (90 ° C to 120 ° C). The scale is provided to help the user prevent the pump from overheating.
- A blue square with a white dot at the centre (a non-reversible indicator) is located at the upper right on the scale. If the dot turns black, the temperature has exceeded 160 ° C, which means the pump has been used for more than 15 minutes at its maximum vacuum level (which is an incorrect use). If this occurs, the pump must be disassembled and all the seals, oil seals and blades must be replaced.

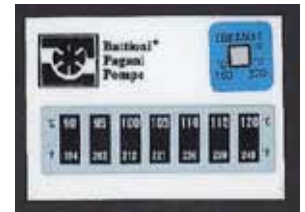

9.6 PROTECTIVE DEVICES



The Rotary blades vacuum pump, when being installed on a machine, must be equipped with a protective device to isolate the moving parts and prevent access to them by the operators.



It is necessary to protect the Rotary blades vacuum pump to avoid the remote danger of material projection in case of heavy breakage.

.../M-MA, K, KA and D versions are equipped with a CE plastic protective device. It insulates and protects the P.T.O. shaft during moving

9.7 INDIVIDUAL MEANS OF PROTECTION TO BE USED



When operating the Rotary blades vacuum pump, it is necessary to use the individual means of protection prescribed by the Manufacturer of the machine on which the Rotary blades vacuum pump has been installed.

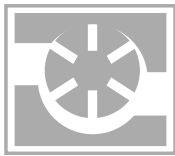

10 - TROUBLESHOOTING

PROBLEM	CAUSE	REMEDY
Little vacuum or pressure	Blades are worn	Replace blades
	Some blades jammed in rotor	Disassemble rotary blades vacuum pump, clean and wash rotor, blades, and body
	Air infiltration or leakage from system	Eliminate infiltrations
	Undulated cylinder	Smooth or replace the body
	Reversing gear badly positioned	Remove reversing gear and position it correctly
	Flange assembly too tight	Add a gasket to the back flange
Overheating	Excessive pressure	Reduce pressure
	Excessive rate of revs	Reduce rate of revs
	Excessive operating time	Reduce operating time
	Blades too long	Trim blades to correct size
	Lack of lubrication	Check oil level in tank, oil pump operation, setting of oil tap
Beating against external surface	Rate of revs too low	Increase rate of revs
	Excessive/short and/or not suitable lubrication oil	Clean the rotary blades pump and replace the oil
Sewage comes out of discharge elbow	Malfunctioning of valves	Check valves
Smoke comes out of discharge elbow	Excessive lubrication	Adjust lubrication
No circulation of lubricating oil (for versions with automatic lubrication)	Air intake at pipe fittings	Replace pipe fittings
	Lubrication tube badly inserted in pipe fittings	Insert lubrication tube correctly
	Air in oil pump chamber	Fill pump chamber with oil
P.T.O. does not rotate	Broken blades	Replace blades (check if rotor pin is bent)
	Foreign body in rotary blades vacuum pump	Remove foreign body
No suction / no compression	Handle incorrectly positioned	Position handle correctly
	Reversing gear incorrectly positioned	Position reversing gear correctly
	Rotary blades vacuum pump rotates in wrong direction	Reverse direction of rotation
	All blades jammed	Disassemble rotary blades vacuum pump, clean and wash blades, rotor and body
	Blades protrude from the rotor slots anomalously	Disassemble rotary blades vacuum pump, clean and wash blades, rotor and body
	Rubber ball closes overflow valve	Increase passage of air inside valve



11 - MAINTENANCE, INSPECTIONS AND CHECKS, REPAIRS, TECHNICAL ASSISTANCE



When carrying out maintenance operations, inspections, checks or repairs it is advisable to wear the individual protective devices listed in this manual.



All maintenance operations, inspections, checks and repairs must be carried out with the greatest care and with the Rotary blades vacuum pump off and the P.T.O. disconnected.

11.1 CLEANING

11.1.1 WASHING OF THE BODY

If sewage enters the Rotary blades vacuum pump, the inside of the body must be washed immediately, by making it suck in diesel or fuel oil through the discharge elbow with the Rotary blades vacuum pump in compression phase. After this operation make it suck in oil. The same operation should be carried out when the Rotary blades vacuum pump has to remain inactive for a long time. In this case, disconnect the suction and delivery tube connected to the valves and hermetically seal the manifold cover because the gasses that form inside the tank would pass into the Rotary blades vacuum pump and cause the inside of the body to rust and this in turn could cause the blades to break when the system is re-started.

In order to avoid rust formation, do not use water.

If the body is washed after it is disassembled, it is advisable to carry out a preliminary wash with detergents (e.g. thinners) before carrying out the above operation.

11.1.2 WASHING OF OIL TANK

Wash the oil tank at least once a year. Remove the manifold, and then wash it using solvents.

11.1.3 WASHING AND CLEANING OF VALVES

Wash and clean the valves at least once a month. Remove the valves, then wash them with water or, if necessary, non-corrosive detergents.

11.2 CHECKING OF VALVES

Regularly check that all the valves, for both overflow and pressure/vacuum, are still working efficiently.

11.3 INSPECTION AND REPLACEMENT OF Blades

11.3.1 GENERAL INFORMATION ON BLADES

Three material type of blades are fitted on Rotary blades vacuum pump. The following Tabella 8 describes what kind of material is fitted for each series.

SERIES	STANDARD Blades	SPECIAL Blades
MEC 1000/8000	O	X
MEC 9/11/13500	-	O
STAR	O	X
AGRI	-	O

O = As series

X = On request

- = Not available

Table 8



Standard blades are suitable for no-strong uses, for short and not frequent periods.

Special blades are made of a special material suitable for strong uses and for Rotary blades vacuum pump used in agricultural field. These blades offer an excellent resistance to wear and mechanical and thermal stress. These are suitable for more frequent uses and to suck thick sewages. They are recommended for installation with frequent uses even during the same day.

Apart from normal wear, it may be necessary to replace the blades following incorrect use of the Rotary blades vacuum pump. The most frequent causes come from heat, lack of lubrication, entrance of sewage, high pressure or vacuum, formation of rust inside the body due to prolonged inactivity.

With the heat too high pallets stretch to touch the plate front and rear, this causes the breakdown of the pallets.

Lack of lubrication means the blades are completely dry like the inside of the pump. This increases their fragility and causes them to break lengthways.

The same type of breakage can be caused by entrance of sewage or by a too high working pressure.

A too high vacuum causes the blades to beat against the cylinder with consequent damage to the outside of the blades. Moreover, the lining becomes wavy.



Figure 11

11.3.2 INSPECTION OF BLADES MEC/STAR/AGRI

To check the state of wear of the blades in the Rotary blades vacuum pump proceed as follows:

- Remove the threaded inspection plug;
- Rotate the rotor until a blades lines up with the inspection hole;
- Compare the height of the blades with the reference ring on the rotor;
- Replace the entire set of blades when the height is less than the reference ring on the rotor.



11.3.3 REPLACEMENT OF BLADES

- 1) Check that there is sufficient space at the back of the Rotary blades vacuum pump to be able to work easily; if there is not, the Rotary blades vacuum pump should be taken off its support beforehand;
- 2) Remove the back
- 3) Extract the blades from the rotor;
- 4) Replace the blades;
- 5) Clean the Rotary blades vacuum pump.
- 6) Re-fit the back of the Rotary blades vacuum pump
- 7) Use original spare parts Battioni Pagani Pompe® only



Ask for Rebuild kit for rotary blades vacuum pump which is made of: original Battioni Pagani Pompe® blades, gaskets, oilseals in one blister only.



11.3.4 BLADES SIZES

MODEL	Blades NUMBER	Blades SIZE
MEC 1000	5	120x38x6,5
MEC 1600	5	190x38x6,5
MEC 2000	7	180x41x6,5
MEC 3000	7	240x41x6,5
MEC 4000	7	300x41x6,5
MEC 5000	7	300x46,5x6,5
MEC 6500	7	370x46,5x6,5
MEC 8000	7	450x46,5x6,5
MEC 5000 S.C.	5	299x46,5x9,7
MEC 6500 S.C.	5	369x46,5x9,7
MEC 8000 S.C.	5	449x46,5x9,7

MODEL	Blades NUMBER	Blades SIZE
MEC 9000	5	300x60x6,5
MEC 11000	5	370x60x6,5
MEC 13500	5	460x60x6,5
MEC 9000 S.C.	5	299x60x9,7
MEC 11000 S.C.	5	369x60x9,7
MEC 13500 S.C.	5	459x60x9,7
MEC 9000 ballast	8	300x60x6,5
MEC 11000 ballast	8	370x60x6,5
MEC 13500 ballast	8	460x60x6,5
STAR 60	6	350x70x7,5
STAR 72	6	400x70x7,5
STAR 84	6	480x70x7,5
AGRI 60	6	350x70x4,7
AGRI 72	6	400x70x4,7
AGRI 84	6	480x70x4,7

Table 9



IMPORTANT: check that blades received as spare parts have a length lower or equal to nominal measure stated under our Table 9

11.4 REPLACEMENT OF RUBBER BALL

1. Unscrew and raise the valve-holder cover (AGRI and STAR series) or the manifold (MEC series);
2. Replace the rubber ball;
3. Re-fit the valve-holder cover (AGRI and STAR series) or the manifold (MEC series).

11.5 REPLACEMENT OF GEARS (version /M - MA and /K - KA)

1. Unscrew the screws of the gearbox cover;
2. Use two screws for screwing into the threaded extraction holes until the cover is removed;
3. Take out the gear with splined shaft using an extractor if necessary;
4. For the pinion: unscrew the self-locking nut, use an extractor.

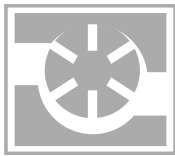

11.6 TECHNICAL ASSISTANCE

Contact the supplier of the complete system for technical assistance or supply of accessories and spare parts.

11.7 REGULAR SERVICING

SERVICING TO BE CARRIED OUT	HOW TO PROCEED	FREQUENCY
Check oil circulation	Inspect the level sight glasses	Once a day
Check oil level in tank	Use the oil level on outside of tank	Once a week
Check wear of blades	Remove threaded plug	Every 300 working hours
Check that the over-pressure and vacuum regulator valves are working correctly	Remove valves	Once a week
Wash oil tank	Remove tank	Once a year
Wash body internally	Put in oil + diesel oil (after washing lubricate with oil only)	Whenever sewage enters or when inactive for a long time
Wash lubrication pump	Use a brush and compressed air	Once a year or for prolonged inactivity
Check that the overflow valves are working correctly	Remove valves	Once a month
Lubricate the power take-off (versions M - MA - K - KA and D)	Oil the P.T.O. with a brush and lubricating oil	Once a month
Wash and clean the valves	Remove valves	Once a month

12 - PUTTING OUT OF SERVICE AND DEMOLITION

Before demolishing the Rotary blades vacuum pump the following materials should be separated:

- lubricating oil;
- parts in rubber and plastic;
- parts in cast iron and steel;

and disposed of correctly.

Do not discard the Rotary blades vacuum pump in the environment.

For disposal of the lubricating oil make use of specialised treatment services.