

GRAMMER
 Ersatzteilzeichnung
 SPARE PARTS DRAWING
 MSG85-02

 Sammelzeichnung
 COLLECTIVE DRAWING
 Zutreffende Positionen
 siehe Ersatzteilliste!
 CORRESPONDING POSITIONS
 SEE SPARE PARTS LIST!
 Stand/LEVEL: 03.12.2019
 REV. 2.0.0

Schnittkante:
 Zeichnung vor
 Weitergabe beschneiden
 LINE FOR CUTTING:
 CUT HERE BEFORE TRANSFER THE DRAWING

REV. 1.0.0

Urspruengliche Aufschaubpositionen muessen bei Montage eingehalten werden
 ORIGINAL MOUNTING POSITIONS HAVE TO BE KEPT FOR ASSEMBLY
 Komplet-Pos. beinhalten die jeweils in Klammer () aufgefuehrte Position
 MAIN POSITIONS COMPRISE THE POSITIONS INDICATED IN BRACKETS ()

Positionen in [] spiegelbildliche Ausfuehrung
 POSITIONS IN [] LATERALLY REVERSED VERSION

Folgende entfallenen Positionen nicht wieder belegen:
 DO NOT OCCUPY THE FOLLOWING OMITTED POSITIONS: ... **27, 28**

CC Kritisches Merkmal Sicherheitsrelevanz: Festlegung durch gesetzliche Vorschrift, Kunde oder interner Risikobewertung CRITICAL CHARACTERISTICS SAFETY: DEFINITION BY LEGAL REQUIREMENTS, CUSTOMER OR INTERNAL RISK EVALUATION																																							
SC Signifikantes Merkmal (Passung oder Funktion): Festlegung durch Kunde oder interner Risikobewertung SIGNIFICANT CHARACTERISTICS (FORM OR FUNCTION): DEFINITION BY CUSTOMER OR INTERNAL RISK EVALUATION																																							
Massgebend ist der deutsche Text / ONLY THE GERMAN LANGUAGE VERSION OF THIS TEXT SHALL BE BINDING																																							
<table border="1"> <tr> <td>h</td> <td>Uebnahme/TAKE OVER</td> <td>CAIG25101179</td> <td>29.11.19</td> <td>MOR</td> <td>LOB</td> <td>03.12.19</td> <td colspan="3"></td> </tr> <tr> <td>INDEX 2D</td> <td>Feld SEC.</td> <td>Änderungsbeschreibung REVISIONS DESCRIPTION</td> <td>Änderungsnummer REVISIONS NO.</td> <td>Datum DATE</td> <td>Bearbeiter/EDITOR</td> <td>geprüft/CHECK</td> <td>Datum DATE</td> <td colspan="2"></td> </tr> <tr> <td colspan="7">Spezifikationen / SPECIFICATIONS</td> <td colspan="3">Freier Text / FREE TEXT</td> </tr> </table>										h	Uebnahme/TAKE OVER	CAIG25101179	29.11.19	MOR	LOB	03.12.19				INDEX 2D	Feld SEC.	Änderungsbeschreibung REVISIONS DESCRIPTION	Änderungsnummer REVISIONS NO.	Datum DATE	Bearbeiter/EDITOR	geprüft/CHECK	Datum DATE			Spezifikationen / SPECIFICATIONS							Freier Text / FREE TEXT		
h	Uebnahme/TAKE OVER	CAIG25101179	29.11.19	MOR	LOB	03.12.19																																	
INDEX 2D	Feld SEC.	Änderungsbeschreibung REVISIONS DESCRIPTION	Änderungsnummer REVISIONS NO.	Datum DATE	Bearbeiter/EDITOR	geprüft/CHECK	Datum DATE																																
Spezifikationen / SPECIFICATIONS							Freier Text / FREE TEXT																																
letzte Pos./LAST POS.: 72																																							
D-Kennz./D-SIGN		Freiastoleranz / DIMENSIONAL VARIATION		Werkstoff / MATERIAL		Massstab / SCALE		Z.Art./DWG. TYPE																															
Fußende Masse nach 3D-Modell / MISSING DIMENSIONS LINE 3D-MODEL		INDEX		/		/		EZ																															
Modell Nr. / MODEL NO.		INDEX		/		/		Volumen / VOLUME																															
Modell PSM REVISION (nach Freigabe Inter / NO RELEASE INTER)		Zeichnungsnummer		Massnorme / DIMENSION STANDARD		Gewichte / WEIGHT		Og																															
Kunde / Lieferant		Zeichnungsnummer		/		gerechnet / CALCL.		g																															
Kunde / Lieferant		Zeichnungsnummer		/		gemessen / MEASURED																																	
CUSTOMER / SUPPLIER		DRAWING NUMBER		Benennung / DESCRIPTION		ISO 5456-2																																	
Datum / DATE		Name / NAME		ERSATZTEILZEICHNUNG F.FEDERUNG KPL.		erstellt / CREATED		01																															
Gez. / DRAWN		29.11.19		MOR		CATIA		01																															
gepr. / CHECK		03.12.19		LOB		V5R28SP3		01																															
Norm / STANDARD		02.12.19		KA		Blatt / SHEET		A1																															
TF / FQ						Format / FORMAT		A1																															
Schwermetallverbot nach Ely EU Richtlinie 2002/95/EG (RoHS) oder nach Ely EU Richtlinie 2002/95/EG (RoHS)		Z.-Nr. / DWG. NO.		MSG85-02		von/Gf. 01																																	
Ursprung / SOURCE		abgebl. von / LIKE		MSG85-00 Ersatz fuer / REPLACEMENT FOR		06.2017 Rev.10.6																																	

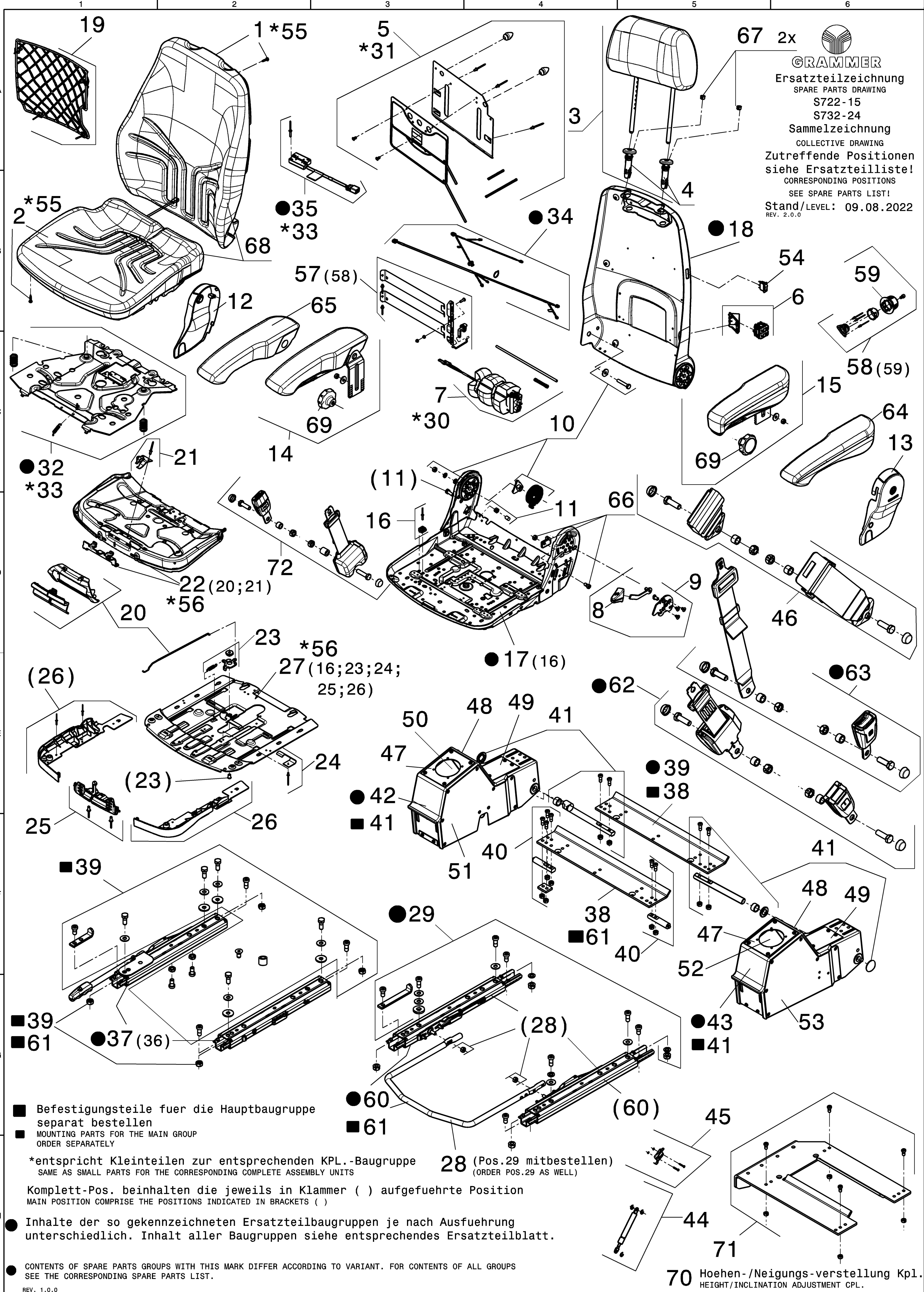

GRAMMER
 Ersatzteilzeichnung
 SPARE PARTS DRAWING
 S722-15
 S732-24
 Sammelzeichnung
 COLLECTIVE DRAWING
 Zutreffende Positionen
 siehe Ersatzteilliste!
 CORRESPONDING POSITIONS
 SEE SPARE PARTS LIST!
 Stand/LEVEL: 09.08.2022
 REV. 2.0.0

Schnittkante:
 Zeichnung vor
 Weitergabe beschneiden
 LINE FOR CUTTING:
 CUT HERE BEFORE TRANSFER THE DRAWING

REV. 1.0.0

- Befestigungsteile fuer die Hauptbaugruppe separat bestellen
MOUNTING PARTS FOR THE MAIN GROUP ORDER SEPARATELY
- *entspricht Kleinteilen zur entsprechenden KPL.-Baugruppe
SAME AS SMALL PARTS FOR THE CORRESPONDING COMPLETE ASSEMBLY UNITS
- Inhalte der so gekennzeichneten Ersatzteilbaugruppen je nach Ausfuehrung unterschiedlich. Inhalt aller Baugruppen siehe entsprechendes Ersatzteilblatt.
- CONTENTS OF SPARE PARTS GROUPS WITH THIS MARK DIFFER ACCORDING TO VARIANT. FOR CONTENTS OF ALL GROUPS SEE THE CORRESPONDING SPARE PARTS LIST.

28 (Pos.29 mitbestellen)
 (ORDER POS.29 AS WELL)

70 Hoehen-/Neigungs-verstellung Kpl.
 HEIGHT/INCLINATION ADJUSTMENT CPL.

CC	Kritisches Merkmal Sicherheitsrelevanz: Festlegung durch gesetzliche Vorschrift, Kunde oder interner Risikobewertung CRITICAL CHARACTERISTICS SAFETY: DEFINITION BY LEGAL REQUIREMENTS, CUSTOMER OR INTERNAL RISK EVALUATION																																				
SC	Signifikantes Merkmal (Passung oder Funktion): Festlegung durch Kunde oder interner Risikobewertung SIGNIFICANT CHARACTERISTICS (FORM OR FUNCTION): DEFINITION BY CUSTOMER OR INTERNAL RISK EVALUATION																																				
Massgebend ist der deutsche Text / ONLY THE GERMAN LANGUAGE VERSION OF THIS TEXT SHALL BE BINDING																																					
<table border="1"> <thead> <tr> <th>INDEX</th> <th>2D</th> <th>3D</th> <th>SEC.</th> <th>Änderungsbeschreibung REVISIONS DESCRIPTION</th> <th>Änderungsnummer REVISIONS NO.</th> <th>Datum DATE</th> <th>Bearbeiter/ EDITOR</th> <th>geprüft/ CHECK</th> <th>Datum DATE</th> </tr> </thead> <tbody> <tr> <td>s</td> <td></td> <td></td> <td></td> <td>Pos.72 hinzu/ADDED</td> <td>VALG25100554</td> <td>09.08.22</td> <td>KADA</td> <td>MS</td> <td>09.08.22</td> </tr> <tr> <td>r</td> <td></td> <td></td> <td></td> <td>Übernahme/TAKEOVER, Pos.71 hinzu/ADDED</td> <td>CAKG25101214</td> <td>11.01.22</td> <td>WIT</td> <td>WIT</td> <td>11.01.22</td> </tr> </tbody> </table>								INDEX	2D	3D	SEC.	Änderungsbeschreibung REVISIONS DESCRIPTION	Änderungsnummer REVISIONS NO.	Datum DATE	Bearbeiter/ EDITOR	geprüft/ CHECK	Datum DATE	s				Pos.72 hinzu/ADDED	VALG25100554	09.08.22	KADA	MS	09.08.22	r				Übernahme/TAKEOVER, Pos.71 hinzu/ADDED	CAKG25101214	11.01.22	WIT	WIT	11.01.22
INDEX	2D	3D	SEC.	Änderungsbeschreibung REVISIONS DESCRIPTION	Änderungsnummer REVISIONS NO.	Datum DATE	Bearbeiter/ EDITOR	geprüft/ CHECK	Datum DATE																												
s				Pos.72 hinzu/ADDED	VALG25100554	09.08.22	KADA	MS	09.08.22																												
r				Übernahme/TAKEOVER, Pos.71 hinzu/ADDED	CAKG25101214	11.01.22	WIT	WIT	11.01.22																												
Spezifikationen / SPECIFICATIONS																																					
Freier Text / FREE TEXT																																					
letzte Pos./LAST POS.: 72																																					
D-Kennz./D-SIGN		Freiemaßtoleranz / DIMENSIONAL VARIATION		Werkstoff / MATERIAL		Maßstab / SCALE		Z.Art./DWG. TYPE																													
Fußende Masse nach 3D-Modell / MISSING DIMENSIONS LINE 3D-MODEL		INDEX		/		/		EZ																													
Modell-Nr.		INDEX		/		/		Volumen / VOLUME																													
Modell-Nr.		INDEX		/		/		Gewichte / WEIGHT																													
Modell-Nr.		INDEX		/		/		geschneidet / CALCL. (
Modell-Nr.		INDEX		/		/		genossen / WEIGHTED																													
Kunde / Lieferant		Zeichnungsnummer		Bemerkung / DESCRIPTION		Z.-Nr. / DWG. NO.		von/Gf. 01																													
Gez. / DRAWN		Datum / DATE		Name / NAME		ERSATZTEILZEICHNUNG F. OBERTEIL KPL.		erstellt / CREATED																													
Gepr. / CHECK		Datum / DATE		Name / NAME		SPARE PART DRAWING F. UPPER P. CPL.		CATIA																													
Norm. / STANDARD		Datum / DATE		Name / NAME		S722-15		V5R28SP3																													
TF / FQ		Datum / DATE		Name / NAME		S722-15		Blatt / SHEET																													
Ursprung / SOURCE		abgegl. von / LINE		Sicherheitsüberholt nach ELY EU Richtlinie 2000/53/EG RISK OF METAL ACCORDING TO ELY EU DIRECTIVE 2000/53/EG		S722-15 Ersatz fuer / REPLACEMENT FOR		Format / FORMAT																													
Ursprung / SOURCE		abgegl. von / LINE		Sicherheitsüberholt nach ELY EU Richtlinie 2000/53/EG RISK OF METAL ACCORDING TO ELY EU DIRECTIVE 2000/53/EG		S722-15 Ersatz fuer / REPLACEMENT FOR		A1																													
Ursprung / SOURCE		abgegl. von / LINE		Sicherheitsüberholt nach ELY EU Richtlinie 2000/53/EG RISK OF METAL ACCORDING TO ELY EU DIRECTIVE 2000/53/EG		S722-15 Ersatz fuer / REPLACEMENT FOR		06.2017 Rev.10.0																													

