

# SERVICE - INFO



**LuK Nr: 333 0170 11 – 330mm TDCA 28 x 32 x 17**

**Bulletin 988 1000 710**

**STEYR – M9078, M9083, M9086, M9094, [Sisu / MWM]** 

**CASE – CS78, CS86, CS94 [Sisu / MWM]** 

<b>Info:</b>	<b>333 0170 11 replaces / ersetzt / remplace / sustituye a / sostituisce 333 0136 10 / 333 0170 10</b>
<b>(GB)</b>	Re-machine the flywheel inner recess to a diameter of $185 \pm 0.5$ mm and a depth of 8 mm to avoid rivet contacting flywheel.
<b>(D)</b>	Um zu verhindern, dass die Nieten mit dem Schwungrad in Berührung kommen, muss die innere Vertiefung des Schwungrades auf einen Durchmesser von $185 \pm 0.5$ mm und eine Tiefe von 8 mm nachgearbeitet werden.
<b>(F)</b>	Ré-usinez la cavité intérieure du volant-moteur de sorte à obtenir un diamètre de $185 \pm 0.5$ mm et une profondeur de 8 mm pour éviter que le rivet ne touche le volant-moteur.
<b>(E)</b>	Rectifique el hueco interior del volante-motor con un diámetro de $185 \pm 0.5$ mm y una profundidad de 8 mm, con el fin de evitar que entre en contacto con los remaches.
<b>(I)</b>	Rettificare nuovamente la cavità interna del volano a un diametro di $185 \pm 0.5$ mm e una profondità di 8 mm per evitare che il rivetto entri in contatto con il volano.
<b>LuK Repset:</b>	633 3008 09 = 233 0034 10 [331 0228 10] + <b>333 0170 11</b>

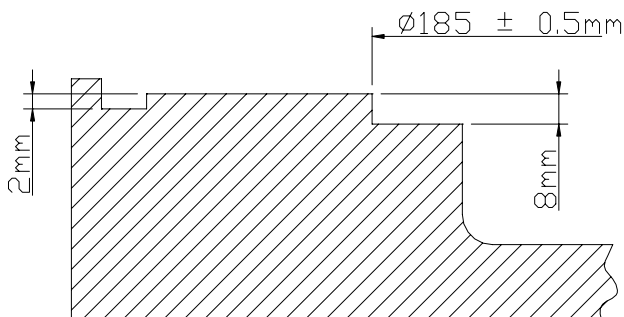

Flywheel  
Schwungrad  
Volant-moteur  
Volante-motor  
Volano



Issue Level 3

**LuK Aftermarket Service UK Ltd.**  
Holme Lacy Road, Rotherwas  
HR2 6LA Hereford · The United Kingdom  
Phone: +44 1432 264264 · Fax +44 1432 275146  
e-mail: LuK-AS.uk.pm@schaeffler.com  
**A Member of the Schaeffler Group**

