

**ERSATZTEIL-LISTE
SPARE PARTS LIST
LISTE DES PIECES DE
RECHANGE**

Änderungen vorbehalten!
With the reserve of modifications!
Modifications reserves!

T-3550

ZF- SCHLEPPERTRIEBWERK
ZF-TRACTOR TRANSMISSION
ENSEMBLE BOITE-PONT ZF
POUR TRACTEURS AGRICOLES

Stückliste Nr.: / Parts list No.: / Liste de pieces No.: 2071 060 015/ 017/ 018/ 019/ 020



ZF Passau GmbH
Donaustr. 25 - 71
D- 94 034 Passau

Ausgabe: 04.84

LIEFERBEDINGUNGEN FÜR ERSATZTEILE

Bestellungen von Ersatzteilen sollen stets folgende Angaben enthalten, um eine richtige und schnelle Lieferung zu sichern:

1. **Type**
2. **Aggregatnummer**
3. **Stücklistennummer**
4. **Fabrikat und Type des Fahrzeuges**
5. **Benennung des Ersatzteils:** Wie in der Ersatzteilliste aufgeführt.
6. **Ersatzteil-Nummer:** Siehe Ersatzteilliste, Nummer ist größtenteils auch im Teil eingeschlagen.
7. **Versandart:** Post, Luftpost, Express, Fracht, Eilgut, Stückgut; fehlen Angaben, so geschieht der Versand nach unserem Ermessen.

} Angaben siehe Typenschild
bzw. eingeschlagene Zahlen

Telefonische oder telegraphische Bestellungen bitten wir schriftlich zu bestätigen.

Der Versand geschieht auf Gefahr des Käufers, auch dann, wenn die Ersatzteile nicht berechnet werden.

Zahlungsbedingungen: Die Kosten für Ersatzteile werden durch Nachnahme erhoben.

DELIVERY CONDITIONS FOR SPARE PARTS

In order to secure a correct and prompt delivery, all spare part orders should be compiled as follows:

1. **Type**
2. **Serial-No.**
3. **Parts list No.**
4. **Trade mark and type of vehicle:**
5. **Denomination of spare part:** according to the indication in the parts list.
6. **Spare parts No.:** see spare parts list, the number is very often engraved on the part.
7. **Way of delivery:** mail, air mail, express delivery, ordinary freight, express goods, cargo; if no indication is made, the transportation will be realized to our opinion.

} see indications on type
identification plate
resp. engraved part number

We kindly ask you to confirm orders given by telephone call or telegramme.

Even if the spare parts are free of charge the delivery will be to the buyers obligations.

Terms : Cash on delivery

CONDITIONS DE LIVRAISON POUR LES PIÈCES DE RECHANGE

Afin de vous assurer une prompte et correcte livraison, les commandes des pièces de rechange doivent être rédigées dans la façon suivante:

1. **Type**
2. **No. de la série**
3. **No. de la liste de pièces**
4. **Marque et type de véhicule**
5. **Dénomination de la pièce de rechange** come indiqué sur la liste des pièces de rechange.
6. **No. de la pièce :** v. liste des pièces de rechange, la plupart du temps, le nombre vient aussi poinçonné sur la pièce.
7. **Mode d'expédition :** ar poste, poste aérienne, express, en grande vitesse, en colis; où il n'y a pas des spécifications, l'expédition sera effectuée à notre choix.

} v. les indications sur la plaque
de type, resp. les chiffres poinçonnées

Nous vous prions de nous confirmer par écrit les commandes données par téléphone ou télégramme.

La marchandise sera toujours expédiée aux risques de l'acheteur, même dans le cas où les de rechange ne viennent pas facturées.

Conditions de payment: contre remboursement.

Wichtige Hinweise/Bedienung und Wartung/Schmiervorschrift enthalten in Werkstatthandbuch für ZF - Schleppertriebwerke der Baureihe T - 3000 mit ZF - Regelkraftheber

Ausgabe: 1980

Sowie in:

Bedienungsanleitung für ZF - Schleppertriebwerke der Baureihe T - 3000 mit ZF - Regelkraftheber.

Important notes/operation and maintenance/lubrication chart included in the Workshop manual for ZF - Tractor transmission series T - 3000 with ZF - controlled power lift.

edition: 1980

As well as in:

Instructions for the operation of ZF - tractor transmission - series T - 3000 with ZF - controlled power lift.

Instructions importantes/l' opération et l' entretien/instructions pour la lubrification sont incluses dans le Manuel pour les ensembles boîte - pont ZF pour tracteurs agricoles de la série T - 3000 avec dispositif de relevage ZF à régulation.

édition: 1980

Ains que dans:

le Manuel pour l' opération et l' entretien des ensembles boîte - pont ZF - pour tracteurs agricoles de la série T - 3000 avec dispositif de relevage ZF à régulation.

Tafel/Table/Planche 1 T - 3550 Fendt

Getriebegehäuse
 Ölversorgung
 Gehäusedeckel vorne
 Schaltung
 Pumpenantrieb - Verschlusssteile
 Kriechgang - Verschlusssteile
 Eingangswelle

Gearbox housing
 Oil supply
 Housing cover, front
 Gearshift assembly
 Pump drive assembly - Locking components
 Locking components of the creep speed range
 Primary shaft

Carter de la boîte
 Distribution d'huile
 Couvercle du carter AV
 Commande du passage des vitesses
 Entraînement de la pompe - pièces de fermeture
 Vitesse lente - pièces de fermeture
 Arbre primaire

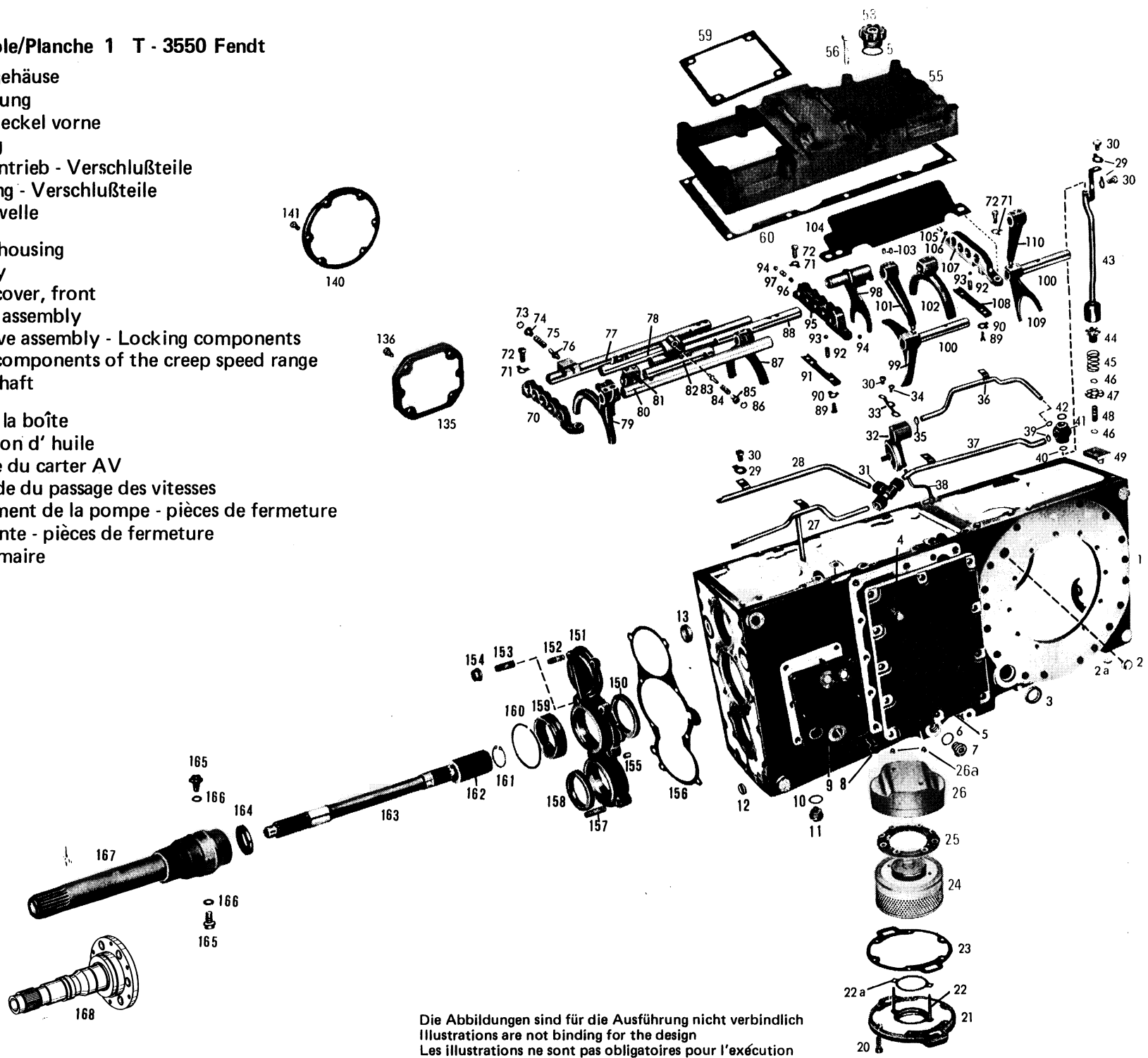

Die Abbildungen sind für die Ausführung nicht verbindlich
 Illustrations are not binding for the design
 Les illustrations ne sont pas obligatoires pour l'exécution

Bild Nr. Fig. No. Fig. No.	Teilnummer Partnumber No. de pièce	Benennung	Description	Désignation	0 1 5	0 1 7	0 1 8	0 1 9	0 2 0									
1	2052 301 037	Getriebegehäuse	Gearbox housing	Carter de la boîte	1	1	1	—	—									
—	2052 301 043	Getriebegehäuse	Gearbox housing	Carter de la boîte	—	—	—	1	1									
—	0730 365 069	Baumusterschild	Type identification plate	Plaque de type	1	1	1	1	1									
—	0631 311 009 3x5 DIN 1476	Kerbnagel	Grooved pin	Clou cannelé	4	4	4	4	4									
2	0630 361 033 20 DIN 443	Verschlußdeckel	Sealing cover	Couvercle de fermeture	1	1	1	1	1									
2a	0630 361 038 12 DIN 443	Verschlußdeckel	Sealing cover	Couvercle de fermeture	2	2	2	2	2									
3	0634 300 355 B 30x40x7 ZFN - 132	Wellendichtring	Shaft seal	Bague d'étanchéité	2	2	2	2	2									
4	0636 016 009 M 12 x 25 DIN 933 - 8.8	Sechskantschraube	Hex. head screw	Vis à six pans	11	11	11	11	11									
5	2052 346 001	Verschlußdeckel	Sealing cover	Couvercle de fermeture	1	1	1	1	1									
6	0634 801 227 A 33x39 DIN 7603	Dichtring	Seal ring	Rondelle d'étanchéité	2	2	2	2	2									
7	0636 302 009 M 33 x 2 DIN 908 - 6.8	Verschlußschraube	Screw plug	Bouchon fileté	2	2	2	2	2									
8	0636 015 127 M 10 x 30 DIN 933 - 8.8	Sechskantschraube	Hex. head screw	Vis à six pans	4	4	4	4	4									
—	0636 015 114 M 10 x 22 DIN 933 - 8.8	Sechskantschraube	Hex. head screw	Vis à six pans	2	2	2	2	2									
9	2052 342 068	Deckel	Cover	Couvercle	1	—	—	1	1									
—	2052 342 069	Deckel	Cover	Couvercle	—	1	1	—	—									
10	0634 801 200 A 24x29 DIN 7603	Dichtring	Seal ring	Rondelle d'étanchéité	1	1	1	1	1									
11	0015 300 160	Verschlußschraube	Screw plug	Bouchon fileté	1	1	1	1	1									
12	0630 361 033 20 DIN 443	Verschlußdeckel	Sealing cover	Couvercle de fermeture	1	1	1	1	1									

Tafel 1 T - 3550 Fendt Table Planche					Stückzahl nach Ausführung Quantity per model Nombre par modèle															
Bild Nr. Fig. No. Fig. No.	Teilnummer Partnumber No. de pièce	Benennung	Description	Désignation	0	0	0	0	0											
					1	1	1	1	2											
13	0630 361 046 42 DIN 443	Verschlußdeckel	Sealing cover	Couvercle de fermeture	2	2	2	2	2											
		Ölversorgung	Oil supply	Distribution d'huile																
20	0636 015 120 M 10 x 25 DIN 933 - 8.8	Sechskantschraube	Hex. head screw	Vis à six pans	6	6	6	6	6											
21	2052 336 154	Deckel	Cover	Couvercle	1	1	1	1	1											
22	0636 610 215 M 5 x 110 DIN 939 - 8.8	Stiftschraube	Set screw	Vis sans tête	2	2	2	2	2											
22a	0501 303 920	Dichtring	Seal ring	Rondelle d'étanchéité	1	1	1	1	1											
23	2052 336 067	Dichtung	Gasket	Garniture	1	1	1	1	1											
24	0501 203 134	Filtereinsatz kompl. (mit Bild - Nr. 22a)	Filter element ass. (with Fig. - No. 22a)	Cart filtrante compl. (avec Fig. - no. 22a)	1	1	1	1	1											
25	0501 203 135	Magnetsystem	Magnetic system	System magnetique	1	1	1	1	1											
26	2052 236 093	Saugglocke kompl.	Suction cap ass.	Cloche succion compl.	1	1	1	1	1											
26a	0637 011 547 M 5	Sicherungsmutter	Locking nut	Contre - écrou	2	2	2	2	2											
27	2052 236 068	Rohr I kompl.	Lupricating pipe I ass.	Tube I compl.	1	1	1	1	1											
28	2052 236 090	Rohr II kompl.	Lupricating pipe II ass.	Tube II compl.	1	1	1	1	1											
29	0630 601 006 10,5 DIN 93	Sicherungsblech	Lock plate	Frein d'écrou	5	5	5	5	5											
30	0636 015 270 M 10 x 16 DIN 933 - 8.8	Sechskantschraube	Hex. head screw	Vis à six pans	7	7	7	7	7											
31	0637 880 050 QL 12 DIN 2353	Verschraubung	Bolting	Raccord visse	1	1	1	1	1											
32	2052 336 147	Anschlußstück	Adapter	Raccord	1	1	1	1	1											
33	2052 336 149	Sicherungsblech	Lock plate	Frein d'écrou	1	1	1	1	1											
34	0736 010114	Schraube	Screw	Vis	1	1	1	1	1											
35	0634 306 011 12,3x2,4 ZFN- 744	Runddichtring	Annular seal ring	Joint annulaire	1	1	1	1	1											
36	2052 236 092	Rohr IV kompl.	Lupricating pipe IV ass.	Tube IV compl.	1	1	1	1	1											

Bild Nr. Fig. No. Fig. No.	Teilnummer Partnumber No. de pièce	Benennung	Description	Désignation	0	0	0	0	0											
					1	1	1	1	2											
					5	7	8	9	0											
37	2052 236 047	Rohr III kompl.	Lupricating pipe III ass.	Tube III compl.	1	1	1	1	1											
38	2052 236 088	Ölzuführung kompl.	Oil supply ass.	Conduite d' huile compl.	1	1	1	1	1											
39	0634 306 011 12,3x2,4 ZFN- 744	Runddichtring	Annular seal ring	Joint annulaire	2	2	2	2	2											
40	0634 306 015 15,3x2,4 ZFN- 744	Runddichtring	Annular seal ring	Joint annulaire	1	1	1	1	1											
41	2052 336 108	Verteilerstück	Oil distributor	Distributeur	1	1	1	1	1											
42	0634 306 022 22,3x2,4 ZFN- 744	Runddichtring	Annular seal ring	Joint annulaire	1	1	1	1	1											
43	2052 236 083	Standrohr kompl.	Vertical pipe ass.	Ensemble tube vertical	1	1	1	1	1											
44	2052 336 130	Ventilscheibe	Valve plate	Anneau de soupape	1	1	1	1	1											
45	1210 307 032	Druckfeder	Detent spring	Ressort de compression	1	1	1	1	1											
46	0630 501 007 11x1 DIN 471	Sicherungsring	Circlip	Circlip	2	2	2	2	2											
47	2052 336 128	Ventildeckel	Valve cover	Couvercle de soupape	1	1	1	1	1											
48	2052 336 129	Führungsbolzen	Guide pin	Boulon de guidage	1	1	1	1	1											
49	2052 236 084	Halteblech	Retaining plate	Bague - carniéré	1	1	1	1	1											
		Gehäusedeckel vorne	Housing cover, front	Couvercle du carter AV																
55	0501 308 882	Gehäusedeckel **	Housing cover **	Couvercle du carter **	1	1	1	1	1											
56	0636 010188 M 10 x 85 DIN 931 - 8.8	Sechskantschraube	Hex. head screw	Vis à six pans	8	8	8	8	8											
—	0636 101 163 M 10 x 80 DIN 912 - 8.8	Zylinderschraube (zu Bild 55)	Socket head screw (ref. Figure 55)	Vis à tête cylindrique (ref. Figure 55)	2	2	2	2	2											
57	0634 801 215 A 42x49 DIN 7603	Dichtring	Seal ring	Rondelle d' étanchéité	1	1	1	1	1											
58	2052 206 007	Entlüfter kompl.	Breather ass.	Ensemble reniflard	1	1	1	1	1											
59	2052 306 284	Dichtung	Gasket	Garniture	1	1	1	1	1											
—	0636 015 127 M 10 x 30 DIN 933 - 8.8	Sechskantschraube	Hex. head screw	Vis à six pans	4	4	4	4	4											
60	2052 306 285	Dichtung	Gasket	Garniture	1	1	1	1	1											

Bild Nr. Fig. No. Fig. No.	Teilnummer Partnumber No. de pièce	Benennung	Description	Désignation	0	0	0	0	0												
					1	1	1	1	2												
					5	7	8	9	0												
		Schaltung	Gearshift assembly	Commande du passage des vitesses																	
70	2052 306 042	Lagerbügel (vorne)	Bearing cap (front)	Support (AV)	1	1	1	1	1												
71	0630 603 007 10,5 DIN 463	Sicherungsblech	Lock plate	Frein d'écrou	6	6	6	6	6												
72	0636 015 120 M 10 x 25 DIN 933 - 8.8	Sechskantschraube	Hex. head screw	Vis à six pans	6	6	6	6	6												
73	0630 502 003 15x1 DIN 472	Sicherungsring	Circlip	Circlip	1	1	1	1	1												
74	2052 306 214	Führungshülse	Guide sleeve	Douille de guidage	1	1	1	1	1												
75	0732 040 439	Druckfeder	Detent spring	Ressort de compression	1	1	1	1	1												
76	2052 306 054	Anschlagbolzen	Detent plug	Boulon de butée	1	1	1	1	1												
77	2052 206 242	Schaltschiene kompl. (1. und 2. Gang)	Shifter rod ass. (1st and 2nd speed)	Ensemble tige de commande (1ère et 2ème vitesse)	1	1	1	1	1												
78	2052 206 257	Schaltschiene kompl. (3. und 4. Gang)	Shifter rod ass. (3rd and 4th speed)	Ensemble tige de commande (3ème et 4ème vitesse)	1	1	1	1	1												
79	2052 306 298	Schaltgabel (Normal- und Zwischengruppe)	Shifter fork (normal and splitter range)	Fourchette de commande (Groupe normal et intermédiaire)	1	1	1	1	1												
80	2052 306 323	Schaltschiene (Normal- und Zwischengruppe)	Shifter rod (normal and splitter range)	Tige de commande (Groupe normal et intermédiaire)	1	1	1	1	1												
81	2052 306 300	Mitnehmer	Drive ring	Entraîneur	1	1	1	1	1												
82	2052 306 304	Schaltschiene (Rückwärtsgruppe)	Shifter rod (Reverse speed range)	Tige de commande (Groupe marche AR)	1	1	1	1	1												
-	0630 000 120	Paßscheibe 22x30x1,0 DIN 988	Shim	Rondelle d'ajustage	1	1	1	1	1												
-	0630 000 165	wahlweise: 22x30x1,5 DIN 988	optional:	en option:	1	1	1	1	1												
-	0630 100 002	22x30x2,0 DIN 988			1	1	1	1	1												
-	0630 000 122	22x30x0,2 DIN 988			1	1	1	1	1												
-	0630 000 121	22x30x0,5 DIN 988			1	1	1	1	1												
-	0630 000 168	22x30x1,2 DIN 988			1	1	1	1	1												
-	0630 000 166	22x30x1,4 DIN 988			1	1	1	1	1												
83	2052 306 054	Anschlagbolzen	Detent plug	Boulon de butée	1	1	1	1	1												
84	0732 040 439	Druckfeder	Detent spring	Ressort de compression	1	1	1	1	1												
85	2052 306 214	Führungshülse	Guide sleeve	Douille de guidage	1	1	1	1	1												

6 *nur komplett lieferbar*/only available as a complete unit/*a livrer seulement en ensemble/**nur von Fahrzeugfirma lieferbar/**to be delivered only by the manufacturer of the vehicle/**a livrer seulement par le constructeur du véhicule
 sets Aggregat Nr., Stücklisten - Nr. und Type angeben ! please indicate serial - No., parts list - No. and type ! Indiquez toujours sur vos commandes No. de la serie, No. de la liste de pieces et le type !

Bild Nr. Fig. No. Fig. No.	Teilnummer Partnumber No. de pièce	Benennung	Description	Désignation	0	0	0	0	0											
					1	1	1	1	2											
					5	7	8	9	0											
86	0630 502 003 15x1 DIN 472	Sicherungsring	Circlip	Circlip	1	1	1	1	1											
87	2052 306 299	Schaltgabel (Rückwärtsgruppe)	Shifter fork (Reverse speed range)	Fourchette de commande (Groupe marche AR)	1	1	1	1	1											
88	2052 206 239	Schaltchiene kompl. (5. und 6. Gang)	Shifter rod ass. (5th and 6th speed)	Ensemble tige de commande (5ème et 6ème vitesse)	1	1	1	1	1											
89	0636 015 073 M 8 x 18 DIN 933 - 8.8	Sechskantschraube	Hex. head screw	Vis à six pans	3	3	3	3	3											
-	0636 015 060 M 8 x 12 DIN 933 - 8.8	Sechskantschraube	Hex. head screw	Vis à six pans	1	1	1	1	1											
90	0630 603 005 8,4 DIN 463	Sicherungsblech	Lock plate	Frein d'écrou	4	4	4	4	4											
91	2052 306 302	Deckblech	Retainer plate	Tôle	1	1	1	1	1											
92	1203 306 092	Druckfeder	Detent spring	Ressort de compression	6	6	6	6	6											
93	0635 460 021 10 Ø DIN 5401	Kugel	Ball	Bille	6	6	6	6	6											
94	0635 460 015 8 Ø DIN 5401	Kugel	Ball	Bille	3	3	3	3	3											
95	2052 306 301	Lagerbügel (Mitte)	Bearing cap (centre)	Support (centre)	1	1	1	1	1											
96	0731 208 019	Sperrstift	Locking pin	Goujon d'arrêt	2	2	2	2	2											
97	0731 306 028	Sperrstift	Locking pin	Goujon d'arrêt	1	1	1	1	1											
-	0630 505 002 7 DIN 9045	Sprengring	Snap ring	Anneau de retenue	1	1	1	1	1											
98	2052 214 082	Schaltgabel (Kriechgang)	Shifter fork ass. (Creep speed range)	Ensemble fourchette (Vitesse lente)	1	1	1	1	1											
99	2052 306 359	Schaltgabel (3. und 4. Gang)	Shifter fork ass. (3rd and 4th speed)	Fourchette de commande (3ème et 4ème vitesse)	1	1	1	1	1											
100	2052 306 047	Lagerbolzen	King pin	Pivot de fusée	2	2	2	2	2											
101	2052 306 060	Umlenkhebel	Shift lever	Levier de renvoi	1	1	1	1	1											
102	2052 306 038	Schaltgabel (5. und 6. Gang)	Shifter fork (5th and 6th speed)	Fourchette de commande (5ème et 6ème vitesse)	1	1	1	1	1											
103	1238 306 065	Gewindestift	Set screw	Goupille fileté	10	10	10	10	10											
-	0731 611 019	Gewindestift	Set screw	Goupille fileté	2	2	2	2	2											

Tafel 1 T - 3550 Fendt Table Planche					Stückzahl nach Ausführung Quantity per model Nombre par modèle 2071 060														
Bild Nr. Fig. No. Fig. No.	Teilnummer Partnumber No. de pièce	Benennung	Description	Désignation	0 1 5	0 1 7	0 1 8	0 1 9	0 2 0										
		Kriechgang - Verschlußteile	Locking components of the creep speed range	Vitesse lente - Pièces de fermeture															
140	2052 314 001	Verschlußdeckel	Sealing cover	Couvercle de fermeture	1	1	1	1	1										
141	0636 015 114 M 10 x 22 DIN 933 - 8.8	Sechskantschraube	Hex. head screw	Vis à six pans	6	6	6	6	6										
		Eingangswelle	Primary shaft	Arbre primaire															
150	0734 319 064	Wellendichtring	Shaft seal	Bague d'étanchéité	1	1	1	1	1										
151	2052 310 158	Verschlußdeckel	Sealing cover	Couvercle de fermeture	1	1	1	1	1										
152	0636 610 216 M 8 x 22 DIN 939 - 10.9	Stiftschraube	Set screw	Vis sans tête	2	2	2	2	2										
153	0636 610 027 M 8 x 30 DIN 939 - 10.9	Stiftschraube	Set screw	Vis sans tête	4	4	4	4	4										
154	0637 011 528 M 8 - 8	Dichtmutter	Sealing nut	Ecrou d'étanchéité	8	8	8	8	8										
155	0631 306 071 10 M 6 x 16 ZFN - 6	Zylinderstift	Dowel	Goupille cylindrique	1	1	1	1	1										
156	2052 310 156	Dichtung	Gasket	Garniture	1	1	1	1	1										
157	0636 610 217 M 8 x 40 DIN 939 - 10.9	Stiftschraube	Set screw	Vis sans tête	2	2	2	2	2										
158	0734 309 052	Wellendichtring	Shaft seal	Bague d'étanchéité	1	1	1	1	1										
159	2052 310 144	Ring	Ring	Anneau	1	1	1	1	1										
160	0630 513 029 SW 110	Sprengring	Snap ring	Anneau de retenue	1	1	1	1	1										
161	0630 532 139 31x1,2 DIN 472	Sicherungsring	Circlip	Circlip	1	1	1	1	1										
162	2052 349 151	Profilbuchse	Profiled bush	Douille profilée	1	1	1	1	1										
163	2052 349 191	Eingangswelle	Primary shaft	Arbre primaire	1	1	1	1	1										
164	0734 300 109	Wellendichtring	Shaft seal	Bague d'étanchéité	1	1	1	1	1										

Bild Nr. Fig. No. Fig. No.	Teilnummer Partnumber No. de pièce	Benennung	Description	Désignation	0	0	0	0	0											
					1	1	1	1	2											
					5	7	8	9	0											
165	2052 349 181	Sicherungsschraube	Locking screw	Vis d'arrêt	2	2	2	2	2											
166	0634 313 035 8x2,5 ZFN- 744	Runddichtring	Annular seal ring	Joint annulaire	2	2	2	2	2											
167	2052 249 121	Hohlwelle kompl.	Quille shaft ass.	Ensemble arbre creux	1	1	1	1	1											
168	2052 349 203	Nabe	Hub	Moyeu	-	1	1	-	-											

10 *nur komplett lieferbar/*only available as a complete unit/*a livrer seulement en ensemble/**nur von Fahrzeugfirma lieferbar/**to be delivered only by the manufacturer of the vehicle/**a livrer seulement par le constructeur du vehicule
 stets Aggregat Nr. , Stücklisten - Nr. und Type angeben ! please indicate serial - No., parts list - No. and type ! indiquez toujours sur vos commandes No. de la serie, No. de la liste de pieces et le type !



Tafel/Table/Planche 2 T - 3550 Fendt Kriechgang, Creep speed range, Vitesse lente
 Pumpenantrieb, Pump drive assembly, Groupe moto - pompe

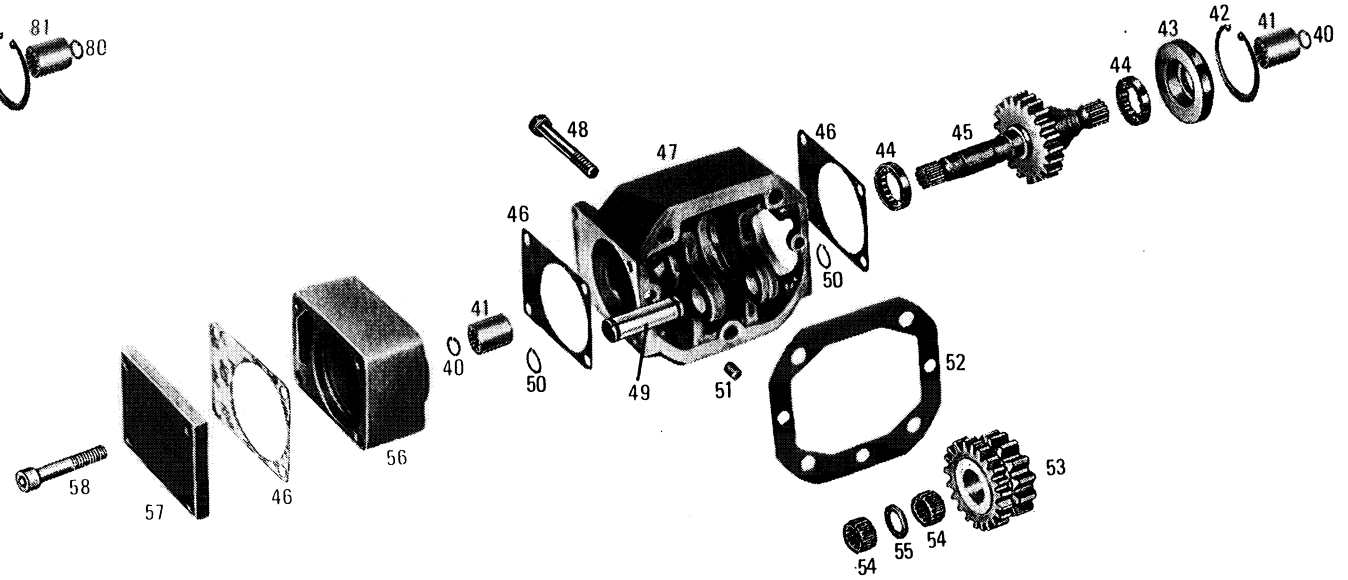
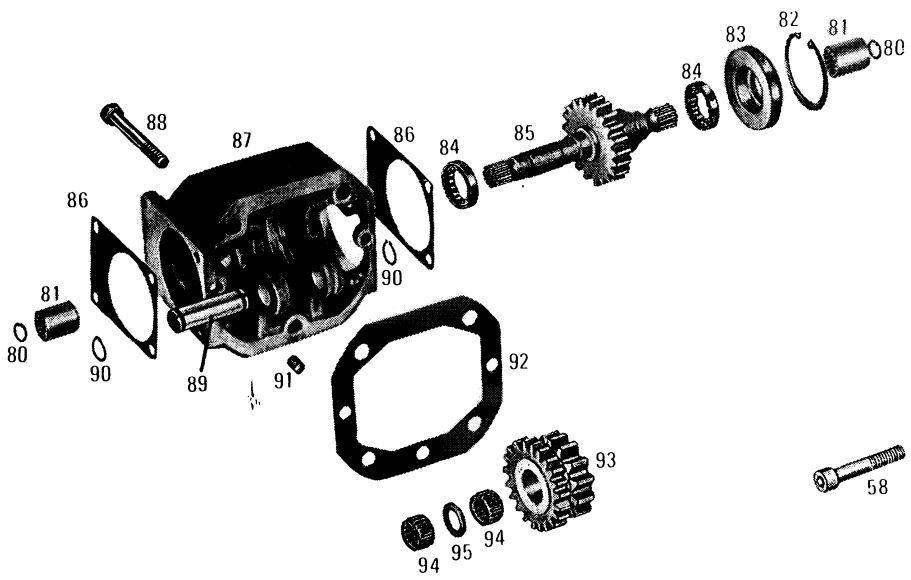
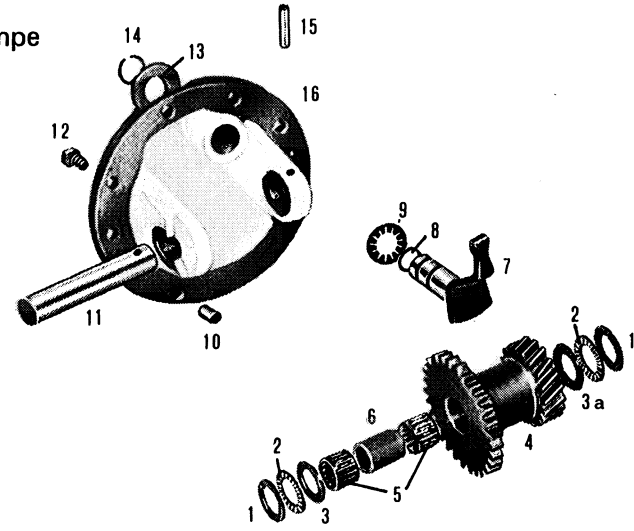
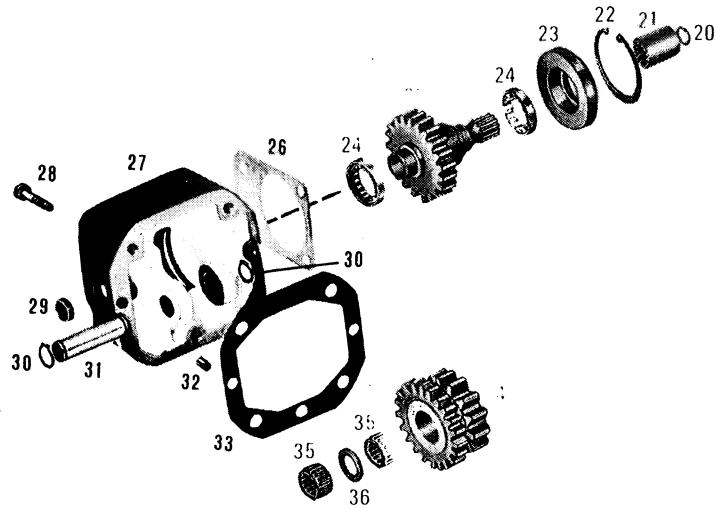

Die Abbildungen sind für die Ausführung nicht verbindlich
 Illustrations are not binding for the design
 Les illustrations ne sont pas obligatoires pour l'exécution

Bild Nr. Fig. No. Fig. No.	Teilnummer Partnumber No. de pièce	Benennung	Description	Designation	0	0	0	0	0												
					1	1	1	1	2												
					5	7	8	9	0												
1	0635 290 003 AS 2542 25x42x1	Kriechgang Axial Scheibe	Creep speed range Axial washer	Vitesse lente Rondelle de butée	2	2	2	2	2												
2	0635 302 011	Axial - Nadelkäfig	Axial needle cage	Cage à aiguilles	2	2	2	2	2												
3	0730 105 175	Scheibe 6,2 mm	Washer	Rondelle	1	1	1	1	1												
3a	0730 105 166	Scheibe 5,15 mm wahlweise:	Washer optional:	Rondelle en option:	1	1	1	1	1												
—	0730 105 167	5,2 mm			1	1	1	1	1												
—	0730 105 168	5,25 mm			1	1	1	1	1												
—	0730 105 169	5,35 mm			1	1	1	1	1												
—	0730 105 170	5,4 mm			1	1	1	1	1												
—	0730 105 171	5,5 mm			1	1	1	1	1												
—	0730 105 172	5,6 mm			1	1	1	1	1												
—	0730 105 173	5,8 mm			1	1	1	1	1												
4	2052 314 157	Doppelrad	Dual gear	Pignon double	1	1	1	1	1												
5	0750 115 061	Nadelkranz	Needle cage	Cage à aiguilles	2	2	2	2	2												
6	0730 062 582	Abstandsrohr	Spacer sleeve	Entretoise	1	1	1	1	1												
7	2052 214 060	Schalthebel kompl.	Control lever ass.	Levier de commande compl.	1	1	1	1	1												
8	0634 306 015 15,3x2,4 ZFN- 744	Runddichtring	Annular seal ring	Joint annulaire	1	1	1	1	1												
9	0632 051 016 36,6x20,4x0,4	Tellerfeder	Poppet spring	Ressort à disques	3	3	3	3	3												
10	0631 306 074 10 M 6x24 ZFN- 6	Zylinderstift	Dowel	Goujon cylindrique	2	2	2	2	2												
11	2052 314 136	Bolzen	Pin	Boulon	1	1	1	1	1												
12	0636 015 115 M 10 x 22 DIN 933 - 10.9	Sechskantschraube	Hex. head screw	Vis à six pans	6	6	6	6	6												
13	0730 150 185	Scheibe	Washer	Rondelle	1	1	1	1	1												
14	0630 513 090 SW 20	Sprengring	Snap ring	Anneau de retenue	1	1	1	1	1												
15	0631 329 074 6x50 DIN 1481	Spannstift	Roll pin	Goupille de serrage	1	1	1	1	1												
16	2052 314 127	Lagerdeckel	Bearing cover	Chapeau de palier	1	1	1	1	1												

Bild Nr. Fig. No. Fig. No.	Teilnummer Partnumber No. de pièce	Benennung	Description	Designation	0	0	0	0	0												
					1	1	1	1	2												
					5	7	8	9	0												
		Pumpenantrieb	Pump drive assembly	Groupe moto - pompe																	
20	0630 502 002 14x1 DIN 472	Sicherungsring	Circlip	Circlip	-	1	1	-	-												
21	2052 322 011	Mitnehmerbuchse	Drive ring	Douille d'entraînement	-	1	1	-	-												
22	0630 502 034 68x2,5 DIN 472	Sicherungsring	Circlip	Circlip	-	1	1	-	-												
23	2052 322 090	Buchse	Sleeve	Douille	-	1	1	-	-												
24	0735 450 030	Rollenlager	Roller bearing	Roulement à rouleaux	-	2	2	-	-												
25	2052 322 087	Antriebswelle	Drive shaft	Arbre de commande	-	1	1	-	-												
26	2032 322 007	Dichtung	Gasket	Garniture	-	1	1	-	-												
27	2052 322 014	Gehäuse	Housing	Carter	-	1	1	-	-												
28	0636 011 040 M 12 x 90 DIN 931 - 8.8	Sechskantschraube	Hex. head screw	Vis à six pans	-	3	3	-	-												
29	0630 361 039 32 DIN 443	Deckel	Cover	Couvercle	-	1	1	-	-												
30	0630 501 016 20x1,2 DIN 471	Sicherungsring	Circlip	Circlip	-	2	2	-	-												
31	2052 322 016	Lagerbolzen	King pin	Pivot de fusée	-	1	1	-	-												
32	0631 306 752 10 M 6x10 ZFN- 6	Zylinderstift	Dowel	Goujon cylindrique	-	2	2	-	-												
33	2052 322 033	Einstellscheibe	Shim	Rondelle de réglage	-	1	1	-	-												
34	2052 322 088	Doppelrad	Dual gear	Pignon double	-	1	-	-	-												
-	2052 322 092	Doppelrad	Dual gear	Pignon double	-	-	1	-	-												
35	0735 320 770	Nadelkranz	Needle cage	Cage à aiguilles	-	2	2	-	-												
36	0730 100 224	Scheibe 2,0 mm	Washer	Rondelle	-	1	1	-	-												
		Pumpenantrieb	Pump drive assembly	Groupe moto - pompe																	
40	0630 502 002 14x1 DIN 472	Sicherungsring	Circlip	Circlip	2	-	-	2	2												
41	2052 322 011	Mitnehmerbuchse	Drive ring	Douille d'entraînement	2	-	-	2	2												
42	0630 502 034 68x2,5 DIN 472	Sicherungsring	Circlip	Circlip	1	-	-	1	1												

Tafel/Table/Planche 3 T - 3550 Fendt Superkriechgang, Super creep speed range, Vitesse très lente

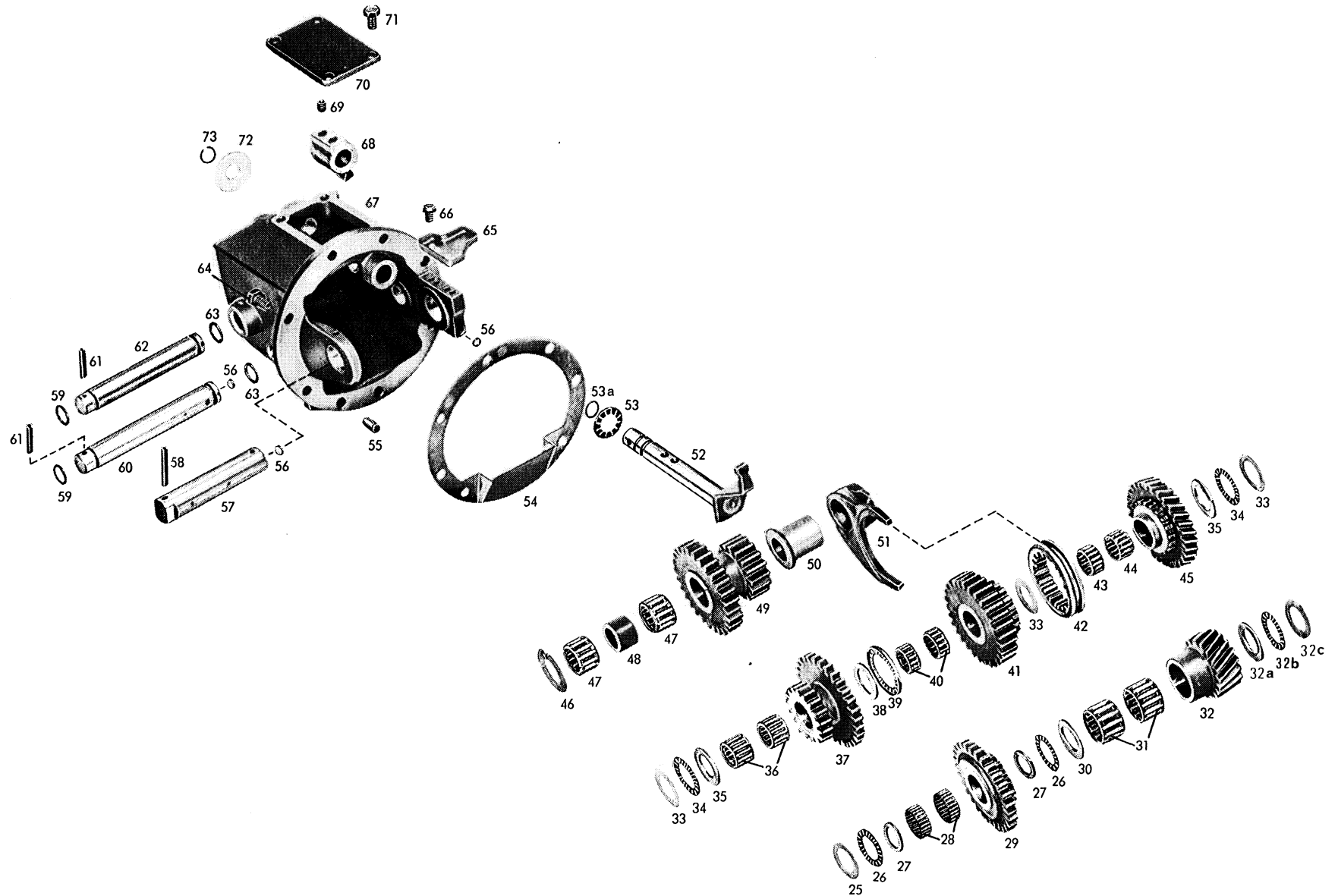

Die Abbildungen sind für die Ausführung nicht verbindlich
Illustrations are not binding for the design
Les illustrations ne sont pas obligatoires pour l'exécution

Bild Nr. Fig. No. Fig. No.	Teilnummer Partnumber No. de pièce	Benennung	Description	Désignation	0															
		Superkriechgang	Super creep speed range	Vitesse très lente																
25	0730 104 470	Scheibe	Washer	Rondelle	1															
26	0635 302 019	Axial-Nadelkäfig	Axial needle cage	Cage à aiguilles axiale	2															
27	0730 104 467	Scheibe	Washer	Rondelle	2															
28	0735 320 546	Nadelkäfig	Needle cage	Cage à aiguilles	2															
—	0735 320 547	wahlweise: Nadelkäfig	optional: Needle cage	en option: Cage à aiguilles	2															
29	2052 214 083	Doppelrad kompl.*	Dual gear ass.*	Ensemble pignon double compl.*	1															
—	2052 314 151	bestehend aus: Stirnrad	consisting of: Spur gear	composé de: Pignon droit	1															
—	2052 314 150	Stirnrad	Spur gear	Pignon droit	1															
30	0730 104 469	Scheibe	Washer	Rondelle	1															
31	0735 358 093	Nadelkäfig	Needle cage	Cage à aiguilles	2															
32	2052 314 110	Stirnrad	Spur gear	Pignon droit	1															
32a	0730 104 234	Scheibe 3,0 mm	Washer	Rondelle	1															
—	0730 104 235	wahlweise: 3,05 mm	optional:	en option:	1															
—	0730 104 236	3,15 mm			1															
—	0730 104 237	3,2 mm			1															
—	0730 104 238	3,25 mm			1															
—	0730 104 239	3,35 mm			1															
—	0730 104 240	3,4 mm			1															
—	0730 104 241	3,5 mm			1															
32b	0635 302 032	Axial-Nadelkäfig	Axial needle cage	Cage à aiguilles axiale	1															
32c	0635 290 007 30x47x1	Axial-Scheibe	Axial washer	Rondelle de butée	1															
33	0635 290 003 25x42x1	Axial-Scheibe	Axial washer	Rondelle de butée	3															
34	0635 302 011	Axial-Nadelkäfig	Axial needle cage	Cage à aiguilles axiale	2															
35	0730 104 125	Scheibe 3,0 mm	Washer	Rondelle	2															
—	0730 104 126	wahlweise: 3,05 mm	optional:	en option:	2															
—	0730 104 127	3,15 mm			2															
—	0730 104 128	3,2 mm			2															
—	0730 104 129	3,25 mm			2															
—	0730 104 130	3,35 mm			2															

Bild Nr. Fig. No. Fig. No.	Teilnummer Partnumber No. de pièce	Benennung	Description	Désignation	0															
35	0730 104 131	3,4 mm			2															
—	0730 104 132	3,5 mm			2															
—	0730 104 133	3,6 mm			2															
—	0730 104 134	3,8 mm			2															
—	0730 104 135	4,0 mm			2															
—	0730 104 136	4,2 mm			2															
36	0635 300 096	Nadelkäfig	Needle cage	Cage à aiguilles	2															
37	2052 314 148	Doppelrad	Dual gear	Pignon double	1															
38	0730 104 316	Scheibe	Washer	Rondelle	1															
39	0635 302 034	Axial - Nadelkäfig	Axial needle cage	Cage à aiguilles axiale	1															
40	0735 320 545	Nadelkäfig	Needle cage	Cage à aiguilles	2															
41	2052 314 134	Stirnrad	Spur gear	Pignon droit	1															
42	2052 314 108	Schiebemuffe	Shifter collar	Manchon coulissant	1															
43	0735 320 545	Nadelkäfig	Needle cage	Cage à aiguilles	1															
44	0750 115 061	Nadelkranz	Needle cage	Cage à aiguilles	1															
45	2052 314 109	Stirnrad	Spur gear	Pignon droit	1															
46	0730 103 041	Anlaufscheibe	Thrust washer	Rondelle de butée	1															
47	0750 115 061	Nadelkranz	Needle cage	Cage à aiguilles	2															
48	0730 161 045	Buchse	Sleeve	Douille	1															
49	2052 314 106	Doppelrad	Dual gear	Pignon double	1															
50	2052 314 119	Führungsbuchse	Guide sleeve	Douille de guidage	1															
51	2052 314 123	Schaltgabel	Shifter fork	Fourchette de commande	1															
52	2052 214 080	Schaltwelle kompl.	Shifter shaft ass.	Ensemble arbre de commande	1															
53	0632 051 016 36,6x20,4x0,4	Tellerfeder	Poppet spring	Ressort à disques	3															
53a	0634 306 015 15,3x2,4 ZFN-744	Runddichtring	Annular seal ring	Joint annulaire	1															
54	2052 214 078	Ölfangblech	Oil slinger	Deflecteur d'huile	1															
55	0631 306 072 10 M 6x18 ZFN- 6	Zylinderstift	Dowel	Goujon cylindrique	2															
56	0630 361 036 8 DIN 443	Verschlussdeckel	Sealing cover	Couvercle de fermeture	3															

Bild Nr. Fig. No. Fig. No.	Teilnummer Partnumber No. de pièce	Benennung	Description	Désignation	0	1	2	3	4	5	6	7	8	9	10	11	12	13	14	15	16	17	18	19	20	21
57	2052 314 149	Lagerbolzen	King pin	Pivot de fusée	1																					
58	0631 329 116 6x60 DIN 1481	Spannstift	Roll pin	Goupille de serrage	1																					
59	0634 303 259 25x3 ZFN - 744	Runddichtring	Annular seal ring	Joint annulaire	2																					
60	2052 314 130	Lagerbolzen	King pin	Pivot de fusée	1																					
61	0631 329 072 6x40 DIN 1481	Spannstift	Roll pin	Goupille de serrage	2																					
62	2052 314 131	Lagerbolzen	King pin	Pivot de fusée	1																					
63	0634 306 204 19x3 ZFN - 744	Runddichtring	Annular seal ring	Joint annulaire	2																					
64	0636 101 047 M 10 x 22 DIN 912 - 8.8	Zylinderschraube	Socket head screw	Vis à tête cylindrique	6																					
65	2052 314 135	Ölwanne	Oil pan	Carter d'huile	1																					
66	0636 031 054 M 6 x 12	Sicherungsschraube	Locking screw	Vis a arrêt	2																					
67	2052 314 152	Gehäuse	Housing	Carter	1																					
68	2052 314 115	Schaltnocken	Stift cam	Came de commande	1																					
69	1238 306 065	Gewindestift	Set screw	Goupille fileté	2																					
70	2052 314 122	Deckel	Cover	Couvercle	1																					
71	0636 015 147 M 10 x 18 DIN 933 - 8.8	Sechskantschraube	Hex. head screw	Vis à six pans	4																					
72	0730 150 185	Scheibe	Washer	Rondelle	1																					
73	0630 513 090 SW 20	Sprengring	Snap ring	Anneau de retenue	1																					

Tafel/Table/Planche 4 T - 3550 Fendt

Vorgelegewelle	Countershaft
Gruppengetriebe	Speed range assembly
Rücklauf	Reverse idler gear
Antriebswelle	Drive shaft
Hauptwelle	Main drive shaft
Zapfwelle	Pto - shaft
Zapfwellenschaltung	Pto - shaft shifter device

Arbre intermédiaire
Boîte - relais
Pignon libre de marche AR
Arbre d'entraînement
Arbre principal
Arbre de prise de force
Commande de l'arbre de prise de force

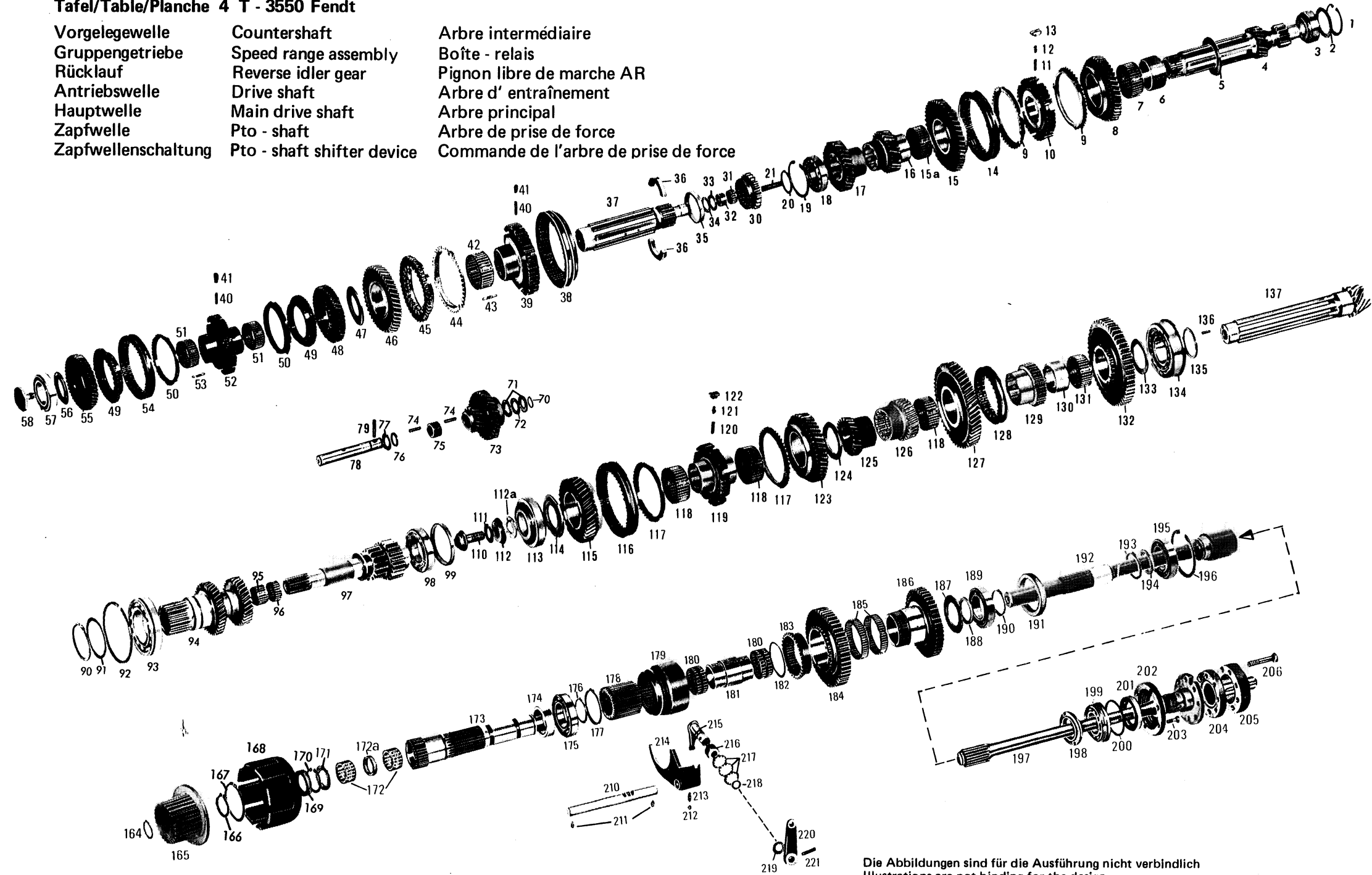

Die Abbildungen sind für die Ausführung nicht verbindlich
 Illustrations are not binding for the design
 Les illustrations ne sont pas obligatoires pour l'exécution

Tafel 4 T - 3550 Fendt Table Planche					Stückzahl nach Ausführung Quantity per model Nombre par modèle 2071 060																
Bild Nr. Fig. No. Fig. No.	Teilnummer Partnumber No. de pièce	Benennung	Description	Designation	0	0	0	0	0												
					1	1	1	1	2												
					5	7	8	9	0												
1	0630 502 122 J 3 „xO, 098“	Vorgelegewelle Sicherungsring	Countershaft Circlip	Arbre intermédiaire Circlip	1	1	1	1	1												
2	4038 303 016	Ausgleichscheibe 3,4 mm wahlweise:	Shim optional:	Cale de réglage en option:	1	1	1	1	1												
—	4038 303 062	3,2 mm			1	1	1	1	1												
—	4038 303 063	3,0 mm			1	1	1	1	1												
—	4038 303 064	2,8 mm			1	1	1	1	1												
—	4038 303 065	2,6 mm			1	1	1	1	1												
—	4038 303 066	2,4 mm			1	1	1	1	1												
—	4038 303 067	2,1 mm			1	1	1	1	1												
—	4038 303 072	1,8 mm			1	1	1	1	1												
—	4038 303 071	1,9 mm			1	1	1	1	1												
—	4038 303 070	2,0 mm			1	1	1	1	1												
—	4038 303 068	2,3 mm			1	1	1	1	1												
—	4038 303 069	2,2 mm			1	1	1	1	1												
3	0635 501 427	Lageraußenring	Bearing outer race	Bague extérieure	1	1	1	1	1												
—	0635 501 150	Lagerinnenring	Bearing inner race	Bague intérieure	1	1	1	1	1												
4	2052 303 189	Vorgelegewelle	Countershaft	Arbre intermédiaire	1	1	1	1	1												
5	0730 103 084	Anlaufscheibe	Thrust washer	Rondelle de butée	1	1	1	1	1												
6	0730 161 283	Laufbuchse	Liner	Chemise	1	1	1	1	1												
7	0750 115 081	Nadelkäfig	Needle cage	Cage a aiguilles	1	1	1	1	1												
8	2052 203 080	Stirnrad kompl. 5. Gang *	Spur gear ass. 5th speed*	Pignon droit 5ème vitesse *	1	1	1	1	1												
—	2052 303 187	Stirnrad	Spur gear	Pignon droit	1	1	1	1	1												
—	2052 315 227	Kupplungskörper	Clutch housing	Collier d' embayage	1	1	1	1	1												
9	2052 304 311	Synchronring	Synchronizer ring	Anneau de synchroniseur	2	2	2	2	2												
10	2052 303 161	Synchronkörper	Synchronizer body	Moyeu de synchroniseur	1	1	1	1	1												
11	0732 040 409	Druckfeder	Detent spring	Ressort de compression	3	3	3	3	3												
12	1249 304 323	Kugelbolzen	Ball pin	Boulon à tête sphérique	3	3	3	3	3												
13	2052 304 360	Druckstück	Pressure plate	Piece de butée	3	3	3	3	3												
14	1238 304 357	Schiebemuffe	Shifter collar	Manchon coulissant	1	1	1	1	1												
15	2052 303 200	Stirnrad 6. Gang	Spur gear 6th speed	Pignon droit 6ème vitesse	1	1	1	1	1												
15a	0750 115 080	Nadelkäfig	Needle cage	Cage à aiguilles	1	1	1	1	1												
16	2052 303 160	Stirnrad 3. Gang	Spur gear 3rd speed	Pignon droit 3ème vitesse	1	1	1	1	1												

Bild Nr. Fig. No. Fig. No.	Teilnummer Partnumber No. de pièce	Benennung	Description	Designation	0	0	0	0	0											
					1	1	1	1	2											
					5	7	8	9	0											
17	2052 303 156	Stirnrad 4. Gang	Spur gear 4th speed	Pignon droit 4ème vitesse	1	1	1	1	1											
18	0635 371 033	Rollenlager	Roller bearing	Roulement à rouleaux	1	1	1	1	1											
19	0630 502 042 90x3 DIN 472	Sicherungsring	Circlip	Circlip	1	1	1	1	1											
20	0630 531 061 48x2,5 DIN 471	Sicherungsring	Circlip	Circlip	1	1	1	1	1											
21	2052 336 058	Rohr	Pipe	Tube	1	1	1	1	1											
		Gruppengetriebe	Speed range assembly	Boîte - relais																
30	2052 315 311	Schieberad	Sliding gear	Baladeur	1	1	1	1	1											
31	0635 300 571	Nadelkranz	Needle cage	Cage à aiguilles	1	1	1	1	1											
32	0730 061 862	Buchse	Sleeve	Douille	1	1	1	1	1											
33	0730 104 132	Scheibe 3,5 mm wahlweise:	Washer optional:	Rondelle en option:	1	1	1	1	1											
-	0730 104 133	3,6 mm			1	1	1	1	1											
-	0730 105 307	3,7 mm			1	1	1	1	1											
-	0730 104 134	3,8 mm			1	1	1	1	1											
-	0730 105 308	3,9 mm			1	1	1	1	1											
-	0730 104 135	4,0 mm			1	1	1	1	1											
-	0730 105 309	4,1 mm			1	1	1	1	1											
-	0730 104 136	4,2 mm			1	1	1	1	1											
-	0730 105 310	4,3 mm			1	1	1	1	1											
-	0730 104 137	4,4 mm			1	1	1	1	1											
-	0730 104 138	4,6 mm			1	1	1	1	1											
-	0730 104 139	4,8 mm			1	1	1	1	1											
34	0635 302 011	Axial - Nadelkäfig	Axial needle cage	Cage a aiguilles axiale	1	1	1	1	1											
35	0730 061 921	Sicherungsring	Circlip	Circlip	1	1	1	1	1											
36	0730 103 201	Geteilter Ring	Split ring	Anneau fendu	1	1	1	1	1											
37	2052 315 291	Gruppenwelle	Speed range shaft	Arbre de groupe	1	1	1	1	1											
38	2052 315 308	Schiebemuffe	Shifter collar	Manchon coulissant	1	1	1	1	1											
39	2052 215 212	Synchronkörper kompl.* (Rückwärtsgruppe)	Synchronizer body ass.* (Reverse speed range)	Moyeu de synchroniseur compl.* (Groupe marche AR)	1	1	1	1	1											
		bestehend aus:	consisting of:	composé de:																
-	2052 315 292	Synchronkörper	Synchronizer body	Moyeu de synchroniseur	1	1	1	1	1											
-	2052 315 287	Scheibe	Washer	Rondelle	1	1	1	1	1											
-	0631 104 056 5x18 DIN 661	Senkniet	Countershaft rivet	Rivet noyée	3	3	3	3	3											

Bild Nr. Fig. No. Fig. No.	Teilnummer Partnumber No. de pièce	Benennung	Description	Designation	0	0	0	0	0													
					1	1	1	1	2													
					5	7	8	9	0													
40	0732 040 385	Druckfeder	Detent spring	Ressort de compression	6	6	6	6	6													
41	6002 304 628	Druckstück	Pressure plate	Piece de butée	6	6	6	6	6													
42	0750 115 081	Nadelkäfig	Needle cage	Cage à aiguilles	1	1	1	1	1													
43	0732 020 066	Zugfeder	Tension spring	Ressort de rappel	3	3	3	3	3													
44	2052 315 294	Synchronring	Synchronizer ring	Anneau de synchroniseur	1	1	1	1	1													
45	2052 315 283	Kupplungskörper	Clutch housing	Collier d'embrayage	1	1	1	1	1													
46	2052 315 337	Stirnrad (Rückwärtsgruppe)	Spur gear (Reverse speed range)	Pignon droit (Groupe marche AR)	1	1	1	1	1													
47	0730 200 167	Anlaufscheibe	Thrust washer	Rondelle de butée	1	1	1	1	1													
48	2052 315 327	Stirnrad (Zwischengruppe)	Spur gear (Splitter range)	Pignon droit (Groupe intermédiaire)	1	1	1	1	1													
49	2052 315 283	Kupplungskörper	Clutch housing	Collier d'embrayage	2	2	2	2	2													
50	2052 315 294	Synchronring	Synchronizer ring	Anneau de synchroniseur	2	2	2	2	2													
51	0750 115 080	Nadelkäfig	Needle cage	Cage à aiguilles	2	2	2	2	2													
52	2052 315 289	Synchronkörper	Synchronizer body	Moyeu de synchroniseur	1	1	1	1	1													
53	0732 020 030	Zugfeder	Tension spring	Ressort de rappel	3	3	3	3	3													
54	2052 315 306	Schiebemuffe	Shifter collar	Manchon coulissant	1	1	1	1	1													
55	2052 315 322	Stirnrad (Normal - Gruppe)	Spur gear (Normal - range)	Pignon droit (Groupe normal)	1	1	1	1	1													
56	2052 315 245	Ausgleichscheibe	Shim	Cale de réglage	1	1	1	1	1													
57	0635 416 010	Rollenlager	Roller bearing	Roulement à rouleaux	1	1	1	1	1													
58	2052 315 093	Schraube	Screw	Vis	1	1	1	1	1													
		Rücklauf	Reverse idler gear	Pignon libre de marche AR																		
70	0630 501 018 22x1,2 DIN 471	Sicherungsring	Circlip	Circlip	1	1	1	1	1													
71	0635 290 034 TWD 1427	Druckscheibe	Pressure plate	Disque de butée	2	2	2	2	2													
72	0635 302 060	Axial-Nadelkäfig	Axial needle cage	Cage à aiguilles axiale	1	1	1	1	1													
73	2052 205 046	Rücklaufrad kompl.	Reverse idler gear ass.	Pignon libre de marche AR compl.	1	1	1	1	1													
74	0735 470 026	Lagernadel	Needle	Plaque d'appui	28	28	28	28	28													

Tafel 4 T - 3550 Fendt Table Planche					Stückzahl nach Ausführung Quantity per model Nombre par modèle															
Bild Nr. Fig. No. Fig. No.	Teilnummer Partnumber No. de pièce	Benennung	Description	Désignation	0	0	0	0	0											
					1	1	1	1	2											
					5	7	8	9	0											
75	0730 160 847	Buchse	Sleeve	Douille	1	1	1	1	1											
76	0730 103 083	Scheibe	Washer	Rondelle	1	1	1	1	1											
77	0730 103 038	Anlaufscheibe	Thrust washer	Rondelle de butée	1	1	1	1	1											
78	2052 305 050	Lagerbolzen	King pin	Pivot de fusée	1	1	1	1	1											
79	0631 329 090 8x60 DIN 1481	Spannstift	Roll pin	Goupille de serrage	1	1	1	1	1											
		Antriebswelle	Drive shaft	Arbre de commande																
90	0630 501 048 75x2,5 DIN 471	Sicherungsring	Circlip	Circlip	1	1	1	1	1											
91	—	entfällt	not installed	n' est pas installé																
92	0630 503 018 SP 130 DIN 5417	Sprengring	Snap ring	Anneau de retenue	1	1	1	1	1											
93	0750 116 045	Kugellager	Ball bearing	Roulement à billes	1	1	1	1	1											
—	0630 004 124	Paßscheibe 105x130x0,3	Shim	Rondelle d' ajustage	1	1	1	1	1											
—	0630 004 229	wahlweise: 105x130x0,2	optional:	en option:	1	1	1	1	1											
—	0630 004 123	105x130x0,1 (zu Bild 93)	(ref. figure 93)	(ref. figure 93)	1	1	1	1	1											
94	2052 302 236	Zahnwelle	Gear shaft	Arbre dente	1	1	1	1	1											
95	0635 300 602	Nadelkranz	Needle cage	Cage à aiguilles	1	1	1	1	1											
96	0635 300 176	Nadelkranz	Needle cage	Cage à aiguilles	1	1	1	1	1											
97	2052 302 243	Antriebswelle	Drive shaft	Arbre de commande	1	—	1	—	1											
—	2052 302 185	Antriebswelle	Drive shaft	Arbre de commande	—	1	—	1	—											
98	0635 416 014	Rollenlager	Roller bearing	Roulement à rouleaux	1	1	1	1	1											
99	0730 260 450	Ring	Ring	Anneau	1	1	1	1	1											
		Hauptwelle	Main drive shaft	Arbre principal																
110	0736 617 024	Bundschrabe	Collar head screw	Vis à collet	1	1	1	1	1											
111	0630 602 031 21 DIN 432	Sicherungsblech	Lock plate	Frein d' écrou	1	1	1	1	1											
112	2052 304 261	Scheibe	Washer	Rondelle	1	1	1	1	1											

26 *nur komplett lieferbar/*only available as a complete unit/*a livrer seulement en ensemble/**nur von Fahrzeugfirma lieferbar/**to be delivered only by the manufacturer of the vehicle/**a livrer seulement par le constructeur du vehicule
sets Aggregat Nr. , Stücklisten - Nr. und Type angeben ! please indicate serial - No., parts list - No. and type ! indiquez toujours sur vos commandes No. de la série, No. de la liste de pieces et le type !

Bild Nr. Fig. No. Fig. No.	Teilnummer Partnumber No. de pièce	Benennung	Description	Désignation	0	0	0	0	0												
					1	1	1	1	2												
					5	7	8	9	0												
112a	0730 002 727	Scheibe 3,5 mm wahlweise:	Washer optional:	Rondelle en option:	1	1	1	1	1												
-	0730 002 728	3,4 mm			1	1	1	1	1												
-	0730 002 729	3,3 mm			1	1	1	1	1												
-	0730 002 730	3,2 mm			1	1	1	1	1												
-	0730 002 731	3,1 mm			1	1	1	1	1												
-	0730 002 732	3,0 mm			1	1	1	1	1												
-	0730 002 733	2,9 mm			1	1	1	1	1												
-	0730 002 734	2,8 mm			1	1	1	1	1												
-	0730 002 735	2,7 mm			1	1	1	1	1												
-	0730 002 736	2,6 mm			1	1	1	1	1												
-	0730 002 737	2,5 mm			1	1	1	1	1												
-	0730 002 738	2,4 mm			1	1	1	1	1												
-	0730 002 739	2,3 mm			1	1	1	1	1												
-	0730 002 743	2,2 mm			1	1	1	1	1												
-	0730 002 744	2,1 mm			1	1	1	1	1												
-	0730 002 745	2,0 mm			1	1	1	1	1												
-	0730 002 746	1,9 mm			1	1	1	1	1												
-	0730 002 747	1,8 mm			1	1	1	1	1												
-	0730 002 748	1,7 mm			1	1	1	1	1												
-	0730 002 749	1,6 mm			1	1	1	1	1												
-	0730 002 750	1,5 mm			1	1	1	1	1												
-	0730 002 751	1,4 mm			1	1	1	1	1												
-	0730 002 752	1,3 mm			1	1	1	1	1												
-	0730 002 753	1,2 mm			1	1	1	1	1												
113	0735 370 036	Kegelrollenlager	Tapered roller bearing	Roulemen à rouleaux coniques	1	1	1	1	1												
114	2052 304 290	Ausgleichscheibe 9.05 mm wahlweise:	Shim optional:	Cale de réglage en option:	1	1	1	1	1												
-	2052 304 291	8,9 mm			1	1	1	1	1												
-	2052 304 292	8,75 mm			1	1	1	1	1												
-	2052 304 293	8,6 mm			1	1	1	1	1												
-	2052 304 294	8,45 mm			1	1	1	1	1												
-	2052 304 295	8,3 mm			1	1	1	1	1												
-	2052 304 296	8,15 mm			1	1	1	1	1												
-	2052 304 297	8,0 mm			1	1	1	1	1												
-	2052 304 298	7,85 mm			1	1	1	1	1												
-	2052 304 299	7,7 mm			1	1	1	1	1												
-	2052 304 300	7,55 mm			1	1	1	1	1												
-	2052 304 301	7,4 mm			1	1	1	1	1												
-	2052 304 302	7,25 mm			1	1	1	1	1												
-	2052 304 303	7,1 mm			1	1	1	1	1												
-	2052 304 304	6,95 mm			1	1	1	1	1												
-	2052 304 305	6,8 mm			1	1	1	1	1												

Bild Nr. Fig. No. Fig. No.	Teilnummer Partnumber No. de pièce	Benennung	Description	Désignation	0	0	0	0	0										
					1	1	1	1	2										
					5	7	8	9	0										
115	2052 204 145	Stirnrad kompl. 4. Gang*	Spur gear ass. 4th speed*	Ensemble pignon droite 4éme vitesse *	1	1	1	1	1										
—	2052 304 289	bestehend aus: Stirnrad	consisting of: Spur gear	composé de: Pignon droit	1	1	1	1	1										
—	2052 315 227	Kupplungskörper	Clutch housing	Collier d' embayage	1	1	1	1	1										
116	1238 304 357	Schiebemuffe	Shifter collar	Manchon coulissant	1	1	1	1	1										
117	2052 304 311	Synchronring	Synchronizer ring	Anneau de synchroniseur	2	2	2	2	2										
118	0750 115 079	Nadelkäfig	Needle cage	Cage à aiguilles	3	3	3	3	3										
119	2052 304 319	Synchronkörper (3. und 4. Gang)	Synchronizer body (3rd and 4th speed)	Moyeu de synchroniseur (3éme et 4éme vitesse)	1	1	1	1	1										
120	0732 040 409	Druckfeder	Detent spring	Ressort de compression	3	3	3	3	3										
121	1249 304 323	Kugelbolzen	Ball pin	Boulon à tête sphérique	3	3	3	3	3										
122	2052 304 360	Druckstück	Pressure plate	Pièce de butée	3	3	3	3	3										
123	2052 304 349	Stirnrad 3. Gang wahlweise: Stirnrad	Spur gear 3rd speed optional: Spur gear	Pignon droit 3éme vitesse en option: Pignon droit	1	1	1	1	1										
—	2052 304 370				1	1	1	1	1										
124	0730 200 166	Anlaufscheibe	Thrust washer	Rondelle de butée	1	1	1	1	1										
125	2052 304 364	Stirnrad 6. Gang	Spur gear 6th speed	Pignon droit 6éme vitesse	1	1	1	1	1										
126	2052 304 365	Stirnrad 5. Gang	Spur gear 5th speed	Pignon droit 5éme vitesse	1	1	1	1	1										
127	2052 304 356	Stirnrad 2. Gang wahlweise: Stirnrad	Spur gear 2nd speed optional: Spur gear	Pignon droit 2éme vitesse en option: Pignon droit	1	1	1	1	1										
—	2052 304 376				1	1	1	1	1										
128	2052 304 246	Schiebemuffe	Shifter collar	Manchon coulissant	1	1	1	1	1										
129	2052 304 366	Muffenträger	Sleeve hub	Porte - manchon	1	1	1	1	1										
130	0730 161 204	Laufbuchse	Liner	Chemise	1	1	1	1	1										
131	0750 115 080	Nadelkranz	Needle cage	Cage à aiguilles	1	1	1	1	1										
132	2052 304 357	Stirnrad 1. Gang	Spur gear 1st speed	Pignon droit 1ére vitesse	1	1	1	1	1										
133	0730 102 942	Anlaufscheibe	Thrust washer	Rondelle de butée	1	1	1	1	1										
134	0735 370 023	Kegelrollenlager	Tapered roller bearing	Roulement à rouleaux coniques	1	1	1	1	1										
135	0730 102 633	Einstellscheibe 3,0 mm wahlweise:	Shim optional:	Cale de réglage en option:	1	1	1	1	1										
—	0730 102 634	2,8 mm			1	1	1	1	1										
—	0730 102 635	2,6 mm			1	1	1	1	1										
—	0730 102 636	2,4 mm			1	1	1	1	1										

Bild Nr. Fig. No. Fig. No.	Teilnummer Partnumber No. de pièce	Benennung	Description	Désignation	0	0	0	0	0										
					1	1	1	1	2										
					5	7	8	9	0										
135	0730 102 637	2,3 mm			1	1	1	1	1										
-	0730 102 638	2,2 mm			1	1	1	1	1										
-	0730 102 639	2,1 mm			1	1	1	1	1										
136	0631 309 008 6x20 DIN 1474	Steckkerbstift	Grooved pin	Tenon à encoche	1	1	1	1	1										
137	2052 304 353	Hauptwelle *	Main drive shaft *	Arbre principal *	1	1	1	1	1										
-	2052 309 110	Tellerrad Kpl. - Nr. 2052 204 149	Crown wheel Ass. - No. 2052 204 149	Couronne No. de l'ensemble 2052 204 149	1	1	1	1	1										
		Zapfwelle	Pto - shaft	Arbre de prise de force															
164	0630 531 043 35x2,5 DIN 471	Sicherungsring	Circlip	Circlip	1	1	1	1	1										
165	2052 213 008	Lamellenträger	Plate carrier	Tambour pur disques	1	1	1	1	1										
166	0630 531 050 40x2,5 DIN 471	Sicherungsring	Circlip	Circlip	1	1	1	1	1										
167	0630 501 046 70x2,5 DIN 471	Sicherungsring	Circlip	Circlip	1	1	1	1	1										
168	2052 313 024	Kupplungsglocke	Clutch drum	Boite de embrayage	1	1	1	1	1										
169	0734 319 074	Wellendichtring	Shaft seal	Bague d'étanchéité	1	1	1	1	1										
170	0630 502 029 55x2 DIN 472	Sicherungsring	Circlip	Circlip	1	1	1	1	1										
171	0730 101 678	Anlaufscheibe	Thrust washer	Rondelle de butée	1	1	1	1	1										
172	0635 300 613	Nadelkranz	Needle cage	Cage à aiguilles	2	2	2	2	2										
172a	0730 161 281	Buchse	Sleeve	Douille	1	1	1	1	1										
173	2052 310 215	Hohlwelle	Quill shaft	Arbre creux	1	1	1	1	1										
174	0730 160 417	Buchse	Sleeve	Douille	1	1	1	1	1										
175	0750 116 051	Kugellager	Ball bearing	Roulement à billes	1	1	1	1	1										
176	0630 501 041 60x2 DIN 471	Sicherungsring	Circlip	Circlip	1	1	1	1	1										
177	0630 501 053 88x3 DIN 471	Sicherungsring	Circlip	Circlip	1	1	1	1	1										
178	2052 310 143	Profilbuchse	Profiled bush	Douille profilée	1	1	1	1	1										
179	2052 310 187	Schaltnuffe	Shifter collar	Manchon coulissant	1	1	1	1	1										

Bild Nr. Fig. No. Fig. No.	Teilnummer Partnumber No. de pièce	Benennung	Description	Désignation	0	0	0	0	0												
					1	1	1	1	2												
					5	7	8	9	0												
180	0501 305 254	Nadelkäfig	Needle cage	Cage à aiguilles	2	2	2	2	2												
181	2052 310 142	Lagerhülse	Bearing sleeve	Coussinet	1	1	1	1	1												
182	0630 503 011 SP 85 DIN 5417	Sprengring	Snap ring	Anneau de retenue	1	1	1	1	1												
183	2052 310 138	Muffenträger	Sleeve hub	Porte - manchon	1	1	1	1	1												
184	2052 310 163	Stirnrad	Spur gear	Pignon droit	1	—	1	—	1												
—	2052 310 164	Stirnrad	Spur gear	Pignon droit	—	1	—	1	—												
185	0635 300 250	Nadelkranz	Needle cage	Cage à aiguilles	2	2	2	2	2												
186	2052 310 167	Stirnrad	Spur gear	Pignon droit	1	1	1	1	1												
187	0730 103 413	Anlaufscheibe	Thrust washer	Rondelle de butée	1	1	1	1	1												
188	0730 000 883	Scheibe 2,0 mm	Washer	Rondelle	1	1	1	1	1												
—	0730 002 771	wahlweise: 1,75 mm	optional:	en option:	1	1	1	1	1												
—	0730 002 770	1,25 mm			1	1	1	1	1												
189	0735 410 186	Rollenlager	Roller bearing	Roulement à rouleaux	1	1	1	1	1												
190	0630 501 035 50x2 DIN 471	Sicherungsring	Circlip	Circlip	1	1	1	1	1												
191	0730 062 624	Distanzring 8,5 mm	Spacing ring	Rondelle de ecartement	1	1	1	1	1												
—	0730 062 625	wahlweise: 8,8 mm	optional:	en option:	1	1	1	1	1												
—	0730 062 626	9,1 mm			1	1	1	1	1												
—	0730 062 627	9,4 mm			1	1	1	1	1												
192	2052 310 206	Zwischenwelle	Intermediate shaft	Arbre intermédiaire	1	1	1	1	1												
193	0630 501 031 40x1,75 DIN 471	Sicherungsring	Circlip	Circlip	1	1	1	1	1												
194	0630 100 010 40x50x2,5 DIN 988	Stützscheibe	Thrust disk	Rolle appui	2	2	2	2	2												
195	0735 330 147	Kugellager	Ball bearing	Roulement à billes	1	1	1	1	1												
196	0630 502 042 90x3 DIN 472	Sicherungsring	Circlip	Circlip	1	1	1	1	1												
197	2052 310 057	Zapfwelle	Pto - shaft	Arbre de prise de puissance	1	1	1	1	1												
198	0737 502 128	Nutmutter	Slotted nut	Ecrou cannelé	1	1	1	1	1												

Bild Nr. Fig. No. Fig. No.	Teilnummer Partnumber No. de pièce	Benennung	Description	Désignation	0	0	0	0	0														
					1	1	1	1	2														
					5	7	8	9	0														
199	0735 340 043	Schrägkugellager	Steep - angle ball bearing	Roulement à billes à disposition oblique	1	1	1	1	1														
200	0630 004 076	Paßscheibe 75x95x(0,2 DIN 988	Shim	Rondelle d'ajustage	1	1	1	1	1														
-	0630 000 231	wahlweise: 75x95x0,1 DIN 988	optional:	en option:	1	1	1	1	1														
201	0634 309 220	Wellendichtring	Shaft seal	Bague d'étanchéité	1	1	1	1	1														
	58x80x10/12 ZFN - 132																						
202	2052 310 031	Abschlußdeckel	Sealing cap	Couvercle de fermeture	1	1	1	1	1														
203	0636 102 013	Zylinderschraube	Socket head screw	Vis à tête cylindrique	4	4	4	4	4														
	M 8 x 25 DIN 6912 - 8.8																						
204	2052 310 207	Flanschzapfen	Flanged socket	Portée	1	1	1	1	1														
205	2052 310 040	Flansch	Flange	Bride	1	1	1	1	1														
206	0636 011 265	Sechskantschraube	Hex. head screw	Vis à six pans	8	8	8	8	8														
	M 12 x 60 DIN 931 - 10.9																						
		Zapfwellenschaltung	Pto - shaft shifter device	Commande de l'arbre de prise de force																			
210	2052 342 057	Schaltchiene	Shifter rod	Tige de commande	1	1	1	1	1														
211	1238 306 065	Gewindestift	Set screw	Goupille fileté	2	2	2	2	2														
-	0636 303 002	Verschlußschraube	Screw plug	Bouchon fileté	2	2	2	2	2														
	M 10x1 DIN 909-5.8	(zu Bild 211)	(ref. fig. 211)	(ref. fig. 211)																			
212	0635 460 021	Kugel	Ball	Bille	1	1	1	1	1														
	10 Ø DIN 5401																						
213	1203 313 004	Druckfeder	Detent spring	Ressort de compression	1	1	1	1	1														
214	2052 342 056	Schaltgabel	Shifter fork	Fourchette de commande	1	1	1	1	1														
215	2052 242 051	Schalthebel kompl.	Control lever ass.	Ensemble levier de commande	1	1	1	1	1														
216	0730 061 024	Rohr	Lubricating pipe	Tube	1	1	1	1	1														
217	0632 051 016	Tellerfeder	Poppet spring	Rondelle conique	3	3	3	3	3														
	36,6x20,4x0,4																						
218	0634 306 015	Runddichtring	Annular seal ring	Joint annulaire	1	1	1	1	1														
	15,3x2,4 ZFN - 744																						

Tafel/Table/Planche 5 T - 3550 Fendt Differential, Schaltung für Differentialsperre
 Differential assembly, Differential lock control
 Différentiel, Commande pour le verrouillage du différentiel

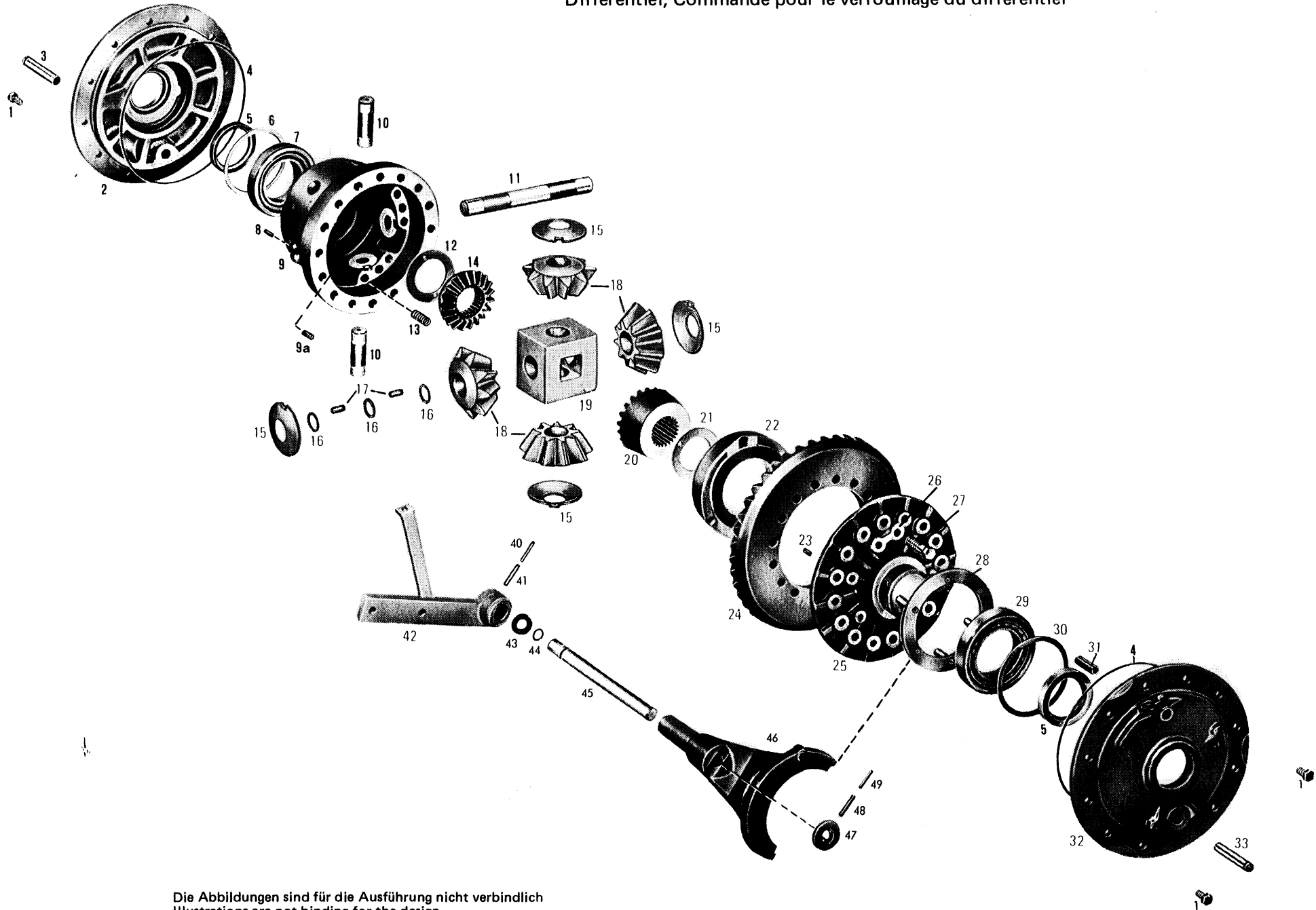

Die Abbildungen sind für die Ausführung nicht verbindlich
 Illustrations are not binding for the design
 Les illustrations ne sont pas obligatoires pour l'exécution

Tafel 5 T - 3550 Fendt Table Planche						Stückzahl nach Ausführung Quantity per model Nombre par modèle 2071 060														
Bild Nr. Fig. No. Fig. No.	Teilnummer Partnumber No. de pièce	Benennung	Description	Désignation	0 1 5	0 1 7	0 1 8	0 1 9	0 2 0											
1	0636 015 114 M 10 x 22 DIN 933 - 8.8	Differential Sechskantschraube	Differential assembly Hex. head screw	Différentiel Vis à six pans	22	22	22	22	22											
2	2052 309 142	Lagerdeckel rechts	Bearing cover R.H.	Chapeau de palier droite	1	1	1	1	1											
3	0731 201 266	Bolzen	Pin	Boulon	1	1	1	1	1											
4	0634 304 049 240x3 ZFN- 744	Runddichtring	Annular seal ring	Joint annulaire	2	2	2	2	2											
5	0734 309 042	Wellendichtring wahlweise:	Shaft seal optional:	Bague d' étanchéité en option:	2	2	2	2	2											
—	0734 309 043	Wellendichtring	Shaft seal	Bague d' étanchéité	2	2	2	2	2											
—	0734 309 044	Wellendichtring	Shaft seal	Bague d' étanchéité	2	2	2	2	2											
6	0730 002 542	Scheibe 2,0 mm wahlweise:	Washer optional:	Rondelle en option:	1	1	1	1	1											
—	0730 002 543	1,9 mm			1	1	1	1	1											
—	0730 002 544	1,8 mm			1	1	1	1	1											
—	0730 002 545	1,7 mm			1	1	1	1	1											
—	0730 002 546	1,6 mm			1	1	1	1	1											
—	0730 002 547	1,5 mm			1	1	1	1	1											
—	0730 002 548	1,4 mm			1	1	1	1	1											
—	0730 002 549	1,3 mm			1	1	1	1	1											
—	0730 002 550	1,2 mm			1	1	1	1	1											
7	0750 117 106	Rollenlager	Roller bearing	Roulement à rouleaux	1	1	1	1	1											
8	0631 329 064 6x20 DIN 1481	Spannstift	Roll pin	Goupille de serrage	4	4	4	4	4											
9	2052 209 098	Differentialgehäuse rechts kompl.*	R.H. differential housing ass.*	Ensemble boîtier de différentiel droit*	1	1	1	1	1											
—	2052 309 163	bestehend aus: Differentialgehäuse	consisting of: Differential housing	composé de: Boîtier de différentiel	1	1	1	1	1											
—	0730 260 449	Buchse	Sleeve	Douille	1	1	1	1	1											
9a	0731 305 002	Kerbstift	Grooved pin	Tenon à encoche	2	2	2	2	2											
10	2052 309 170	Bolzen	Pin	Boulon	2	2	2	2	2											
11	2052 309 171	Bolzen	Pin	Boulon	1	1	1	1	1											
12	0730 150 385	Ausgleichscheibe	Shim	Cale de réglage	1	1	1	1	1											
13	0732 040 439	Druckfeder	Detent spring	Ressort de compression	12	12	12	12	12											
14	2052 309 173	Achskegelrad rechts	R.H. differential side gear	Pignon planétaire droite	1	1	1	1	1											

Bild Nr. Fig. No. Fig. No.	Teilnummer Partnumber No. de pièce	Benennung	Description	Désignation	0 1 5	0 1 7	0 1 8	0 1 9	0 2 0									
15	0730 104 678	Anlaufscheibe	Thrust washer	Rondelle de butée	4	4	4	4	4									
16	0730 104 696	Axialscheibe	Axial washer	Rondelle de butée	12	12	12	12	12									
17	0735 470 087	Nadelrolle	Needle	Aiguille	200	200	200	200	200									
18	2052 309 168	Ausgleichkegelrad	Differential pinion	Pignon satellite	4	4	4	4	4									
19	2052 309 169	Kreuzstück	Universal joint	Croisillon	1	1	1	1	1									
20	2052 309 172	Achskegelrad links	L.H. differential side gear	Pignon planétaire gauche	1	1	1	1	1									
21	0730 150 375	Ausgleichscheibe 2,0 mm	Shim	Cale de réglage	1	1	1	1	1									
-	0730 150 376	wahlweise: 2,1 mm	optional:	en option:	1	1	1	1	1									
-	0730 150 377	2,2 mm			1	1	1	1	1									
-	0730 150 378	2,3 mm			1	1	1	1	1									
-	0730 150 379	2,4 mm			1	1	1	1	1									
-	0730 150 380	2,5 mm			1	1	1	1	1									
-	0730 150 381	2,6 mm			1	1	1	1	1									
-	0730 150 382	2,7 mm			1	1	1	1	1									
-	0730 150 383	2,8 mm			1	1	1	1	1									
-	0730 150 384	2,9 mm			1	1	1	1	1									
22	2052 309 086	Synchronring	Synchronizer ring	Anneau de synchroniseur	1	1	1	1	1									
23	0731 305 002	Kerbstift	Grooved pin	Tenon à encoche	2	2	2	2	2									
24	2052 309 110	Tellerrad *	Crown wheel *	Couronne *	1	1	1	1	1									
-	2052 304 353	Hauptwelle Kpl. - Nr. 2052 204 149	Main drive shaft Ass. - No. 2052 204 149	Arbre principal No. de l'ensemble 2052 204 149	1	1	1	1	1									
25	2052 209 094	Flansch kompl. *	Flange ass. *	Bride compl. *	1	1	1	1	1									
-	2052 309 152	bestehend aus: Flansch	consisting of: Flange	composé de: Bride	1	1	1	1	1									
-	0730 260 456	Buchse	Sleeve	Douille	1	1	1	1	1									
26	-	entfällt	not installed	n'est pas installé														
27	0636 011 023 M 12 x 50 DIN 931 - 8,8	Sechskantschraube	Hex. head screw	Vis à six pans	16	16	16	16	16									
28	2052 209 040	Ring kompl. *	Ring ass. *	Anneau compl. *	1	1	1	1	1									
-	2052 309 039	bestehend aus: Bolzen	consisting of: Pin	composé de: Boulon	6	6	6	6	6									
-	2052 309 038	Ring	Ring	Anneau	1	1	1	1	1									
29	0635 371 031	Rollenlager	Roller bearing	Roulement à rouleaux	1	1	1	1	1									

Bild Nr. Fig. No. Fig. No.	Teilnummer Partnumber No. de pièce	Benennung	Description	Désignation	0	0	0	0	0										
					1	1	1	1	2										
					5	7	8	9	0										
30	2049 309 507	Ausgleichscheibe 2,9 mm wahlweise:	Shim optional:	Cale de réglage en option:	1	1	1	1	1										
—	2049 309 090	2,8 mm			1	1	1	1	1										
—	2049 309 506	2,7 mm			1	1	1	1	1										
—	2049 309 091	2,6 mm			1	1	1	1	1										
—	2049 309 525	2,5 mm			1	1	1	1	1										
—	2049 309 524	2,4 mm			1	1	1	1	1										
—	2049 309 523	2,3 mm			1	1	1	1	1										
—	2049 309 532	2,2 mm			1	1	1	1	1										
—	2049 309 533	2,1 mm			1	1	1	1	1										
—	2049 309 534	2,0 mm			1	1	1	1	1										
—	2049 309 535	1,9 mm			1	1	1	1	1										
—	2049 309 536	1,8 mm			1	1	1	1	1										
31	0631 329 200 16x50 DIN 1481	Spannstift	Roll pin	Goupille de serrage	1	1	1	1	1										
32	2052 309 141	Lagerdeckel links	Bearing cover L.H.	Chapeau de palier gauche	1	1	1	1	1										
33	0731 201 266	Bolzen	Pin	Boulon	1	1	1	1	1										
		Schaltung für Differential- sperre	Differential lock control	Commande de verrouillage du différentiel															
40	0631 329 057 5x40 DIN 1481	Spannstift	Roll pin	Goupille de serrage	1	—	—	—	—										
41	0631 329 086 8x40 DIN 1481	Spannstift	Roll pin	Goupille de serrage	1	—	—	—	—										
42	0501 205 283	Hebel kompl. * *	Lever ass. **	Levier compl. **	1	—	—	—	—										
—	0501 205 444	Hebel kompl. **	Lever ass. **	Levier compl. **	—	1	1	1	1										
—	0631 501 074	Paßfeder	Feather Key	Clavette encastrée	—	1	1	1	1										
—	A 6x6x22 DIN 6885																		
—	0730 000 822	Scheibe	Washer	Rondelle	—	1	1	1	1										
—	0636 015 084 M 8 x 22 DIN 933 - 8.8	Sechskantschraube	Hex. head screw	Vis à six pans	—	1	1	1	1										
43	0730 102 026	Ausgleichscheibe 2,0 mm wahlweise:	Shim optional:	Cale de réglage en option:	1	1	1	1	1										
—	0730 102 027	1,5 mm			1	1	1	1	1										
—	0730 102 028	1,0 mm			1	1	1	1	1										
44	0634 303 161 17x1,5 ZFN- 744	Runddichtring	Annular seal ring	Joint annulaire	1	1	1	1	1										

Bild Nr. Fig. No. Fig. No.	Teilnummer Partnumber No. de pièce	Benennung	Description	Désignation	0	0	0	0	0												
					1	1	1	1	2												
					5	7	8	9	0												
45	2052 338 079	Welle	Shaft	Arbre	1	-	-	-	-												
-	2052 338 081	Welle	Shaft	Arbre	-	1	1	1	1												
46	2052 338 072	Schaltgabel	Shifter fork	Fourchette de commande	1	1	1	1	1												
47	2052 338 030	Nocken	Cam	Came	1	1	1	1	1												
48	0631 329 086 8x40 DIN 1481	Spannstift	Roll pin	Goupille de serrage	1	1	1	1	1												
49	0631 329 057 5x40 DIN 1481	Spannstift	Roll pin	Goupille de serrage	1	1	1	1	1												

Tafel/Table/Planche 6 T - 3550 Fendt

Abtrieb rechts und links, Bremsen, Feststellbremsbetätigung
 Final drive RH and LH, Brake assemblies, Parking brake actuation
 Sortie droite et gauche, Ensemble freins, Commande du frein de stationnement

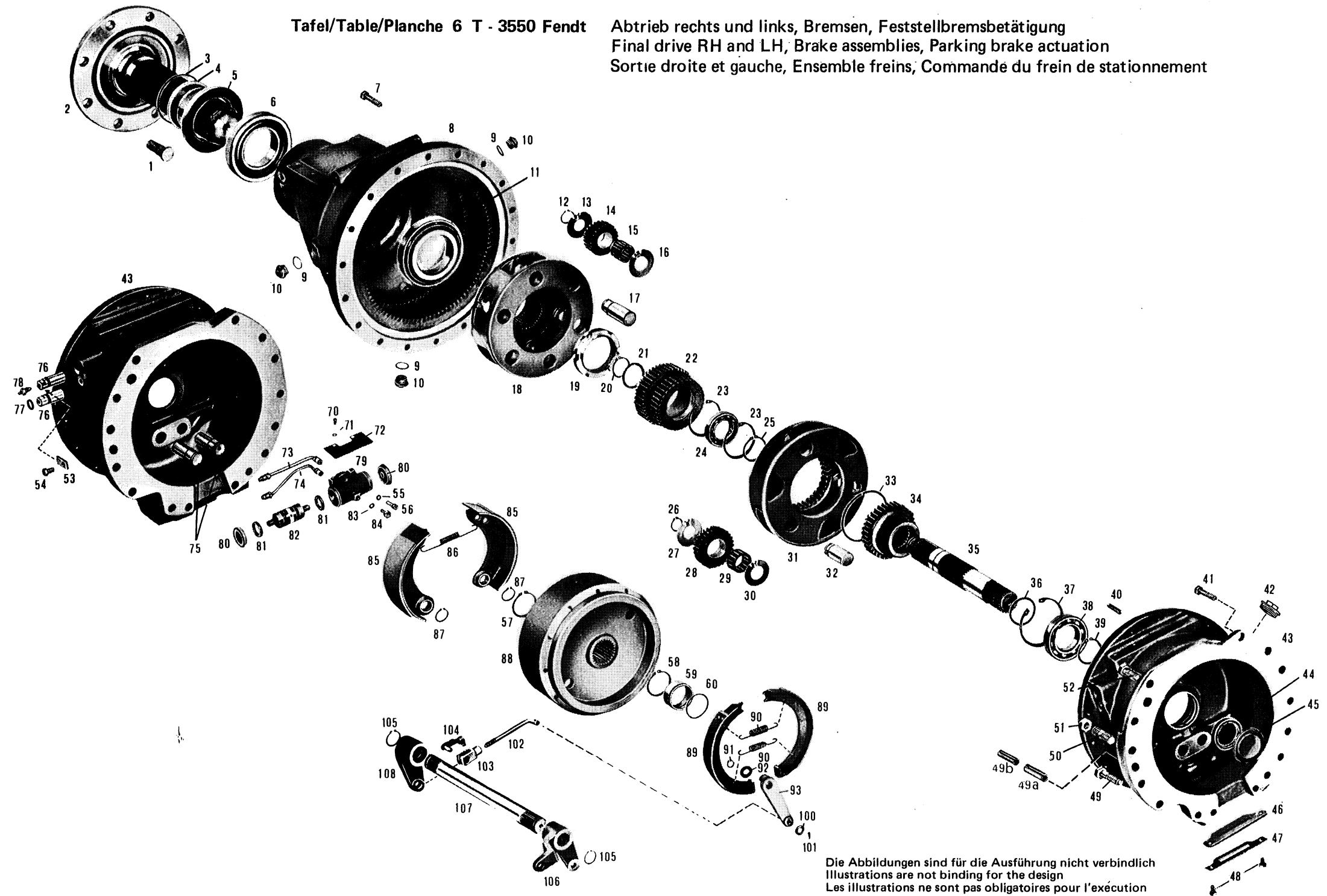

Die Abbildungen sind für die Ausführung nicht verbindlich
 Illustrations are not binding for the design
 Les illustrations ne sont pas obligatoires pour l'exécution

Tafel 6 T - 3550 Fendt Table Planche					Stückzahl nach Ausführung Quantity per model Nombre par modèle															
					2071 060															
Bild Nr. Fig. No. Fig. No.	Teilnummer Partnumber No. de pièce	Benennung	Description	Désignation	0	0	0	0	0											
					0	1	1	1	2											
					5	7	8	9	0											
		Abtrieb rechts und links	R.H. and L.H. final drive	Sortie droite et gauche																
1	4401 303 053	Radbefestigungsbolzen	Wheel mounting bolt	Vis fixation roue	16	16	16	16	16											
2	2071 211 013	Hinterachswelle kompl.* bestehend aus:	Rear axle shaft ass.* consisting of:	Ensemble arbre du pont AR* composé de:	2	2	2	2	2											
—	2071 311 163	Welle	Shaft	Arbre	2	2	2	2	2											
—	2071 311 174	Flansch	Flange	Bride	2	2	2	2	2											
3	0634 306 302 105x3 ZFN - 744	Runddichtring	Annular seal ring	Joint annulaire	2	2	2	2	2											
4	2071 311 164	Buchse	Sleeve	Douille	2	2	2	2	2											
5	0734 300 068	Wellendichtring	Shaft seal	Bague d'étanchéité	2	2	2	2	2											
6	0750 117 042	Rollenlager	Roller bearing	Roulement à rouleaux	2	2	2	2	2											
7	0636 011 265 M 12 x 60 DIN 931 - 10.9	Sechskantschraube	Hex. head screw	Vis à six pans	36	36	36	36	36											
8	2071 211 012	Achsrohr kompl.* bestehend aus:	Axle box ass.* consisting of:	Ensemble trompette du pont AR* composé de:	2	2	2	2	2											
—	2071 311 153	Achsrohr	Axle box	Trompette du pont AR	2	2	2	2	2											
—	2071 311 166	Hohlrad	Internal gear	Roue à denture intérieure	2	2	2	2	2											
—	2071 311 175	Blechring	Sheet - metal ring	Bague de tôle	2	2	2	2	2											
—	2071 311 165	Hohlrad	Internal gear	Roue à denture intérieure	2	2	2	2	2											
9	0634 801 200 A 24x29 DIN 7603	Dichtring	Seal ring	Rondelle d'étanchéité	6	6	6	6	6											
10	0736 304 017	Verschlußschraube	Screw plug	Bouchon fileté	6	6	6	6	6											
11	0635 371 015	Rollenlager	Roller bearing	Roulement à rouleaux	2	2	2	2	2											
12	0630 501 024 30x1,5 DIN 471	Sicherungsring	Circlip	Circlip	12	12	12	12	12											
13	0730 103 287	Anlaufscheibe	Thrust washer	Rondelle de butée	12	12	12	12	12											
14	2071 311 093	Planetenrad	Planetary pinion	Roue planétaire	12	12	12	12	12											
15	0735 320 252	Nadelkäfig	Needle cage	Cage à aiguilles	12	12	12	12	12											
16	0730 103 288	Anlaufscheibe	Thrust washer	Rondelle de butée	12	12	12	12	12											
17	2071 311 091	Bolzen	Pin	Boulon	12	12	12	12	12											
18	2071 311 087	Planetenträger	Planetary carrier	Cage de transmission planétaire	2	2	2	2	2											
19	0737 502 103	Nutmutter	Slotte nut	Ecrou cannelé	2	2	2	2	2											

Bild Nr. Fig. No. Fig. No.	Teilnummer Partnumber No. de pièce	Benennung	Description	Désignation	0	0	0	0	0												
					1	1	1	1	2												
					5	7	8	9	0												
20	0630 531 061 48x2,5 DIN 471	Sicherungsring	Circlip	Circlip	2	2	2	2	2												
21	0730 000 883	Scheibe	Washer	Rondelle	2	2	2	2	2												
22	2071 311 161	Sonnenrad	Sun gear	Roue solaire	2	2	2	2	2												
23	0630 502 042 90x3 DIN 472	Sicherungsring	Circlip	Circlip	4	4	4	4	4												
24	0750 116 034	Kugellager	Ball bearing	Roulement à billes	2	2	2	2	2												
25	0630 531 073 58x3 DIN 471	Sicherungsring	Circlip	Circlip	2	2	2	2	2												
26	0630 501 024 30x1,5 DIN 471	Sicherungsring	Circlip	Circlip	6	6	6	6	6												
27	0730 103 287	Anlaufscheibe	Thrust washer	Rondelle de butée	6	6	6	6	6												
28	2071 311 094	Planetenrad	Planetary pinion	Roue planétaire	6	6	6	6	6												
29	0735 358 069	Nadelkäfig	Needle cage	Cage à aiguilles	6	6	6	6	6												
30	0730 103 288	Anlaufscheibe	Thrust washer	Rondelle de butée	6	6	6	6	6												
31	2071 311 157	Planetenträger	Planetary carrier	Cage de transmission planétaire	2	2	2	2	2												
32	2071 311 092	Bolzen	Pin	Boulon	6	6	6	6	6												
33	0630 513 011 SW 135	Sprengring	Snap ring	Anneau de retenue	2	2	2	2	2												
34	2071 311 160	Sonnenrad	Sun gear	Roue solaire	2	2	2	2	2												
35	2071 311 156	Seitenwelle rechts	Side shaft R.H.	Arbre latéral droite	1	1	1	1	1												
—	2071 311 155	Seitenwelle links	Side shaft L.H.	Arbre latéral gauche	1	1	1	1	1												
36	0630 526 007	Ausgleichscheibe	Shim	Cale de réglage	2	2	2	2	2												
37	0630 502 047 110x4 DIN 472	Sicherungsring	Circlip	Circlip	2	2	2	2	2												
38	0750 116 051	Kugellager	Ball bearing	Roulement à billes	2	2	2	2	2												
39	0630 531 076 60x3 DIN 471	Sicherungsring	Circlip	Circlip	2	2	2	2	2												
40	0631 329 100 ¹ 10x40 DIN 1481	Spannstift	Roll pin	Goupille de serrage	6	6	6	6	6												
41	0636 016 040 M 16 x 35 DIN 933 - 10.9	Sechskantschraube (zu Bremsgehäuse rechts)	Hex. head screw (ref. brake housing R.H.)	Vis à six pans (ref. boîtier de frein droite)	1	1	1	1	1												

Bild Nr. Fig. No. Fig. No.	Teilnummer Partnumber No. de pièce	Benennung	Description	Désignation	0	0	0	0	0												
					1	1	1	1	2												
					5	7	8	9	0												
—	0636 611 172 M 16 x 35 DIN 939 - 10.9	Stiftschraube (zu Bremsgehäuse links)	Set screw (ref. brake housing L.H.)	Vis sans tête (ref. boîtier de frein gauche)	1	1	1	1	1												
42	0015 300 158	Verschlussschraube	Screw plug	Bouchon fileté	2	2	2	2	2												
43	2071 311 195	Bremsgehäuse rechts	Brake housing R.H.	Boîtier de frein droite	1	1	1	1	1												
—	2071 311 194	Bremsgehäuse links	Brake housing L.H.	Boîtier de frein gauche	1	1	1	1	1												
44	0734 309 041	Wellendichtring	Shaft seal	Bague d'étanchéité	2	2	2	2	2												
45	2068 311 229	Schutzring	Protection ring	Anneau de garde	2	2	2	2	2												
46	2068 311 301	Schutzbalg	Bellow	Soufflet	2	2	2	2	2												
47	2068 311 300	Abdeckblech	Cover plate	Tôle de protection	2	2	2	2	2												
48	0636 015 147 M 10 x 18 DIN 933 - 8.8	Sechskantschraube	Hex. head screw	Vis à six pans	4	4	4	4	4												
49	0636 011 241 M 16 x 70 DIN 931 - 10.9	Sechskantschraube	Hex. head screw	Vis à six pans	14	14	14	14	14												
49a	0631 329 219 16x60 DIN 1481	Spannstift	Roll pin	Goupille de serrage	2	2	2	2	2												
49b	0631 329 218 10x60 DIN 1481	Spannstift	Roll pin	Goupille de serrage	2	2	2	2	2												
50	0636 611 178 M 16 x 65 DIN 939 - 10.9	Stiftschraube	Set screw	Vis sans tête	8	8	8	8	8												
51	0637 006 066 M 16 DIN 934 - 10	Sechskantmutter	Hex. nut	Ecrou à six pans	9	9	9	9	9												
52	0636 016 086 M 16 x 45 DIN 933 - 10.9	Sechskantschraube	Hex. head screw	Vis à six pans	5	5	5	5	5												
53	2068 311 199	Halteblech	Retaining plate	Bague - cornieré	2	2	2	2	2												
54	0636 015 147 M 10 x 18 DIN 933 - 8.8	Sechskantschraube	Hex. head screw	Vis à six pans	2	2	2	2	2												
55	0630 305 002 8 DIN 7980	Federring	Spring washer	Rondelle grower	4	4	4	4	4												

Bild Nr. Fig. No. Fig. No.	Teilnummer Partnumber No. de pièce	Benennung	Description	Désignation	0	0	0	0	0											
					1	1	1	1	2											
					5	7	8	9	0											
56	0636 101 031 M 8 x 30 DIN 912 - 8.8	Zylinderschraube	Socket head screw	Vis à tête cylindrique	4	4	4	4	4											
57	0630 501 041 60x2 DIN 471	Sicherungsring	Circlip	Circlip	2	2	2	2	2											
58	0630 501 040 58x2 DIN 471	Sicherungsring	Circlip	Circlip	2	2	2	2	2											
59	2068 311 194	Buchse	Sleeve	Douille	2	2	2	2	2											
60	0634 306 509 55x3 ZFN- 744	Runddichtring	Annular seal ring	Joint annulaire	2	2	2	2	2											
Bremsen					Brake assemblies					Ensemble frein										
70-76 u. 78-93	0501 002 361	Doppelbremse 270x80/250x30 Type 27 - 1877 rechts	Dual brake 270x80/250x30 Type 27 - 1877 R.H.	Frein double 270x80/250x30 Type 27 - 1877 droite	1	1	1	1	1											
-	0501 002 362	Doppelbremse 270x80/250x30 Type 17 - 1877 links	Dual brake 270x80/250x30 Type 27 - 1877 L.H.	Frein double 270x80/250x30 Type 27 - 1877 gauche	1	1	1	1	1											
70	0636 015 032 M 6 x 10 DIN 933 - 8.8	Sechskantschraube	Hex. head screw	Vis à six pans	4	4	4	4	4											
71	0630 302 060 B 6 DIN 137	Federscheibe	Spring washer	Rondelle elastique	4	4	4	4	4											
72	0501 304 901	Schutzblech	Protection plate	Protection	2	2	2	2	2											
73	0501 304 902	Bremsrohr rechts (Entlüftungsrohr)	Brake line R.H. (Bleeder pipe)	Conduite de frein droite (Tube d' evacuation)	1	1	1	1	1											
74	0501 304 903	Bremsrohr rechts (Druckrohr)	Brake line R.H. (Hydraulic pipe)	Conduite de frein droite (Tube d' refoulement)	1	1	1	1	1											
-	0501 305 108	Bremsrohr links (Entlüftungsrohr)	Brake line L.H. (Bleeder pipe)	Conduite de frein gauche (Tube d' evacuation)	1	1	1	1	1											
-	0501 305 109	Bremsrohr links (Druckrohr)	Brake line L.H. (Hydraulic pipe)	Conduite de frein gauche (Tube d' refoulement)	1	1	1	1	1											
75	0501 304 906	Ankerbolzen	Anchor pin	Boulon d' ancrage	4	4	4	4	4											
76	0501 306 325	Zwischenstück	Spacer	Pièce intermédiaire	4	4	4	4	4											
77	0634 306 194 16x3 ZFN- 744	Runddichtring	Annular seal ring	Joint annulaire	4	4	4	4	4											
78	0501 200 072	Entlüfterventil	Bleeder valve	Vis de purge	2	2	2	2	2											

Bild Nr. Fig. No. Fig. No.	Teilnummer Partnumber No. de pièce	Benennung	Description	Désignation	0	0	0	0	0											
					1	1	1	1	2											
					5	7	8	9	0											
79-84	0501 001 693	Radzylinder kompl.*	Wheel cylinder ass.*	Ensemble cylindre frein de roue*	2	2	2	2	2											
85	0501 204 464	Bremsbacke mit Belag	Brake shoe with lining	Machoire avec garniture	4	4	4	4	4											
86	0501 305 147	Zugfeder	Tension spring	Ressort de rappel	2	2	2	2	2											
87	0630 501 024 30x1,5 DIN 471	Sicherungsring	Circlip	Circlip	4	4	4	4	4											
88	0501 304 900	Bremstrommel	Brake drum	Tambour de frein	2	2	2	2	2											
89	0501 202 561	Bremsbacke mit Belag	Brake shoe with lining	Machoire avec garniture	4	4	4	4	4											
90	0501 300 460	Zugfeder	Tension spring	Ressort de rappel	4	4	4	4	4											
91	0630 501 012 16x1 DIN 471	Sicherungsring	Circlip	Circlip	2	2	2	2	2											
92	0501 300 408	Beilagscheibe	Plein washer	Rondelle plate	2	2	2	2	2											
93	0501 203 938	Bremsnocke rechts	Brake cam R.H.	Came de frein droite	1	1	1	1	1											
—	0501 203 939	Bremsnocke links	Brake cam L.H.	Came de frein gauche	1	1	1	1	1											
		Feststellbremsbetätigung	Parking brake actuation	Manoeuvre du frein de stationnement																
100	0630 001 016 A 13 DIN 125	Scheibe	Washer	Rondelle	2	2	2	2	2											
101	0631 701 035 4x20 DIN 94	Splint	Cotter pin	Goupille fendue	2	2	2	2	2											
102	2052 325 091	Zugstange	Tie rod	Barre d'accouplement	2	2	2	2	2											
103	0632 101 007 G 12 x 24 DIN 71 752	Gabelkopf	Yoke	Chabe	2	2	2	2	2											
104	0631 225 011 12x24 SXN - 01	Bolzen	Pin	Boulon	2	2	2	2	2											
105	0630 501 023 29x1,5 DIN 471	Sicherungsring	Circlip	Circlip	2	2	2	2	2											
106	2052 325 084	Bremshebel links	Brake lever L.H.	Levier de frein gauche	1	1	1	1	1											
107	2052 325 001	Bremswelle	Brake shaft	Axe de frein	1	1	1	1	1											
108	2052 325 003	Bremshebel rechts	Brake lever R.H.	Levier de frein droite	1	1	1	1	1											

Tafel/Table/Planche 7 T - 3550 Fendt

Vorderradantrieb

Front - Wheel drive

Mécanisme de pont AV

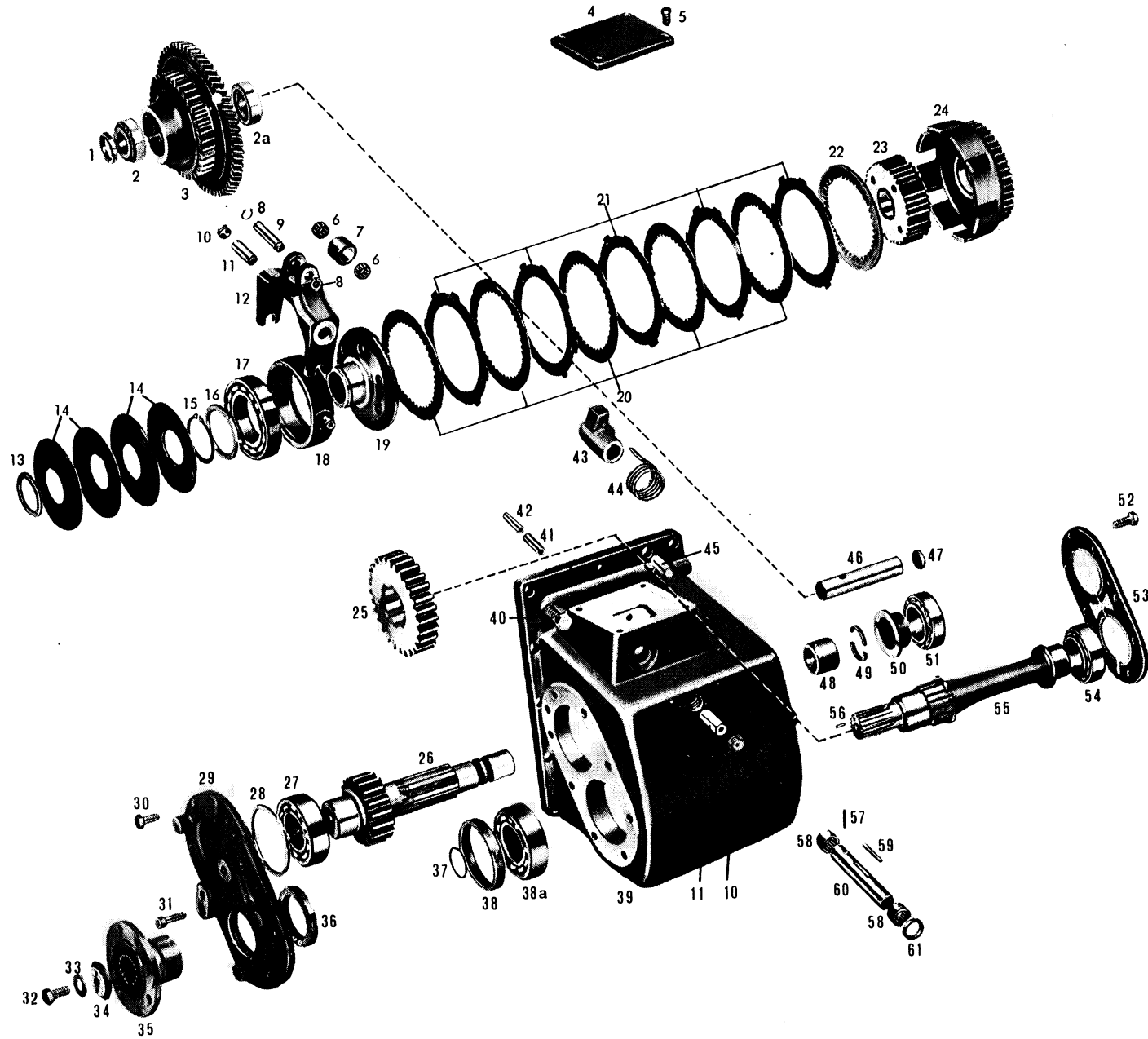

Die Abbildungen sind für die Ausführung nicht verbindlich
Illustrations are not binding for the design
Les illustrations ne sont pas obligatoires pour l'exécution

Bild Nr. Fig. No. Fig. No.	Teilnummer Partnumber No. de pièce	Benennung	Description	Désignation	0	0	0	0	0													
					1	1	1	1	2													
					5	7	8	9	0													
		Vorderradantrieb	Front wheel drive	Mécanisme de pont AV																		
1	0730 062 214	Ring 6,7 mm wahlweise:	Ring optional:	Anneau en option:	1	1	1	1	1													
—	0730 062 215	6,6 mm			1	1	1	1	1													
—	0730 062 216	6,5 mm			1	1	1	1	1													
—	0730 062 217	6,4 mm			1	1	1	1	1													
—	0730 062 218	6,3 mm			1	1	1	1	1													
—	0730 062 219	6,2 mm			1	1	1	1	1													
—	0730 062 220	6,1 mm			1	1	1	1	1													
—	0730 062 221	6,0 mm			1	1	1	1	1													
—	0730 062 222	5,9 mm			1	1	1	1	1													
—	0730 062 223	5,8 mm			1	1	1	1	1													
2	0635 373 019	Rollenlager	Roller bearing	Roulement à rouleaux	1	1	1	1	1													
2a	0750 117 043	Rollenlager	Roller bearing	Roulement à rouleaux	1	1	1	1	1													
3	2052 346 532	Doppelstirnrad Kennzahl 51 SU/617	Dual spur gear Index 51 SU/617	Pignon droit double Repère 51 SU/617	1	1	1	1	1													
4	2052 346 324	Deckel	Cover	Couvercle	1	1	1	1	1													
5	0636 015 060 M 8 x 12 DIN 933 - 8.8	Sechskantschraube	Hex. head screw	Vis à six pans	4	4	4	4	4													
6	0635 300 512	Nadelkäfig	Needle cage	Cage à aiguilles	2	2	2	2	2													
7	0730 160 252	Rolle	Roller	Rouleau	1	1	1	1	1													
8	0630 501 008 12x1 DIN 471	Sicherungsring	Circlip	Circlip	2	2	2	2	2													
9	2049 346 044	Bolzen	Pin	Boulon	1	1	1	1	1													
10	0636 301 006 M 18 x 1,5 DIN 906 - 5.8	Verschlußschraube	Screw plug	Bouchon fileté	2	2	2	2	2													
11	0731 201 058	Bolzen	Pin	Boulon	2	2	2	2	2													
12	2052 246 252	Ausrückgabel kompl.* bestehend aus:	Shifter yoke ass.* consisting of:	Ensemble fourchette de débrayage* composé de:	1	1	1	1	1													
—	2052 346 482	Ausrückgabel	Shifter yoke	Fourchette de débrayage	1	1	1	1	1													
—	0730 260 087	Buchse	Sleeve	Douille	2	2	2	2	2													
13	0730 100 980	Einstellscheibe 5,0 mm wahlweise:	Shim optional:	Cale de réglage en option:	1	1	1	1	1													
—	0730 100 981	4,5 mm			1	1	1	1	1													
—	0730 100 982	4,0 mm			1	1	1	1	1													

Bild Nr. Fig. No. Fig. No.	Teilnummer Partnumber No. de pièce	Benennung	Description	Désignation	0	0	0	0	0										
					1	1	1	1	2										
					5	7	8	9	0										
13	0730 100 983	3,5 mm			1	1	1	1	1										
—	0730 100 984	3,0 mm			1	1	1	1	1										
—	0730 100 985	2,5 mm			1	1	1	1	1										
—	0730 100 986	2,0 mm			1	1	1	1	1										
14	2052 246 213	Federsäule kompl.* bestehend aus:	Spring pack ass.* consisting of:	Ensemble de rondelle coniques*	1	1	1	1	1										
—	0732 000 010	Tellerfeder	Poppet spring	Rondelle conique	4	4	4	4	4										
15	0630 501 044 65x2,5 DIN 471	Sicherungsring	Circlip	Circlip	1	1	1	1	1										
16	0730 100 668	Abstandscheibe	Spacing washer	Rondelle d'ecartement	1	1	1	1	1										
17	0750 116 037	Schräggugellager	Steep - angle ball bearing	Roulement à billes à disposition optique	1	1	1	1	1										
18	2049 346 029	Druckring	Thrust ring	Anneau de butée	1	1	1	1	1										
19	2052 346 352	Druckstück	Pressure piece	Butee	1	1	1	1	1										
20	2049 346 087	Innenlamelle	Drive plate	Disque intérieur	6	6	6	6	6										
21	2052 246 270	Außenlamelle	Driven plate	Disque extérieur	6	6	6	6	6										
22	2049 346 033	Druckscheibe	Pressure plate	Rondelle de butée	1	1	1	1	1										
23	2052 346 481	Lamellenträger	Plate carrier	Tambour pour disques	1	1	1	1	1										
24	2052 246 264	Stirnrad mit Kupplungsglocke kompl. Kennzahl 51 SU/617	Spur gear with clutch drum ass. Index 51 SU/617	Ensemble pignon droit avec carter d'embrayage Repère 51 SU/617	1	1	1	1	1										
25	2052 346 429	Stirnrad	Spur gear	Pignon droit	1	1	1	1	1										
26	2052 346 430	Stirnradwelle	Spur gear shaft	Arbre de pignon droit	1	1	1	1	1										
27	0750 117 068	Kegelrollenlager	Tapered roller bearing	Roulement à rouleaux coniques	1	1	1	1	1										
28	0730 102 103	Ausgleichscheibe 2,8 mm wahlweise:	Shim optional:	Cale de réglage en option:	1	1	1	1	1										
—	0730 102 104	2,75 mm			1	1	1	1	1										
—	0730 102 105	2,7 mm			1	1	1	1	1										
—	0730 102 106	2,65 mm			1	1	1	1	1										
—	0730 102 060	2,6 mm			1	1	1	1	1										
—	0730 102 061	2,55 mm			1	1	1	1	1										
—	0730 102 062	2,5 mm			1	1	1	1	1										
—	0730 102 063	2,45 mm			1	1	1	1	1										
—	0730 102 064	2,4 mm			1	1	1	1	1										
—	0730 102 065	2,35 mm			1	1	1	1	1										
—	0730 102 066	2,3 mm			1	1	1	1	1										

Tafel Table Planche		7 T - 3550 Fendt			Stückzahl nach Ausführung Quantity per model Nombre par modèle																		
					2071 060																		
Bild Nr. Fig. No. Fig. No.	Teilnummer Partnumber No. de pièce	Benennung	Description	Désigantion	0	0	0	0	0														
					1	1	1	1	2														
					5	7	8	9	0														
28	0730 102 067	2,25 mm			1	1	1	1	1														
—	0730 102 068	2,2 mm			1	1	1	1	1														
—	0730 102 069	2,15 mm			1	1	1	1	1														
—	0730 102 070	2,1 mm			1	1	1	1	1														
—	0730 102 071	2,05 mm			1	1	1	1	1														
—	0730 102 072	2,0 mm			1	1	1	1	1														
—	0730 102 073	1,95 mm			1	1	1	1	1														
—	0730 102 074	1,9 mm			1	1	1	1	1														
—	0730 102 075	1,85 mm			1	1	1	1	1														
—	0730 102 700	1,8 mm			1	1	1	1	1														
29	2052 346 426	Gehäusedeckel vorne	Housing cover, front	Couvercle du carter AV	1	1	1	1	1														
30	0636 015 166 M 10 x 25 DIN 933 - 10.9	Sechskantschraube	Hex. head screw	Vis à six pans	6	6	6	6	6														
—	0636 102 094 M 10 x 22 DIN 6912 - 10.9	Zylinderschraube	Socket head screw	Vis à tête cylindrique	1	1	1	1	1														
31	0636 101 100 M 10 x 30 DIN 912 - 10.9	Zylinderschraube	Socket head screw	Vis à tête cylindrique	1	1	1	1	1														
32	0636 016 009 M 12 x 25 DIN 933 - 8.8	Sechskantschraube	Hex. head screw	Vis à six pans	1	1	1	1	1														
33	0630 602 004 13 DIN 432	Sicherungsblech	Lock plate	Frein d'écrou	1	1	1	1	1														
34	2049 346 096	Scheibe	Washer	Rondelle	1	1	1	1	1														
35	2052 346 386	Abtriebsflansch	Output flange	Bride de sortie	1	1	1	1	1														
—	0636 020 299 M 10 x 1 x 60 DIN 960 - 10.9	Sechskantschraube	Hex. head screw	Vis à six pans	8	8	8	8	8														
36	0634 309 220 58x80x10/12 ZFN - 132	Wellendichtring	Shaft seal	Bague d'étanchéité	1	1	1	1	1														
37	0634 306 247 40x2 ZFN - 744	Runddichtring	Annular seal ring	Joint annulaire	1	1	1	1	1														
38	0730 062 240	Distanzring 8,9 mm	Spacing ring	Rondelle de écartément	1	1	1	1	1														
—	0730 062 241	wahlweise: 8,7 mm	optional:	en option:	1	1	1	1	1														
—	0730 062 242	8,5 mm			1	1	1	1	1														

Bild Nr. Fig. No. Fig. No.	Teilnummer Partnumber No. de pièce	Benennung	Description	Désignation	0	0	0	0	0												
					1	1	1	1	2												
					5	7	8	9	0												
38	0730 062 243	8,4 mm			1	1	1	1	1												
—	0730 062 244	8,3 mm			1	1	1	1	1												
—	0730 062 245	8,2 mm			1	1	1	1	1												
—	0730 062 246	8,1 mm			1	1	1	1	1												
38a	0635 501 021	Lageraußenring	Bearing outer race	Bague extérieure	1	1	1	1	1												
—	0635 501 022	Lagerinnenring	Bearing inner race	Bague intérieure	1	1	1	1	1												
39	2052 346 431	Gehäuse	Housing	Carter	1	1	1	1	1												
40	0636 016 015 M 12 x 35 DIN 933 - 8.8	Sechskantschraube	Hex. head screw	Vis à six pans	11	11	11	11	11												
41	0631 329 072 6x40 DIN 1481	Spannstift	Roll pin	Goupille de serrage	1	1	1	1	1												
42	0631 329 145 3,5x40 DIN 1481	Spannstift	Roll pin	Goupille de serrage	1	1	1	1	1												
43	2052 346 323	Nocken	Cam	Came	1	1	1	1	1												
44	0732 010 002	Drehfeder	Torsion spring	Ressort de torsion	1	1	1	1	1												
45	0631 306 081 12 M 6x30 ZFN- 6	Zylinderstift	Dowel	Goujon cylindrique	2	2	2	2	2												
46	2052 346 427	Lagerbolzen	King pin	Pivot de fusée	1	1	1	1	1												
47	0630 361 029 30 DIN 443	Deckel	Cover	Couvercle	1	1	1	1	1												
48	0730 160 135	Zwischenrohr	Spacer sleeve	Entretoise	1	1	1	1	1												
49	0730 100 708	Geteilte Ring	Split ring	Anneau divisé	1	1	1	1	1												
50	2052 346 428	Anlaufbuchse	Collar sleeve	Douille de butée	1	1	1	1	1												
51	0750 117 076	Rollenlager	Roller bearing	Roulement à rouleaux	1	1	1	1	1												
52	0636 015 110 M 10 x 20 DIN 933 - 8.8	Sechskantschraube	Hex. head screw	Vis à six pans	8	8	8	8	8												
53	2052 346 066	Gehäusedeckel hinten	Housing cover, rear	Couvercle du carter AR	1	1	1	1	1												
54	0635 501 175	Lageraußenring	Bearing outer race	Bague extérieure	1	1	1	1	1												
—	0635 501 006	Lagerinnenring	Bearing inner race	Bague intérieure	1	1	1	1	1												
55	2052 346 483	Abtriebswelle	Output shaft	Arbre de sortie	1	1	1	1	1												
56	0631 308 026 5x12 DIN 1473	Kerbstift	Grooved pin	Clou cannelé	1	1	1	1	1												

Bild Nr. Fig. No. Fig. No.	Teilnummer Partnumber No. de pièce	Benennung	Description	Désignation	0	0	0	0	0												
					1	1	1	1	2												
					5	7	8	9	0												
57	0631 329 158 3x32 DIN 1481	Spannstift	Roll pin	Goupille de serrage	1	1	1	1	1												
58	0635 303 050	Nadelhülse	Needle bush	Douille aiguilles	2	2	2	2	2												
59	0631 501 412 B 6x4x36 DIN 6885	Paßfeder	Adjusting spring	Ressort d'ajustage	1	1	1	1	1												
60	2052 346 382	Schaltwelle	Shifter shaft	Arbre de commande	1	1	1	1	1												
61	0634 300 229 20x30x7 ZFN - 132	Wellendichtring	Shaft seal	Bague d'étanchéité	1	1	1	1	1												

