

**ERSATZTEIL-LISTE  
SPARE PARTS LIST  
LISTE DES PIECES DE  
RECHANGE**

Änderungen vorbehalten!  
With the reserve of modifications!  
Modifications reserves!

**ZF- SCHLEPPERTRIEBWERK  
ZF-TRACTOR TRANSMISSION  
ENSEMBLE BOITE-PONT ZF  
POUR TRACTEURS AGRICOLES**

**T-3550**

Stückliste Nr.: / Parts list No.: / Liste de pieces No.: 2071 060 023/024



**ZF Passau GmbH**

**Donaustr. 25 - 71**

**D- 94 034 Passau**

Ausgabe: 12.86

## LIEFERBEDINGUNGEN FÜR ERSATZTEILE

Bestellungen von Ersatzteilen sollen stets folgende Angaben enthalten, um eine richtige und schnelle Lieferung zu sichern:

1. Type
2. Aggregatnummer
3. Stücklistennummer
4. Fabrikat und Type des Fahrzeuges
5. Benennung des Ersatzteils: Wie in der Ersatzteilliste aufgeführt.
6. Ersatzteil-Nummer: Siehe Ersatzteilliste, Nummer ist größtenteils auch im Teil eingeschlagen.
7. Versandart: Post, Luftpost, Express, Fracht, Eilgut, Stückgut; fehlen Angaben, so geschieht der Versand nach unserem Ermessen.

} Angaben siehe Typenschild  
bzw. eingeschlagene Zahlen

## DELIVERY CONDITIONS FOR SPARE PARTS

In order to secure a correct and prompt delivery, all spare part orders should be compiled as follows:

1. Type
2. Serial-No.
3. Parts list No.
4. Trade mark and type of vehicle:
5. Denomination of spare part: according to the indication in the parts list.
6. Spare parts No.: see spare parts list, the number is very often engraved on the part.
7. Way of delivery: mail, air mail, express delivery, ordinary freight, express goods, cargo; if no indication is made, the transportation will be realized to our opinion.

} see indications on type  
identification plate  
resp. engraved part number

Telefonische oder telegraphische Bestellungen bitten wir schriftlich zu bestätigen.

We kindly ask you to confirm orders given by telephone call or telegramme.

Der Versand geschieht auf Gefahr des Käufers, auch dann, wenn die Ersatzteile nicht berechnet werden.

Even if the spare parts are free of charge the delivery will be to the buyers obligations.

Zahlungsbedingungen: Die Kosten für Ersatzteile werden durch Nachnahme erhoben.

Terms : Cash on delivery

## CONDITIONS DE LIVRAISON POUR LES PIÈCES DE RECHANGE

Afin de vous assurer une prompte et correcte livraison, les commandes des pièces de rechange doivent être rédigées dans la façon suivante:

1. Type
2. No. de la série
3. No. de la liste de pièces
4. Marque et type de véhicule
5. Dénomination de la pièce de rechange come indiquéê sur la liste des pièces de rechange.
6. No. de la pièce : v. liste des pièces de rechange, la plupart du temps, le nombre vient aussi poinçonné sur la pièce.
7. Mode d'expédition : ar poste, poste aérienne, express, en grande vitesse, en colis; où il n'y a pas des spécifications, l'expédition sera effectuée à notre choix.

} v. les indications sur la plaque  
de type, resp. les chiffres poinçonnées

Nous vous prions de nous confirmer par écrit les commandes données par téléphone ou télégramme.

La marchandise sera toujours expédiée aux risques de l'acheteur, même dans le cas où les de rechange ne viennent pas facturées.

Conditions de payment: contre remboursement.

INHALTSVERZEICHNISTABLE OF CONTENTSTABLE DES METIERESGRUPPE  
GROUP  
GROUPESEITE  
PAGE  
PAGEABTRIEB RECHTS U. LINKS,  
BREMSEFINAL DRIVE R.H. AND L.H.,  
BRAKE

SORTIE DROITE, GAUCHE, FREIN

111

58

ANTRIEBSWELLE

INPUT SHAFT

ARBRE DE ENTREE

102

35

AUSGLEICHGETRIEBE

DIFFERENTIAL

DIFFERENTIEL

109

51

AUSGLEICHSPERRE

DIFF.INTERLOCK

BLOCAGE DIFFERENTIEL

138

55

EINGANGSWELLE

INPUT SHAFT

ARBRE DE ENTREE

149

3

FESTSTELLBREMSBETAETIGUNG

PARKING-BRAKE ACTUATION

COMMANDE FREIN MAIN

125

67

GETRIEBEGEHAUSE

GEARBOX HOUSING

CARTER DE BOITE

101

5

GRUPPENGETRIEBE

RANGE GEAR

BOITE VIT A GAMMES

115

29

HAUPTWELLE

MAIN SHAFT

ARBRE PRINCIPAL

104

37

KRIECHGANG - VERSCHLUSS-  
TEILELOCKING COMPONENTS OF THE  
CREEP SPEED RANGEVITESSE LENTE - PIECES DE  
FERMETURE

114

7

KRIECHGANG

CREEP SPEED RANGE

VITESSE LENTE

114

81

OELVERSORGUNG

OIL DISTRIBUTOR

DISTRIBUTEUR HUILE

136

21

PUMPENANTRIEB - VER-  
SCHLUSSTEILEPUMP DRIVE ASSEMBLY -  
LOCKING COMPONENTSENTRAINEMENT DE LA POMPE -  
PIECES DE FERMETURE

122

9

RUECKLAUF

RETURN

RETOUR

105

33

SCHALTUNG

GEARSHIFT SYST

CHANGEMT. VIT.

106

12

SUPERKRIECHGANG

SUPER CREEP SPEED RANGE

VITESSE TRES LENTE

114

85

VORDERRADANTRIEB

FRONT - WHEEL DRIVE

COMMANDE ROUES AV.

146

70

VORGELEGEWELLE

LAYSHAFT

ARBRE INTERMEDIAIRE.

103

25

ZAPFWELLE

PTO - SHAFT

PRISE DE FORCE

110

43

ZAPFWELLENSCHALTUNG

PTO - SHIFT CONTROL

COMMANDE VIT. PTD.

142

47

Gruppe  
Group  
Groupe

2052 149

EING. U. HOHLWELLE  
INPUT/HOLLOW SHAFT  
ARBRE D ENTREE/CREUX

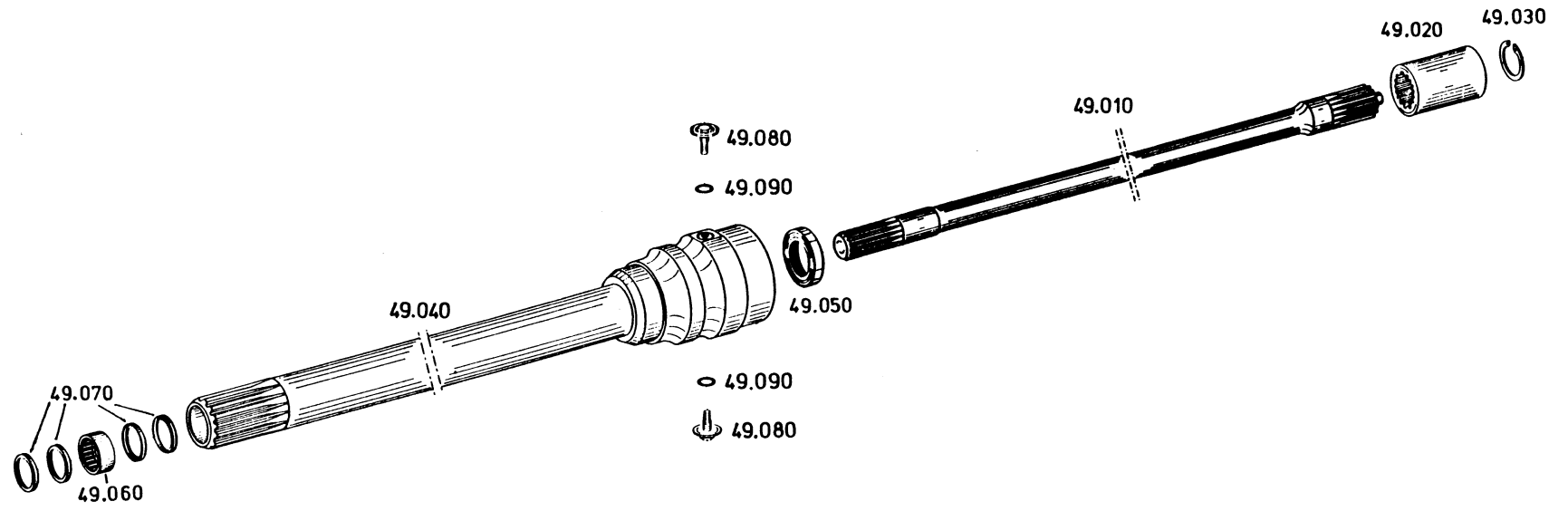

Die Abbildungen sind für die Ausführung nicht verbindlich  
Illustrations are not binding for the design  
Les illustrations ne sont pas obligatoires pour l'exécution

<b>Gruppe</b> 2052 149	EINGANSWELLE	<b>Stückzahl nach Ausführung / Quantity per model / Nombre par modèle</b>
<b>Group</b>	INPUT SHAFT	
<b>Groupe</b>	ARBRE D'ENTREE	

2071 060

21.11.86

Bild Nr. Fig. No. Fig. No.	Teilnummer Partnumber No. de pièce	Benennung	Description	Désignation	Änderung Modification Modification	alle									
						all tous	023	024							
010	2052 349 164	EINGANGSWELLE	INPUT SHAFT	ARBRE D'ENTREE				1							
	2052 349 210	EINGANGSWELLE	INPUT SHAFT	ARBRE D'ENTREE			1								
020	2052 349 151	PROFILBUCHSE	PROFILE BUSHING	DOUILLE PROFILEE			1	1							
030	0630 532 139 31x1,2 DIN 472	SICHERUNGSRING	CIRCLIP	CIRCLIP			1	1							
040	2052 249 118	HOHLWELLE KPL. NUR KOMPL. LIEFER- BAR MIT BILD NR. 060 UND 070 KPL.- NR. 2052 298 923	QUILL SHAFT ASS. ONLY AVAILABLE AS A COMPLETE UNIT WITH FIR. NO. 060 AND 070 NO. 2052 298 923	ENSEMBLE ARBRE CREUZ A LIVRER SEULEMENT EN ENSEMBLE AVEC FIG. NO. 060 ET 070 EN- SEMBLE NO. 2052 298 923				1							
	2052 249 131	HOHLWELLE KPL. NUR KOMPL. LIEFER- BAR MIT BILD NR. 060 UND 070 KPL. NR. 2052 298 980	QUILL SHAFT ASS. ONLY AVAILABLE AS A COMPLETE UNIT WITH FIR. NO. 060 AND 070 NO. 2052 298 980	ENSEMBLE ARBRE CREUZ A LIVRER SEULEMENT EN ENSEMBLE AVEC FIG. NO. 060 ET 070 EN- SEMBLE NO. 2052 298 980			1								
050	0734 300 109	WELLENDICHTRING	SHAFT SEAL	BAGUE ETANCHEITE			1	1							
060	0635 303 129 HK 3020 SM 21	NADELHUELSE	NEEDLE BUSH	DOUILLE AIGUILLES			1	1							
070	4614 302 004	DECKSCHEIBE	COVER SHIM	DISQUE RECOUVREMENT			4	4							
080	2052 349 181	SICHERUNGSSCHRAUBE	LOCK SCREW	VIS SECURITE			2	2							
090	0634 313 035 8x2,5	O-RING	O-SEAL	BAGUE TORIQUE			2	2							

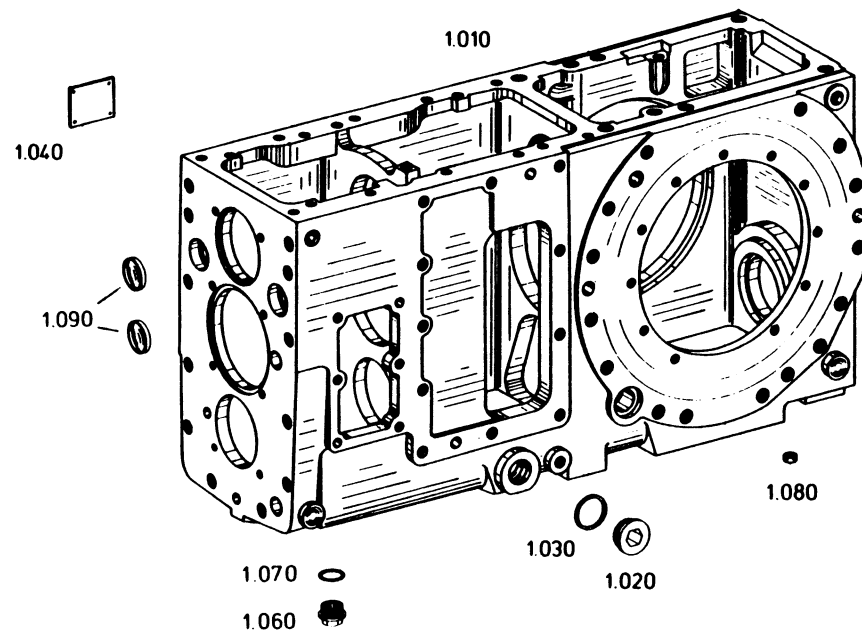

Die Abbildungen sind für die Ausführung nicht verbindlich  
Illustrations are not binding for the design  
Les illustrations ne sont pas obligatoires pour l'exécution

Gruppe 2052 101 GETR.GEHAUSE  
 Group GEARBOX HOUSING  
 Groupe CARTER DE BOITE

Stückzahl nach Ausführung / Quantity per model /  
 Nombre par modèle  
 2071 060 21.11.86

Bild Nr. Fig. No. Fig. No.	Teilnummer Partnumber No. de pièce	Benennung	Description	Désignation	Änderung Modification Modification	Stückzahl nach Ausführung / Quantity per model / Nombre par modèle														
						alle all tous	023	024												
010	2052 301 035	GETR.GEHAUSE	GEARBOX HOUSING	CARTER DE BOITE			1	1												
020	0636 302 009 M 33X2 DIN 908	VERSCHL.SCHR.	SCREW PLUG	VIS FERMETUPE			2	2												
030	0634 801 227 A 33X39 DIN 7603	DICHTRING	SEALING RING	BAGUE ETANCH.			2	2												
040	0730 365 069	BAUMUSTERSCHILD	TYPE PLATE	PLAQUE SIGNALET			1	1												
	0631 311 009 3X5 DIN 1476	KERBNAGEL	GROOVED STUD	RIVET CANNELE			4	4												
060	0015 300 160	VERSCHL.SCHP.	SCREW PLUG	VIS FERMETURE			1	1												
070	0634 801 200 A 24X29 DIN 7603	DICHTRING	SEALING RING	BAGUE ETANCH.			1	1												
080	0630 361 038 12 DIN 443	VERSCHL.DECKEL	SEALING CAP	COUVERCLE			2	2												
090	0630 361 046 42 DIN 443	VERSCHL.DECKEL	SEALING CAP	COUVERCLE			2	2												

Gruppe 2052 114 KRIECHGANG-VERSCHLUSSTEILE  
Group LOCKING COMPONENTS OF THE CREEP SPEED RANGE  
Groupe VITESSE LENTE-PIECES DE FERMETURE

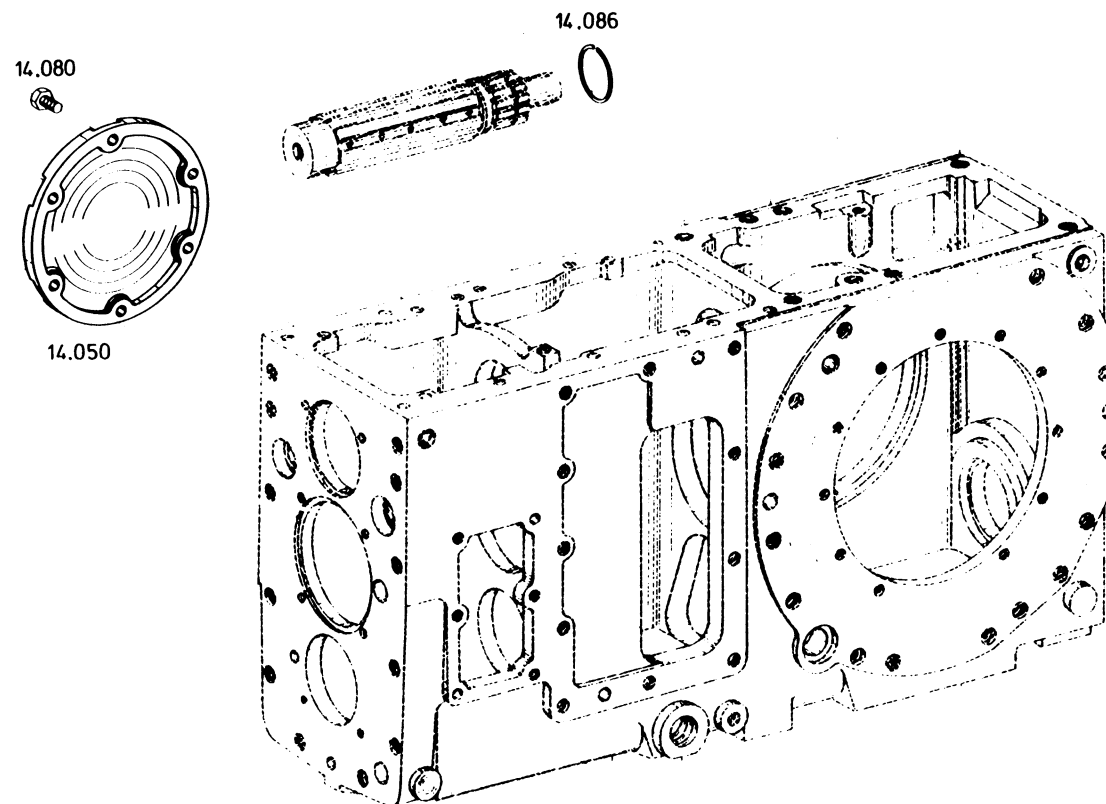

Die Abbildungen sind für die Ausführung nicht verbindlich  
Illustrations are not binding for the design  
Les illustrations ne sont pas obligatoires pour l'exécution



Gruppe 2052 114 KRIECHGANG-VERSCHLUSSTEILE  
 Group LOCKING COMPONENTS OF THE CREEP SPEED RANGE  
 Groupe VITESSE LENTE-PIECES DE FERMETURE

Stückzahl nach Ausführung / Quantity per model /  
 Nombre par modèle  
 2071 060 21.11.86

Bild Nr. Fig. No. Fig. No.	Teilnummer Partnumber No. de pièce	Benennung	Description	Désignation	Änderung Modification Modification	alle all tous	023	024							
050	2052 314 001	VERSCHL.DECKEL	SEALING CAP	COUVERCLE			1	1							
080	0636 015 114 M 10X22 DIN 933 A. 8	6KT.SCHRAUBE	HEXAGON SCREW	VIS HEXAGONALE			6	6							
086	0630 513 157 SW 48	SPRENGRING	SNAP RING	CIRCLIP			1	1							

Gruppe 2052 122  
Group  
Groupe

PUMPENANTRIEB-VERSCHLUSSTEILE  
PUMPE DRIVE ASSEMBLY-LOCKING COMPONENTS  
ENTRAINEMENT DE LA POMPE-PIECES DE FERMETURE

22.040

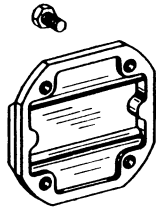

22.030

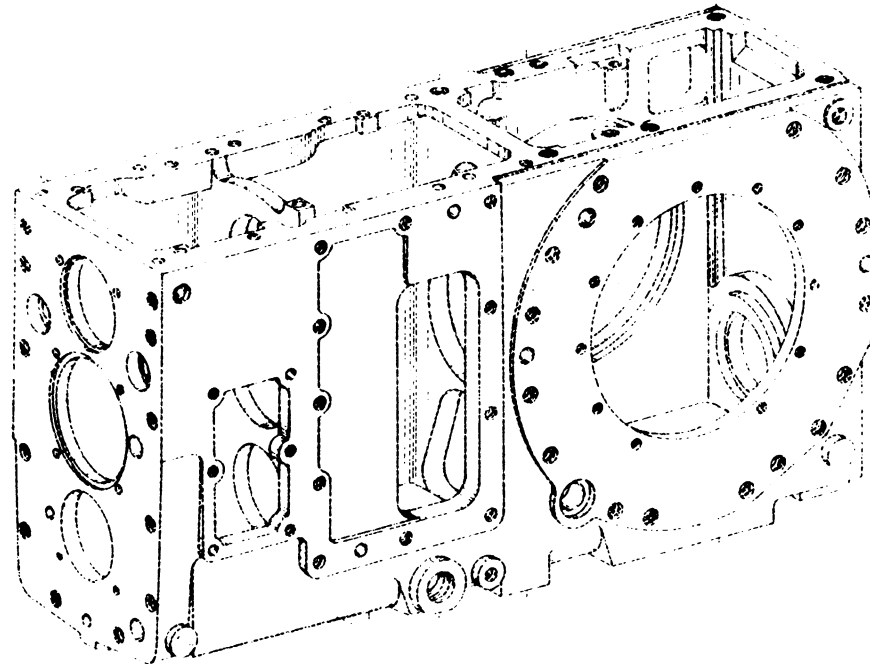

Die Abbildungen sind für die Ausführung nicht verbindlich  
Illustrations are not binding for the design  
Les illustrations ne sont pas obligatoires pour l'exécution

Gruppe 2052 122  
 Group  
 Groupe

PUMPENANTRIEB-VERSCHLUSSTEILE  
 PUMPE DRIVE ASSEMBLY-LOCKING COMPONENTS  
 ENTRAINEMENT DE LA POMPE-PIECES DE FERMETURE

Stückzahl nach Ausführung / Quantity per model /  
 Nombre par modèle  
 2071 060 21.11.86

Bild Nr. Fig. No. Fig. No.	Teilnummer Partnumber No. de pièce	Benennung	Description	Désignation	Änderung Modification Modification	alle											
						all	tous										
						023	024										
030	2052 322 013	VERSCHL.DECKEL	SEALING CAP	COUVERCLE			1	1									
040	0636 016 009 M 12X25 DIN 933 8.8	6KT.SCHRAURE	HEXAGON SCREW	VIS HEXAGONALE			4	4									

Gruppe 2052 106 SCHALTUNG  
Group GEARSHIFT SYST.  
Groupe CHANGEMT.VIT.

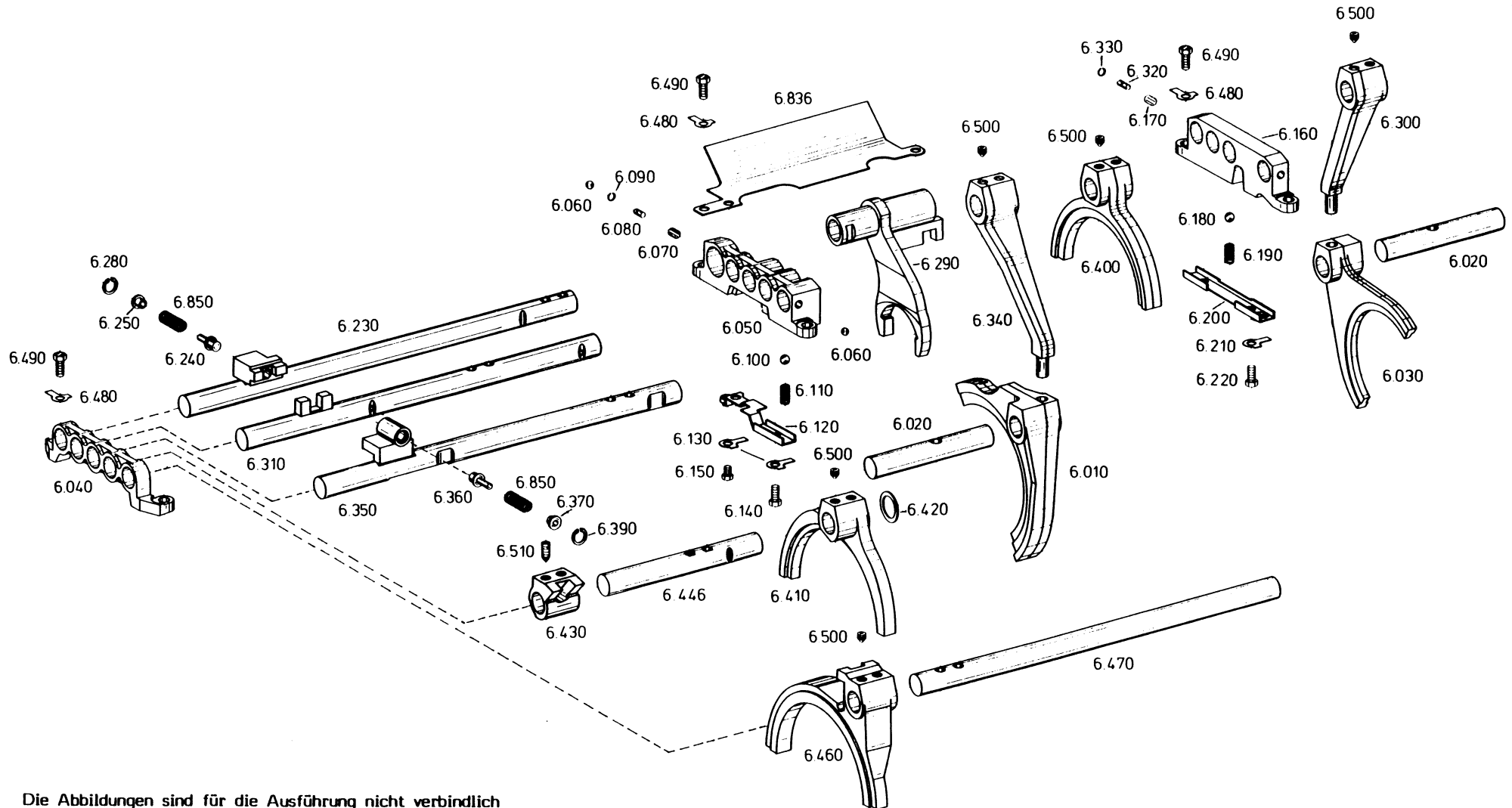

Die Abbildungen sind für die Ausführung nicht verbindlich  
Illustrations are not binding for the design  
Les illustrations ne sont pas obligatoires pour l'exécution

Gruppe 2052 106 SCHALTUNG  
 Group GEARSHIFT SYST.  
 Groupe CHANGEMT.VIT.

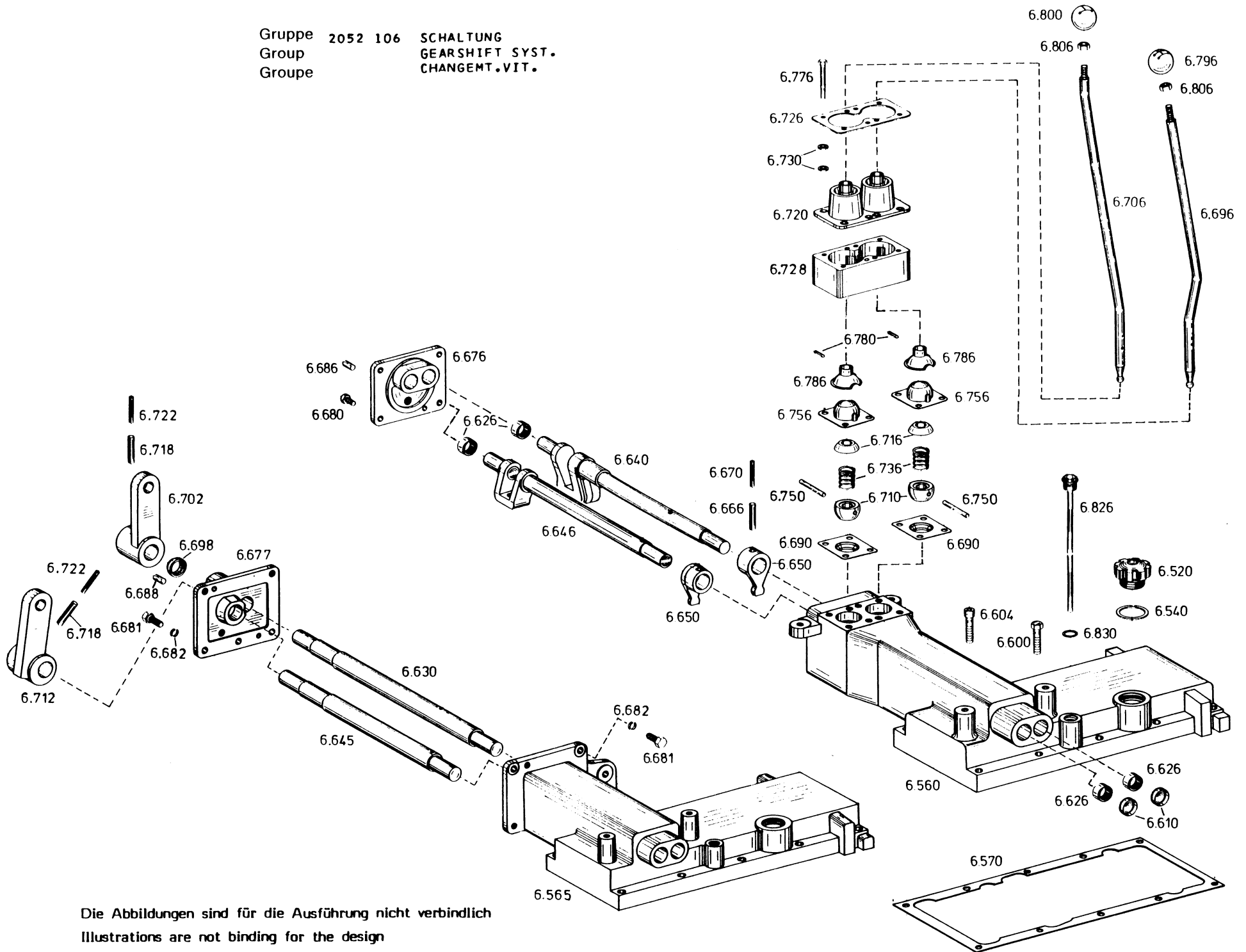

Die Abbildungen sind für die Ausführung nicht verbindlich  
 Illustrations are not binding for the design  
 Les illustrations ne sont pas obligatoires pour l'exécution

Gruppe 2052 106 SCHALTUNG  
 Group GEARSHIFT SYST.  
 Groupe CHANGEMT.VIT.

Stückzahl nach Ausführung / Quantity per model /

Nombre par modèle

2071 060

21.11.86

Bild Nr. Fig. No. Fig. No.	Teilnummer Partnumber No. de pièce	Benennung	Description	Désignation	Änderung Modification Modification	alle all tous	023	024								
010	2052 306 359 3.+4.GG.	SCHALTGABEL	GEAR SHIFT FORK	FOURCH.PASS.VIT			1	1								
020	2052 306 047	LAGERBOLZEN	BEARING BOLT	BOUL.DE PALIER			2	2								
030	2052 306 035 1.+2.GG	SCHALTGABEL	GEAR SHIFT FORK	FOURCH.PASS.VIT			1	1								
040	2052 306 042 VORN	LAGERBUEGEL	BEARING BRACKET	ETRIER PALIER			1	1								
050	2052 306 301 MITTE	LAGERBUEGEL	BEARING BRACKET	ETRIER PALIER			1	1								
060	0635 460 015	KUGEL	BALL	BILLE			3	3								
070	0731 208 019	SPERRSTIFT	LOCKING PIN	GOUP. D'ARRET			2	2								
080	0731 306 028	SPERRSTIFT	LOCKING PIN	GOUP. D'ARRET			1	1								
090	0630 505 002 7 DIN 9045	SPRENGRING	SNAP RING	CIRCLIP			1	1								
100	0635 460 021	KUGEL	BALL	BILLE			3	3								
110	1203 306 092	DRUCKFEDER	COMPR.SPRING	RESSORT PRESS.			3	3								
120	2052 306 302	DECKBLECH	COVER SHEET	TOLE RECOUVREMT			1	1								
130	0630 603 005 8,4 DIN 463	SICHERUNGSBLECH	TAB WASHER	TOLE-FREIN			2	2								
140	0636 015 073 M 8X18 DIN 933 8.8	6KT.SCHRAUBE	HEXAGON SCREW	VIS HEXAGONALE			1	1								
150	0636 015 060 M 8X12 DIN 933 8.8	6KT.SCHRAUBE	HEXAGON SCREW	VIS HEXAGONALE			1	1								
160	2052 306 127 HINTEN	LAGERBUEGEL	BEARING BRACKET	ETRIER PALIER			1	1								
170	0731 208 019	SPERRSTIFT	LOCKING PIN	GOUP. D'ARRET			2	2								

Gruppe 2052 106 SCHALTUNG  
 Group GEARSHIFT SYST.  
 Groupe CHANGEMT.VIT.

Stückzahl nach Ausführung / Quantity per model /  
 Nombre par modèle  
 2071 060 21.11.86

Bild Nr. Fig. No. Fig. No.	Teilnummer Partnumber No. de pièce	Benennung	Description	Désignation	Änderung Modification Modification	alle											
						all	tous										
180	0635 460 021	KUGEL	BALL	BILLE			3	3									
190	1203 306 092	DRUCKFEDEP	COMPR.SP RING	RESSORT PRESS.			3	3									
200	2052 306 049	DECKBLECH	COVER SHEFT	TOLE RECOUVREMT			1	1									
210	0630 603 005 8,4 DIN 463	SICHERUNGSBLECH	TAB WASHER	TOLE-FREIN			2	2									
220	0636 015 073 M 8X18 DIN 933 8.8	6KT.SCHRAUBE	HEXAGON SCREW	VIS HEXAGONALE			2	2									
230	2052 206 242	SCHALTSCHIENE	GEAR SHIFT RAIL	GLISSIERE CDE			1	1									
240	2052 306 054	ANSCHLAGBOLZEN	STOP BOLT	AXE DE BUTEE			1	1									
250	2052 306 214	FUEHRUNGSHUELSE	GUIDE SLEEVE	DOUILLE GUIDAGE			1	1									
280	0630 502 003 15X1 DIN 472	SICHERUNGSP RING	RETAINING RING	JONC D'ARRET			1	1									
290	2052 214 082	SCHALTGABEL	GEAR SHIFT FORK	FOURCH.PASS.VIT			1	1									
300	2052 306 377	UMLENKHEBEL ANLAUFTEIL	RELAY LEVER INTRODUCTION DATE	LEVIER RENVOI MOMENT DE DEMARRAGE	21444		1	1									
	2052 306 056	UMLENKHEBEL AUSLAUFTEIL	RELAY LEVER TERMINATING DATE	LEVIER RENVOI MOMENT DE TERMNAISON	21444		1	1									
310	2052 206 257	SCHALTSCHIENE	GEAR SHIFT RAIL	GLISSIERE CDE			1	1									
320	0731 201 193	SPERPSTIFT	LOCKING PIN	GROUP. D'ARRET			1	1									
330	0630 505 002 7 DIN 9045	SPRENGRING	SNAP RING	CIRCLIP			1	1									
340	2052 306 060	UMLFNKHEBEL	RELAY LEVER	LEVIER RENVOI			1	1									
350	2052 206 239 5.+6.GG	SCHALTSCHIENE	GEAR SHIFT RAIL	GLISSIERE CDE			1	1									

Gruppe 2052 106 SCHALTUNG  
 Group GEARSHIFT SYST.  
 Groupe CHANGEMT.VIT.

Stückzahl nach Ausführung / Quantity per model /  
 Nombre par modèle

2071 060

21.11.86

Bild Nr. Fig. No. Fig. No.	Teilnummer Partnumber No. de pièce	Benennung	Description	Désignation	Änderung Modification Modification	alle all tous	023	024							
360	2052 306 054	ANSCHLAGBOLZEN	STOP BOLT	AXE DE BUTEE			1	1							
370	2052 306 214	FUEHRUNGSHUELSE	GUIDE SLEEVE	DOUILLE GUIDAGE			1	1							
390	0630 502 003 15X1 DIN 472	SICHERUNGSRING	RETAINING RING	JONC D'ARRET			1	1							
400	2052 306 038 5.+6.GG	SCHALTGABEL	GEAR SHIFT FORK	FOURCH.PASS.VIT			1	1							
410	2052 306 299 R-GRUPPE	SCHALTGABEL	GEAR SHIFT FORK	FOURCH.PASS.VIT			1	1							
420		PASS-SCHEIBE WAHLWEISE	SHIM RING OPTIONAL	RONDELLE AJUST. EN OPTION			1	1							
	0630 000 120 22X30X1 DIN 988	PASS-SCHEIBE	SHIM RING	RONDELLE AJUST.			1	1							
	0630 000 165 22X30X1,5 DIN 988	PASS-SCHEIBE	SHIM RING	RONDELLE AJUST.			1	1							
	0630 100 002 S 22X30X2 DIN 988	STUFTZSCHEIBE	SUPPORT SHIM	RONDELLE APPUI			1	1							
	0630 000 122 22X30X0,2 DIN 988	PASS-SCHEIBE	SHIM RING	RONDELLE AJUST.			1	1							
	0630 000 121 22X30X0,5 DIN 988	PASS-SCHEIBE	SHIM RING	RONDELLE AJUST.			1	1							
	0630 000 168 22X30X1,2 DIN 988	PASS-SCHEIBE	SHIM RING	RONDELLE AJUST.			1	1							
	0630 000 166 22X30X1,4 DIN 988	PASS-SCHEIBE	SHIM RING	RONDELLE AJUST.			1	1							
430	2052 306 300	MITNEHMER	DRIVER	ENTRAINEUR			1	1							
446	2052 306 304 R-GRUPPE	SCHALTSCHIENE	GEAR SHIFT RAIL	GLISSIERE CDE			1	1							
460	2052 306 298	SCHALTGABEL	GEAR SHIFT FORK	FOURCH.PASS.VIT			1	1							
470	2052 306 323	SCHALTSCHIENE	GEAR SHIFT RAIL	GLISSIERE CDE			1	1							



Gruppe 2052 106 SCHALTUNG  
 Group GEARSHIFT SYST.  
 Groupe CHANGEMT.VIT.

Stückzahl nach Ausführung / Quantity per model /  
 Nombre par modèle  
 2071 060 21.11.86

Bild Nr. Fig. No. Fig. No.	Teilnummer Partnumber No. de pièce	Benennung	Description	Désignation	Änderung Modification Modification	Stückzahl nach Ausführung / Quantity per model / Nombre par modèle														
						alle all tous	023	024												
480	0630 603 007 10,5 DIN 463	SICHERUNGSBLECH	TAB WASHER	TOLE-FREIN				6	6											
490	0636 015 120 M 10X25 DIN 933 8.8	6KT.SCHRAUBE	HEXAGON SCREW	VIS HEXAGONALE				6	6											
500	1238 306 065	GEWINDESTIFT	SET SCREW	GOUJON FILETE				10	10											
510	0731 611 019	GEWINDESTIFT	SET SCREW	GOUJON FILETE				2	2											
520	2052 206 007	ENTLUEFTER	BREATHER	RENIFLARD				1	1											
540	0634 801 215 A 42X40 DIN 7603	DICHTRING	SEALING RING	BAGUE ETANCH.				1	1											
560	0501 307 307	GEHAUSEDECKEL	HOUSING COVER	COUVERCLE CART.						1										
565	0501 310 528	GEHAUSEDECKEL	HOUSING COVER	COUVERCLE CAPT.				1												
570	2052 306 285	DICHTUNG	GASKET	JOINT				1	1											
600	0636 010 156 M 10X40 DIN 931 8.8	6KT.SCHPAUBE	HEXAGON SCREW	VIS HEXAGONALE				10	9											
604	0636 101 054 M 10X40 DIN 912 8.8	ZYL.SCHPAUBE	CAP SCREW	VIS TETE CYL.						1										
610	0630 361 035 28 DIN 443	VERSCHL.DECKEL	SEALING CAP	COUVERCLE				2	2											
626	0735 298 002	NADELHUELSE	NEEDLE SLEEVE	DOUILLE A AIG.				4	4											

Gruppe 2052 106 SCHALTUNG  
 Group GEARSHIFT SYST.  
 Groupe CHANGEMT.VIT.

Stückzahl nach Ausführung / Quantity per model /  
 Nombre par modèle  
 2071 060 21.11.86

Bild Nr. Fig. No. Fig. No.	Teilnummer Partnumber No. de pièce	Benennung	Description	Désignation	Änderung Modification Modification	alle all tous	023	024							
640	0501 206 421	SCHALTWELLE	G.SHIFT SHAFT	ARBRE CDE VIT.				1							
630	0501 310 530	SCHALTWELLE	G.SHIFT SHAFT	ARBRE CDE VIT.			1								
645	0501 310 532	SCHALTWELLE	G.SHIFT SHAFT	ARBRE CDE VIT.			1								
646	2052 206 236	SCHALTWELLE	G.SHIFT SHAFT	ARBRE CDE VIT.				1							
650	2052 306 294	SCHALTFINGER	G.SHIFT FINGER	DOIGT DE CDE			2	2							
666	0631 328 546 SG 8X40	SPANNSTIFT	SLOT.PIN	GOUPILLE ELAST.			2	2							
670	0631 329 057 5X40 DIN 1481	SPANNSTIFT	SLOT.PIN	GOUPILLE ELAST.			2	2							
676	0501 306 126	LAGERDECKEL	BEARING COVER	COUVERCLE				1							
677	0501 310 529	LAGERDECKEL	BEARING COVER	COUVERCLE			1								
680	0636 015 077 M 8X20 DIN 933 8.8	6KT.SCHRAUBE	HEXAGON SCREW	VIS HEXAGONALE				4							
681	0636 015 127 M 10X30 DIN 933 8.8	6KT.SCHRAUBE	HEXAGON SCREW	VIS HEXAGONALE			5								
682	0630 301 011 A 10 DIN 127	FEDERRING	SPRING WASHER	BAGUE ELASTIQUE			5								
686	0631 329 079 8X20 DIN 1481	SPANNSTIFT	SLOT.PIN	GOUPILLE ELAST.				1							
688	0631 329 080 8X24 DIN 1481	SPANNSTIFT	SLOT.PIN	GOUPILLE ELAST.			2								
690	2052 306 246	LAGERSCHALE	BEARING SHELL	COQU.COUSSINET				2							

Gruppe 2052 106 SCHALTUNG  
 Group GEARSHIFT SYST.  
 Groupe CHANGEMT.VIT.

Stückzahl nach Ausführung / Quantity per model /  
 Nombre par modèle  
 2071 060 21.11.86

Bild Nr. Fig. No. Fig. No.	Teilnummer Partnumber No. de pièce	Benennung	Description	Désignation	Änderung Modification Modification	alle all tous	Stückzahl nach Ausführung / Quantity per model / Nombre par modèle													
							023	024												
696	0501 310 691	SCHALTHEBEL	G.SHIFT LEVER	LEVIER CDE VIT.				1												
698	0501 310 548	ABSTREIFER	ROD WIPER	PACLEUR			2													
702	0501 310 531	HEBEL	LEVER	LEVIER			1													
706	0501 310 692	SCHALTHEBEL	G.SHIFT LEVER	LEVIER CDE VIT.				1												
710	2052 306 027	SCHALTKUGEL	GEAR SHIFT BALL	SPHERE COMMANDE				2												
712	0501 310 533	HEBEL	LEVER	LEVIER			1													
716	2052 306 028	SCHALTKUGEL	GEAR SHIFT BALL	SPHERE COMMANDE				2												
718	0631 329 072 6X40 DIN 1481	SPANNSTIFT	SLOT.PIN	GOUPILLE ELAST.			4													
720	0501 307 233	DOPPELFALTENBA.						1												
722	0631 329 145 3,5X40 DIN 1481	SPANNSTIFT	SLOT.PIN	GOUPILLE ELAST.			4													
726	0501 307 234	BRILLE						1												
728	0501 310 690	ZWISCHENSTUECK	INTERM.PIECE	PIECE INTERM.				1												
730	0501 307 235	DISTANZRING	SPACER RING	BAGUE ENTRET.				16												
736	0732 040 256	DRUCKFEDER	COMPR.SPRING	RESSORT PRESS.				2												
750	2056 306 013	KERBSTIFT	GROOVED PIN	GOUP.CANNELEE				2												
756	2052 306 245	SCHALTKAPPE	GEAR SHIFT CAP	CAPUCHON COMM.				2												
776	0636 010 103 M 8X70 DIN 931 9.8	6KT.SCHRAUBE	HEXAGON SCREW	VIS HEXAGONALE				8												
780	0631 329 136 4X22 DIN 1481	SPANNSTIFT	SLOT.PIN	GOUPILLE ELAST.				2												

Gruppe 2052 106 SCHALTUNG  
 Group GEARSHIFT SYST.  
 Groupe CHANGEMT.VIT.

Stückzahl nach Ausführung / Quantity per model /  
 Nombre par modèle  
 2071 060 21.11.86

Bild Nr. Fig. No. Fig. No.	Teilnummer Partnumber No. de pièce	Benennung	Description	Désignation	Anderung Modification Modification	alle all tous	023	024							
786	2056 306 115	SCHUTZKAPPE	PROTECTING CAP	CAPUCH.PROTECT.				2							
796	0632 329 035 KK ZFN 29 SCHWARZ	GRIFF	HANDLE	POIGNEE				1							
800	0632 329 053 C 1 ZFN 29 SCHWARZ	GRIFF	HANDLE	POIGNEE				1							
806	0637 009 008 M 10 DIN 936	6KT.MUTTER	HEXAGON NUT	ECROU HEXAGONAL				2							
826	2052 206 004	DELMESSSTAB	OIL DIPSTICK	JAUGE D'HUILE			1	1							
830	0634 801 057 A 18X22 DIN 7603	DICHTRING	SEALING RING	BAGUE ETANCH.			1	1							
836	2052 306 305	SPRITZBLECH	SPLASH GUARD	DEFLECTEUR			1	1							
850	0732 040 439	DRUCKFEDER	COMPR.SPRING	RESSORT PRESS.			2	2							



Gruppe 2052 136  
Group  
Groupe

DELVERSORGUNG  
OIL SUPPLY  
ALIMENT. HUILE

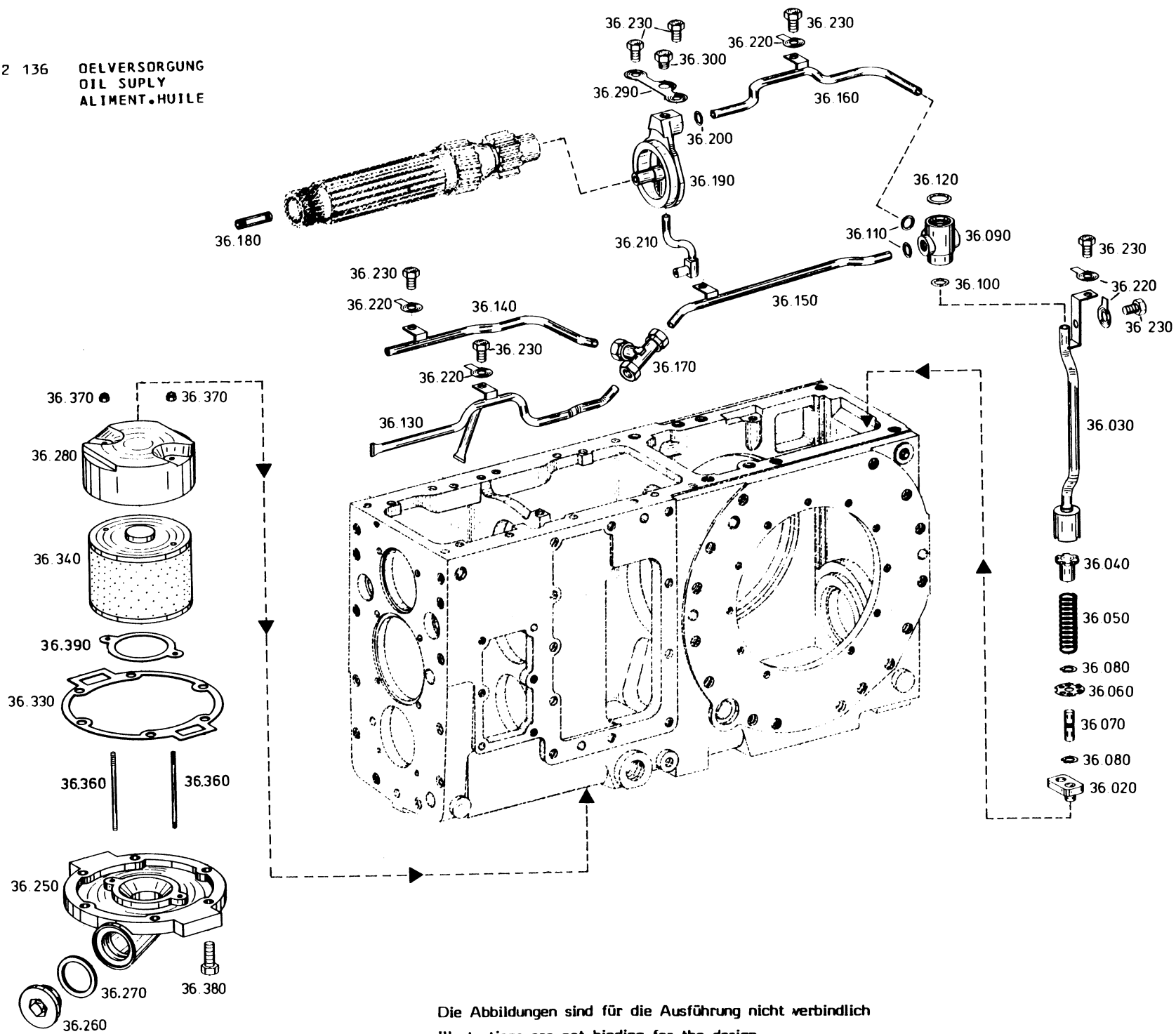

Die Abbildungen sind für die Ausführung nicht verbindlich  
Illustrations are not binding for the design  
Les illustrations ne sont pas obligatoires pour l'exécution

Gruppe 2052 136 OELVERSORGUNG  
 Group OIL SUPPLY  
 Groupe ALIMENT.HUILE

Stückzahl nach Ausführung / Quantity per model /  
 Nombre par modèle  
 2071 060 21.11.86

Bild Nr. Fig. No. Fig. No.	Teilnummer Partnumber No. de pièce	Benennung	Description	Désignation	Änderung Modification Modification	alle all tous	023	024							
020	2052 236 084	HALTEBLECH	FIXING PLATE	TOLE SUPPORT			1	1							
030	2052 236 083	ROHR	PIPE	TUBE			1	1							
040	2052 336 130	SCHEIBE	WASHER	RONDELLE			1	1							
050	1210 307 032	DRUCKFEDER	COMPR.SP RING	RESSORT PRESS.			1	1							
060	2052 336 128	VENTILDECKEL	VALVE COVER	COUV.DE VALVE			1	1							
070	2052 336 129	FUEHRUNGSBOLZEN	GUIDE BOLT	AXE GUIDE			1	1							
080	0630 501 007 11X1 DIN 471	SICHERUNGSRING	RETAINING RING	JONG D'ARRET			2	2							
090	2052 336 108	VERTEILERSTUECK	DISTR.PIECE	PIECE DISTRIB.			1	1							
100	0634 306 015 15,3X2,4 ZFN 744	O-RING	O-RING	JOINT TORIQUE			1	1							
110	0634 306 011 12,3X2,4 ZFN 744	O-RING	O-RING	JOINT TORIQUE			2	2							
120	0634 306 022 22,3X2,4 ZFN 744	O-RING	O-RING	JOINT TORIQUE			1	1							
130	2052 236 068	ROHR	PIPE	TUBE			1	1							
140	2052 236 090	ROHR	PIPE	TUBE			1	1							
150	2052 236 047	ROHR	PIPE	TUBE			1	1							
160	2052 236 092	ROHR	PIPE	TUBE			1	1							

Gruppe 2052 136 OELVERSORGUNG  
 Group OIL SUPPLY  
 Groupe ALIMENT.HUILE

Stückzahl nach Ausführung / Quantity per model /  
 Nombre par modèle

2071 060

21.11.86

Bild Nr. Fig. No. Fig. No.	Teilnummer Partnumber No. de pièce	Benennung	Description	Désignation	Änderung Modification Modification	alle all tous	023	024							
170	0637 880 050 QL 12 DIN 2353	VERSCHRAUBUNG	PIPE UNION	RACCORD A VIS			1	1							
180	2052 336 058	ROHR	PIPE	TUBE			1	1							
190	2052 336 147	ANSCHLUSS-STUECK	CONN.PART	RACCORD			1	1							
200	0634 306 011 12,3 x 2,4 ZFN 744	O-RING	O-RING	JOINT TORIQUE			1	1							
210	2052 236 088	OELZUFUEHRUNG	OIL FEEDER	AMENEE D'HUILE			1	1							
220	0630 601 006 10,5 DIN 93	SICHERUNGSBLECH	TAB WASHER	TOLE-FREIN			5	5							
230	0636 015 270 M 10 x 16 DIN 933 8.8	6KT.SCHRAUBE	HEXAGON SCREW	VIS HEXAGONALE			7	7							
250- 270	2052 236 075	FILTERDECKEL KPL. BESTEHEND AUS:	FILTER COVER ASS. CONSISTING OF:	COUVERC.FILTRE COMPL. COMPOSE DE:			1	1							
250	2052 336 109	DECKEL	COVER	COUVERCLE			1	1							
260	0636 302 043 R1 1 1/4" DIN 908	VERSCHLUSS-SCHRAUBE	SCREW PLUG	BOUCHON FILETE			1	1							
270	0634 801 215 A 42x49 DIN 7603	DICHTRING	SEAL RING	RONDELLE D'ETANCHEITE			1	1							
280	2052 336 152	DECKEL	COVER	COUVERCLE			1	1							
290	2052 336 149	SICHERUNGSBLECH	TAB WASHER	TOLE-FREIN			1	1							
300	0736 010 114	SCHRAUBE	SCREW	VIS			1	1							
330	2052 336 067	DICHTUNG	GASKET	JOINT			1	1							
340	2052 236 074	SAUGFILTER KPL. MIT BILD NR. 36-390	SUCTION FILTER CPL. WITH FIGURE NO 36 - 390	FILTRE D'ASPIR. COMPL AVEC FIGURE NO. 36 - 390			1	1							
360	0636 610 195 M 5x95 DIN 939 8.8	STIFTSCHRAUBE	STUD	GOUJON			2	2							



Gruppe 2052 136 OELVERSORGUNG  
 Group OIL SUPPLY  
 Groupe ALIMENT.HUILE

Stückzahl nach Ausführung / Quantity per model /  
 Nombre par modèle  
 2071 060 21.11.86

Bild Nr. Fig. No. Fig. No.	Teilnummer Partnumber No. de pièce	Benennung	Description	Désignation	Änderung Modification Modification	alle	023	024							
						all	tous								
370	0637 011 547 M 5	SICHERGS.MUTTER	LOCKING NUT	ECROU- FREIN			2	2							
380	0636 015 120 M 10X25 DIN 933 8.8	6KT.SCHRAURE	HEXAGON SCREW	VIS HEXAGONALE			6	6							
390	0501 303 920	DICHTRING	SEAL RING	RONDELLE D'ETANCHEITE			1	1							

Gruppe 2052 103 VORGELEGEWELLE  
Group LAYSHAFT  
Groupe ARBRE INTERM.

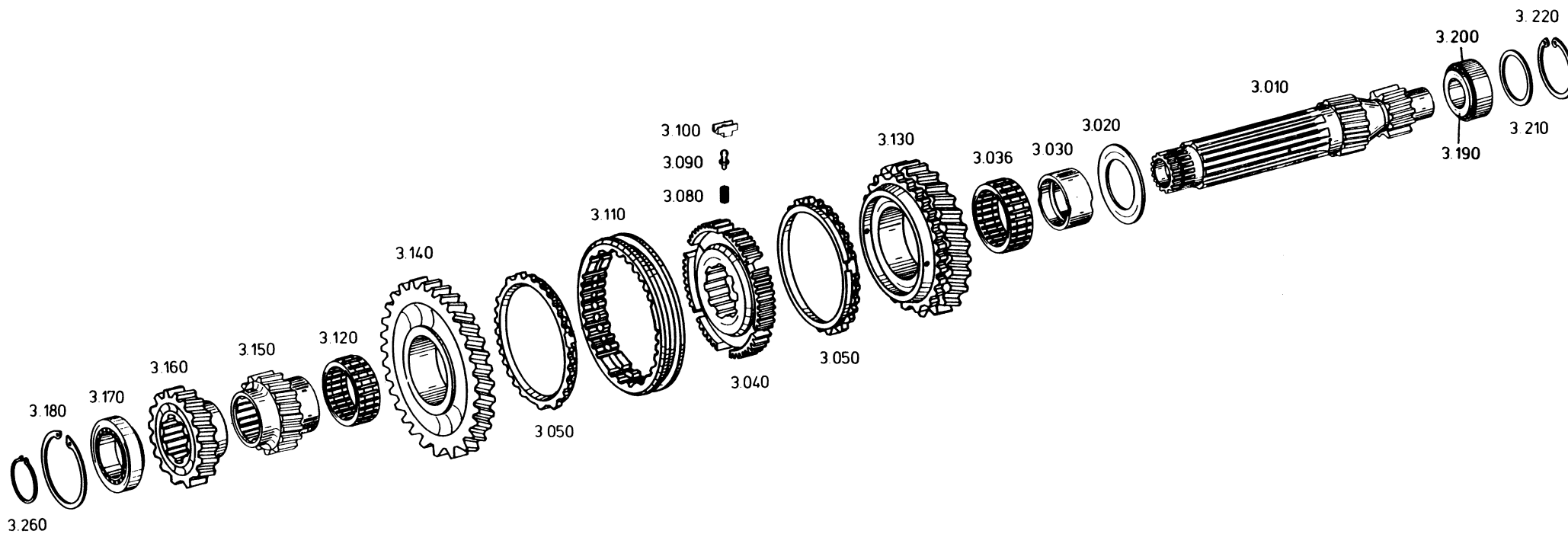

Die Abbildungen sind für die Ausführung nicht verbindlich  
Illustrations are not binding for the design  
Les illustrations ne sont pas obligatoires pour l'exécution

Gruppe 2052 103 VORGELEGEWELLE  
 Group LAYSHAFT  
 Groupe ARBRE INTERM.

Stückzahl nach Ausführung / Quantity per model /  
 Nombre par modèle  
 2071 060 21.11.86

Bild Nr. Fig. No. Fig. No.	Teilnummer Partnumber No. de pièce	Benennung	Description	Désignation	Änderung Modification Modification	alle all tous												
						023	024											
010	2052 203 189 7=20/12-	VORGELEGEWELLE	LAYSHAFT	ARBRE INTERM.			1	1										
020	0730 103 084	ANLAUFSCHLEIFE	THRUST WASHER	RONDELLE BUTEE			1	1										
030	0730 161 283	LAUFBUCHSE	BUSH	DOUILLE			1	1										
036	0750 115 081	NADELKAEFIG	NEEDLE CAGE	CAGE A AIG.			1	1										
040	2052 303 161 5.+6.GG	SYNCHRONKOEPPER	SYNCHRO.BODY	MOYEU SYNCHRON.			1	1										
050	2052 304 311	SYNCHRONRING	SYNCHRO.RING	RAGUE SYNCHRO.			2	2										
080	0732 040 409	DRUCKFEDER	COMPRESSING	RESSORT PRESS.			3	3										
090	1249 304 323	KUGELBOLZEN	BALL PIN	BOULON A ROTULE			3	3										
100	2052 304 360	DRUCKSTUECK	PRESSURE PIECE	POUSSOIR			3	3										
110	1238 304 357	SCHIEBEMUFFE	SLIDING SLEEVE	MANCHON			1	1										
120	0750 115 080	NADELKAEFIG	NEEDLE CAGE	CAGE A AIG.			1	1										
130	2052 203 080	STIRNRAD 5.G.	INTRODUCTION DATE	MOMENT DE DEMARRAGE	22481		1	1										
	0899 201 309	ANLAUFTEIL	SPUR GEAR	PIGNON CYLINDR.	22481		1	1										
		AUSLAUFTEIL	TERMINATING DATE	MOMENT DE TERMINATION														
140	2052 303 200	STIRNRAD 6.G.	INTRODUCTION DATE	MOMENT DE DEMARRAGE	22481		1	1										
	0899 308 396	ANLAUFTEIL	SPUR GEAR	PIGNON CYLINDR.	22481		1	1										
		AUSLAUFTEIL	TERMINATING DATE	MOMENT DE TERMINATION														
150	2052 303 160	STIRNRAD	SPUR GEAR	PIGNON CYLINDR.			1	1										
160	2052 303 156	STIRNRAD 4.G.	SPUR GEAR	PIGNON CYL.4E			1	1										
170	0635 371 033	ROLLENLAGER	ROLLER BEARING	ROULEM.A ROUL.			1	1										
180	0630 502 042 90X3 DIN 477	SICHERUNGSRING	RETAINING RING	JONC D'ARRET			1	1										
190	0635 501 150	LAGERINNENRING	BEAR.INNER RING	BAGUE INT.ROULM			1	1										

Gruppe 2052 103 VORGELEGEWELLE  
 Group LAYSCHAFT  
 Groupe ARBRE INTERM.

Stückzahl nach Ausführung / Quantity per model /  
 Nombre par modèle  
 2071 060 21.11.86

Bild Nr. Fig. No. Fig. No.	Teilnummer Partnumber No. de pièce	Benennung	Description	Désignation	Änderung Modification Modification	alle all tous	023	024								
200	0635 501 427	LAGERAUSSENRING	BEAR. OUTER RING	BAGUE EXT. ROULM			1	1								
210		EINSTELLSCHEIBE WAHLWEISE	SHIM OPTIONAL	RONDELLE EN OPTION			1	1								
	4038 303 016	S=3,4					1	1								
	4038 303 062	S=3,2					1	1								
	4038 303 063	S=3,0					1	1								
	4038 303 064	S=2,8					1	1								
	4038 303 065	S=2,6					1	1								
	4038 303 066	S=2,4					1	1								
	4038 303 067	S=2,1					1	1								
	4038 303 072	S=1,8					1	1								
	4038 303 071	S=1,9					1	1								
	4038 303 070	S=2,0					1	1								
	4038 303 068	S=2,3					1	1								
	4038 303 069	S=2,2					1	1								
220	0630 502 122 3 ZOLL X 0,098 ZOLL	SICHERUNGSRING	RETAINING RING	JONC D'ARRET			1	1								
260	0630 531 061 48X2,5 DIN 471	SICHERUNGSRING	RETAINING RING	JONC D'ARRET			1	1								



**Gruppe** 2052 115 **GRUPPENGETRIEBE**  
**Group** RANGE GEARBOX  
**Groupe** GROUPE-RELAIS

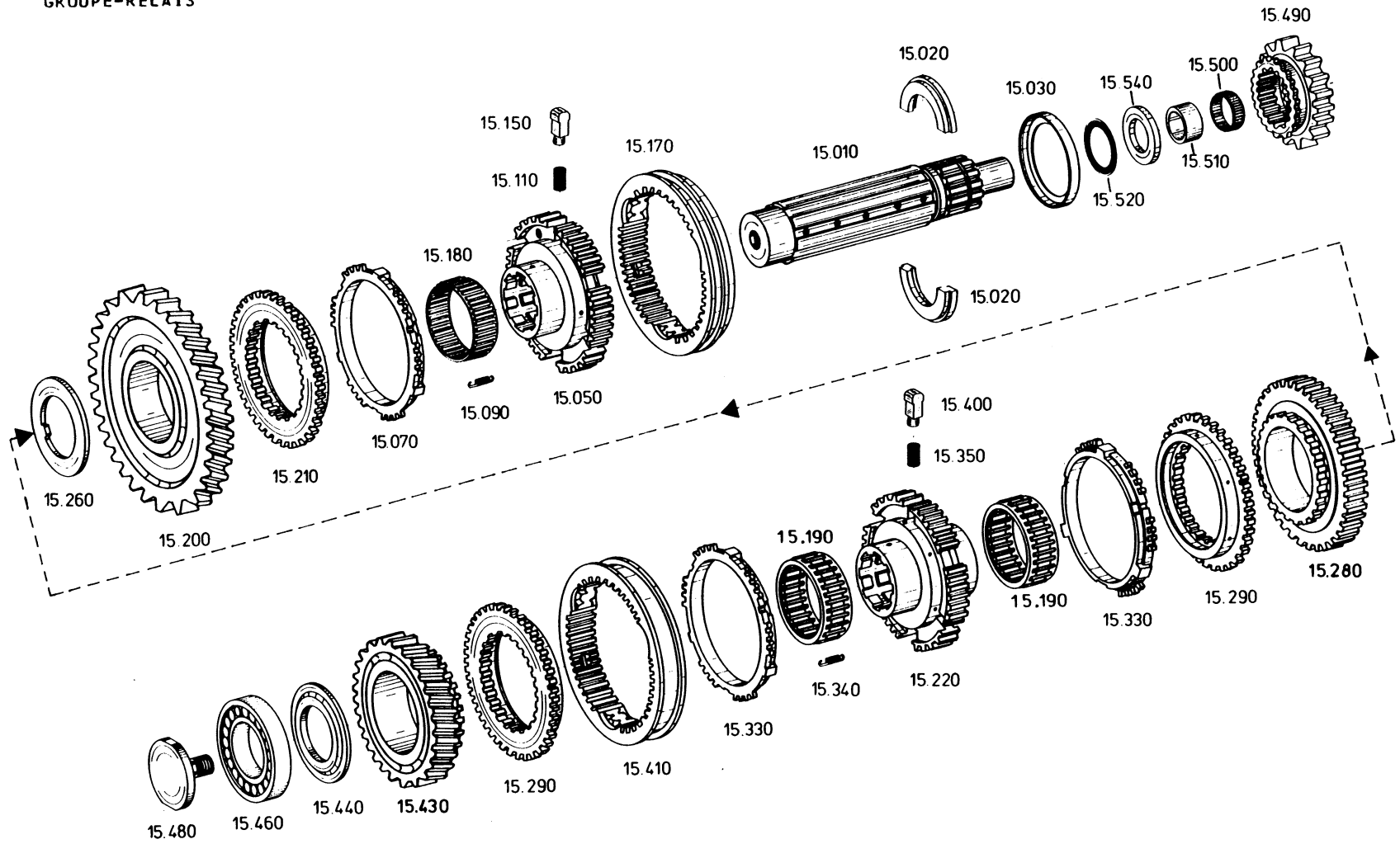

Die Abbildungen sind für die Ausführung nicht verbindlich  
 Illustrations are not binding for the design  
 Les illustrations ne sont pas obligatoires pour l'exécution

Gruppe 2052 115 GRUPPENGETRIEBE  
 Group RANGE GEARBOX  
 Groupe GROUPE-RELAIS

Stückzahl nach Ausführung / Quantity per model /  
 Nombre par modèle  
 2071 060 21.11.86

Bild Nr. Fig. No. Fig. No.	Teilnummer Partnumber No. de pièce	Benennung	Description	Désignation	Änderung Modification Modification	Stückzahl nach Ausführung / Quantity per model / Nombre par modèle															
						alle all tous	023	024													
010	2052 315 291	GRUPPENWELLE	RANGE SHAFT	ARBRE DU GROUPE			1	1													
020	0730 103 201	GETEILTER RING	SPLIT RING	BAGUE DIVISEE			1	1													
030	0730 061 921	SICHERUNGSRING	RETAINING RING	JONC D'ARRET			1	1													
050	2052 215 212	SYNCHRONKÖRPER	SYNCHRO.BODY	MOYEU SYNCHRON.			1	1													
070	2052 315 294	SYNCHRONRING	SYNCHRO.RING	BAGUE SYNCHRO.			1	1													
090	0732 020 066	ZUGFEDER	TENSION SPRING	PES.S.TRACTION			3	3													
110	0732 040 385	DRUCKFEDER	COMPR.SPRING	RESSORT PRESS.			3	3													
150	6002 304 628	DRUCKSTUECK	PRESSURE PIECE	POUSSOIR			3	3													
170	2052 315 308	SCHIEBEMUFFE	SLIDING SLEEVE	MANCHON			1	1													
180	0750 115 081	NADELKAEFIG	NEEDLE CAGE	CAGE A AIG.			1	1													
190	0750 115 080	NADELKAEFIG	NEEDLE CAGE	CAGE A AIG.			2	2													
200	2052 315 337 P-GR.255	STIRNPAD	SPUR GFAP	PIGNON CYLINDR.			1	1													
210	2052 315 283 Z=25	KUPPLGS.KÖRPER	CLUTCH BODY	CORPS D'EMBRAY			1	1													
220	2052 315 289 NZ-GR.	SYNCHRONKÖRPER	SYNCHRO.BODY	MOYEU SYNCHRON.			1	1													
260	0730 200 167	ANLAUFSCHLEIBE	THRUST WASHER	RONDELLE BUTEE			1	1													
280	2052 315 327 Z-GR.242	STIRNRAD	SPUR GEAR	PIGNON CYLINDR.			1	1													
290	2052 315 283 Z=25	KUPPLGS.KÖRPER	CLUTCH BODY	CORPS D'EMBRAY			2	2													
330	2052 315 294	SYNCHRONRING	SYNCHRO.RING	BAGUE SYNCHRO.			2	2													
340	0732 020 030	ZUGFEDER	TENSION SPRING	RESS.TRACTION			3	3													
350	0732 040 385	DRUCKFEDER	COMPR.SPRING	RESSORT PRESS.			3	3													
400	6002 304 628	DRUCKSTUECK	PRESSURE PIECE	POUSSOIR			3	3													
410	2052 315 306	SCHIEBEMUFFE	SLIDING SLEEVE	MANCHON			1	1													

Gruppe 2052 115 GRUPPENGETRIEBE  
 Group RANGE GEARBOX  
 Groupe GROUPE-RELAIS

Stückzahl nach Ausführung / Quantity per model /

Nombre par modèle

2071 060

21.11.86

Bild Nr. Fig. No. Fig. No.	Teilnummer Partnumber No. de pièce	Benennung	Description	Désignation	Änderung Modification Modification	alle all tous	023	024								
430	2052 315 322	STIRNRAD	SPUR GEAR	PIGNON CYLINDR.			1	1								
	N-GR. Z38															
440	2052 315 245	AUSGL. SCHEIBE	SHIM	RONDELLE			1	1								
	S=5,4															
460	0735 410 233	ROLLENLAGER	ROLLER BEARING	ROULEM. A ROUL.			1	1								
480	2052 315 093	SCHRAUBE	SCREW	VIS			1	1								
490	2052 315 311	SCHIFBERAD	SLIDING GEAR	PIGNON BALADEUR			1	1								
	Z=23															
500	0635 300 571	NADELKLANZ	NEEDLE CAGE	CAGE A AIG.			1	1								
510	0730 061 862	BUCHSE	BUSH	DOUILLE			1	1								
520	0635 302 011	AX. NADELKAFIG	AX. NEEDLE CAGE	CAGE AIG. AXIALE			1	1								
540		SCHEIBE	WASHER	RONDELLE			1	1								
		WAHLWEISE	OPTIONAL	EN OPTION												
	0730 104 132	S=3,5					1	1								
	0730 104 133	S=3,6					1	1								
	0730 105 307	S=3,7					1	1								
	0730 104 134	S=3,8					1	1								
	0730 105 308	S=3,9					1	1								
	0730 104 135	S=4,0					1	1								
	0730 105 309	S=4,1					1	1								
	0730 104 136	S=4,2					1	1								
	0730 105 310	S=4,3					1	1								
	0730 104 137	S=4,4					1	1								
	0730 104 138	S=4,6					1	1								
	0730 104 139	S=4,8					1	1								





Gruppe 2052 105 RUECKLAUF  
Group RETURN  
Groupe RETOUR

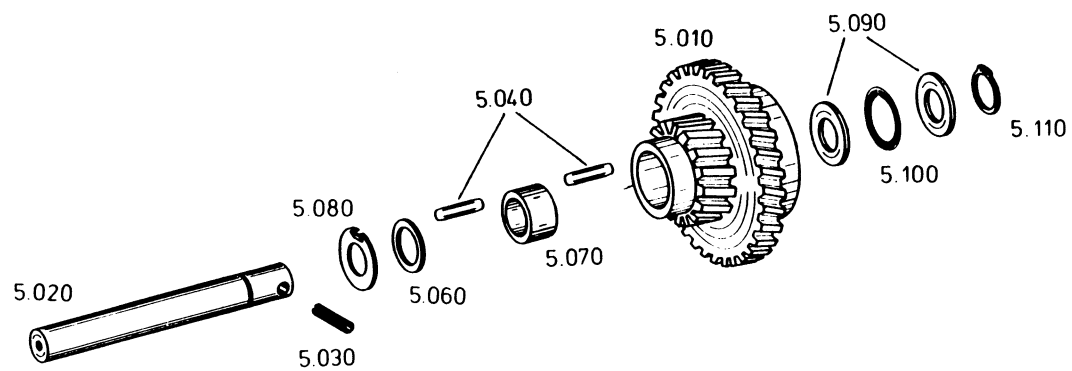

Die Abbildungen sind für die Ausführung nicht verbindlich  
Illustrations are not binding for the design  
Les illustrations ne sont pas obligatoires pour l'exécution

Gruppe 2052 105 RUECKLAUF  
 Group RETURN  
 Groupe RETOUR

Stückzahl nach Ausführung / Quantity per model /  
 Nombre par modèle  
 2071 060 21.11.86

Bild Nr. Fig. No. Fig. No.	Teilnummer Partnumber No. de pièce	Benennung	Description	Désignation	Änderung Modification Modification	alle all tous											
						023	024										
010	2052 205 046	RUECKLAUFRAD	REV.IDLER GEAR	PIGNON M.AR.			1	1									
020	2052 305 050	LAGERBOLZEN	BEARING BOLT	BOUL.DE PALIER			1	1									
030	0631 329 090 8X60 DIN 1481	SPANNSTIFT	SLOT.PIN	GOUPILLE ELAST.			1	1									
040	0735 470 026	LAGERNADEL	BEARING NEEDLE	ATG.DE ROULEMT			28	28									
060	0730 103 083	SCHEIBE	WASHER	RONDELLE			1	1									
070	0730 160 847	BUCHSE	BUSH	DOUILLE			1	1									
080	0730 103 038	ANLAUFSCHLEIBE	THRUST WASHER	RONDELLE BUTEE			1	1									
090	0635 290 034	DRUCKSCHEIBE	PRESSURE DISC	RONDELLE PRESS.			2	2									
100	0635 302 060	AX.NADELKAEFIG	AX.NEEDLE CAGE	CAGE ATG.AXIALE			1	1									
110	0630 501 018 22X1,2 DIN 471	SICHERUNGSRING	RETAINING RING	JONC D'ARRET			1	1									

Gruppe 2052 102 ANTRIEBSWELLE  
Group INPUT SHAFT  
Groupe ARBRE D'ENTREE

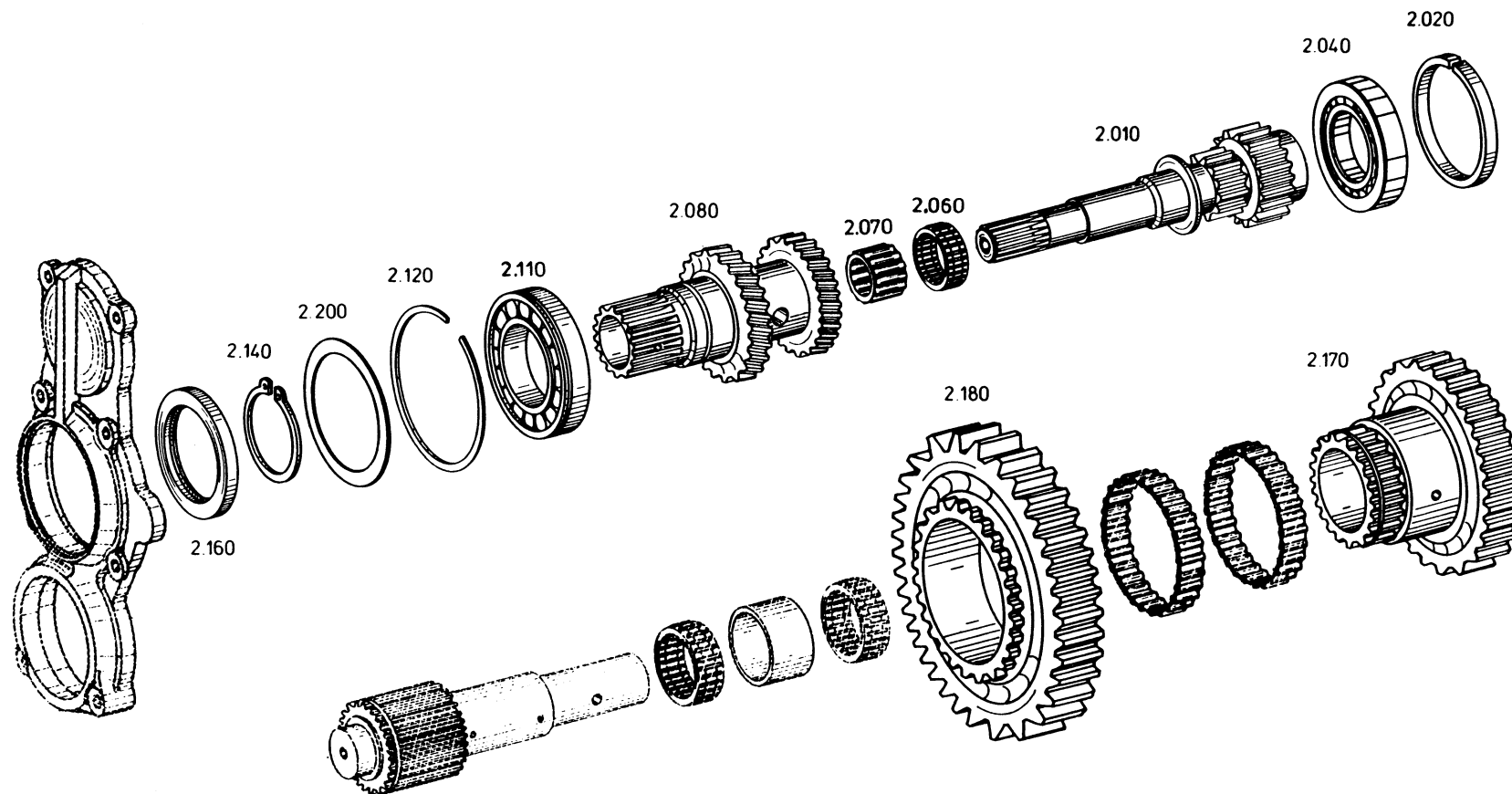

Die Abbildungen sind für die Ausführung nicht verbindlich  
Illustrations are not binding for the design  
Les illustrations ne sont pas obligatoires pour l'exécution

Gruppe 2052 102 ANTRIEBSWELLE  
 Group INPUT SHAFT  
 Groupe ARBRE D'ENTREE

Stückzahl nach Ausführung / Quantity per model /  
 Nombre par modèle  
 2071 060 21.11.86

Bild Nr. Fig. No. Fig. No.	Teilnummer Partnumber No. de pièce	Benennung	Description	Désignation	Änderung Modification Modification	alle all tous											
						023	024										
010	2052 302 185 Z=20	ANTRIEBSWELLE	INPUT SHAFT	ARBRE D'ENTREE			1	1									
070	0730 260 450	RING	RING	BAGUE			1	1									
040	0635 416 014	ROLLENLAGER	ROLLER BEARING	ROULEM.A ROUL.			1	1									
060	0635 300 176	NADELKRANZ	NEEDLE CAGE	CAGE A AIG.			1	1									
070	0635 300 602	NADFLKRANZ	NEEDLE CAGE	CAGE A AIG.			1	1									
080	2052 302 213 Z=33/37	ZAHNWELLE	TOOTHED SHAFT				1	1									
110	0750 116 045	KUGELLAGER	BALL BEARING	ROULEM.A BILLES			1	1									
120	0630 503 018 SP 130 DIN 5417	SPPENGRING	SNAP RING	CIRCLIP			1	1									
140	0630 501 048 75X2,5 DIN 471	SICHERUNGSRING	RETAINING RING	JONC D'ARRET			1	1									
160	0734 319 064	WELLENDICHTRING	SHAFT SEAL	BAGUE ETANCH.			1	1									
170	2052 310 167 Z=45	STIRNRAD	SPUR GEAR	PIGNON CYLINDR.			1	1									
180	2052 310 164 Z=51	STIRNRAD	SPUR GEAR	PIGNON CYLINDR.			1	1									
200		PASS-SCHEIBE WAHLWEISE	SHIM RING OPTIONAL	RONDELLE AJUST. EN OPTION			1	1									
	0630 004 124 PS 105X130X0,3	PASS-SCHEIBE	SHIM RING	RONDELLE AJUST.			1	1									
	0630 004 229 PS 105X130X0,2	PASS-SCHEIBE	SHIM RING	RONDELLE AJUST.			1	1									
	0630 004 123 PS 105X130X0,1	PASS-SCHEIBE	SHIM RING	RONDELLE AJUST.			1	1									

Gruppe 2052 104 HAUPTWELLE  
 Group MAIN SHAFT  
 Groupe ARBRE PRINCIPAL

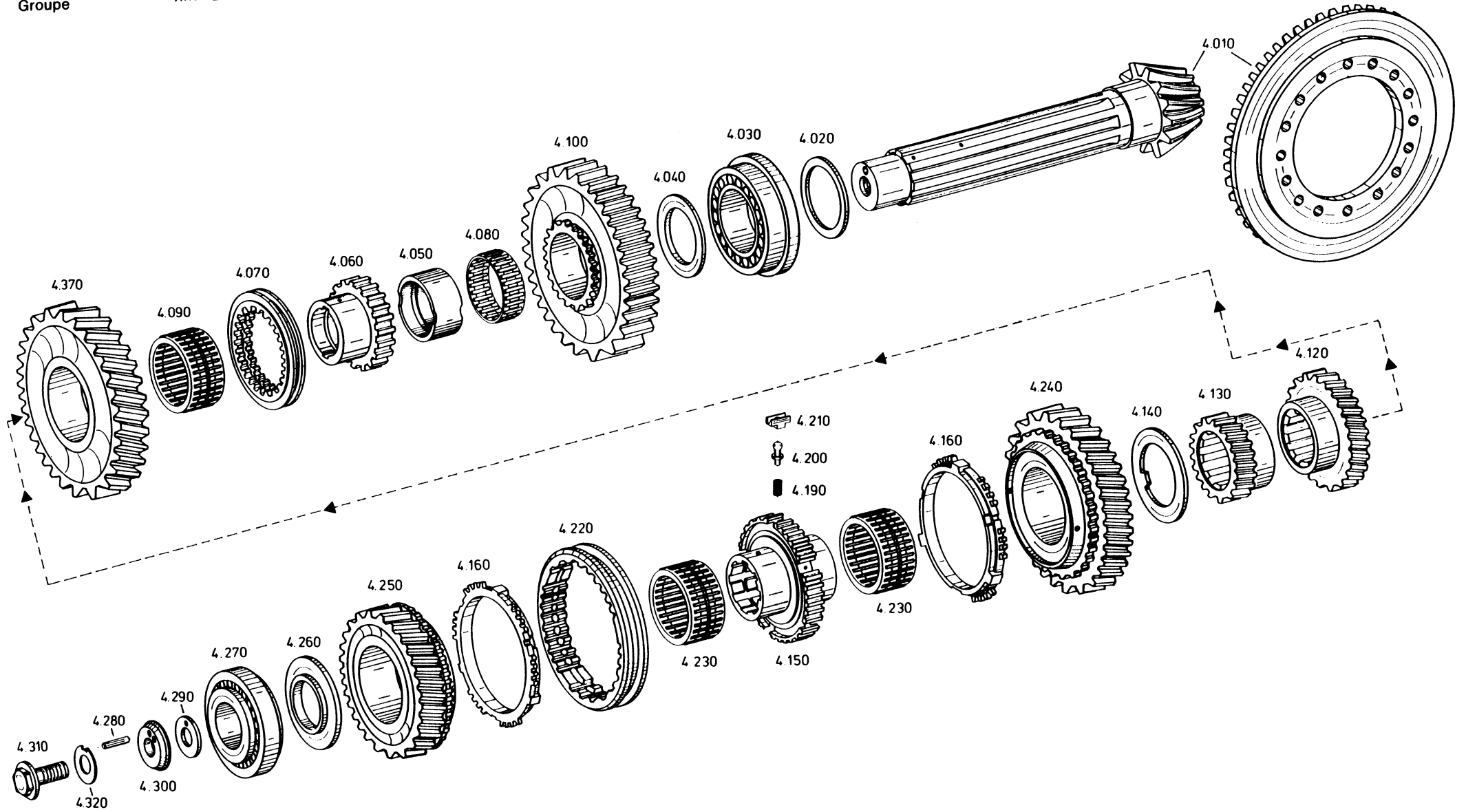

Die Abbildungen sind für die Ausführung nicht verbindlich  
 Illustrations are not binding for the design  
 Les illustrations ne sont pas obligatoires pour l'exécution

Gruppe 2052 104 HAUPTWELLE  
 Group MAIN SHAFT  
 Groupe ARBRE PRINCIPAL

Stückzahl nach Ausführung / Quantity per model /  
 Nombre par modèle  
 2071 060 21.11.86

Bild Nr. Fig. No. Fig. No.	Teilnummer Partnumber No. de pièce	Benennung	Description	Désignation	Aenderung Modification Modification	alle all tous	023	024								
010	2052 204 149	KEGELRADSATZ	BEVEL GEAR SET	COUPLE CONIQUE			1	1								
	UEBERS.0															
020		FINSTELLSCHEIBE	SHIM	RONDELLE			1	1								
		WAHLWEISE	OPTIONAL	EN OPTION												
	0730 102 633	S=3,0					1	1								
	S=3,0															
	0730 102 634	S=2,8					1	1								
	S=2,8															
	0730 102 635	S=2,6					1	1								
	S=2,6															
	0730 102 636	S=2,4					1	1								
	S=2,4															
	0730 102 637	S=2,3					1	1								
	S=2,3															
	0730 102 638	S=2,2					1	1								
	S=2,2															
	0730 102 639	S=2,1					1	1								
	S=2,1															
030	0750 117 219	ROLLENLAGER	ROLLER BEARING	ROULEM.A ROUL.			1	1								
040	0730 102 942	ANLAUFSCHIEBE	THRUST WASHER	RONDELLE BUTEE			1	1								
	S=5,0															
050	0730 161 204	LAUFBUCHSE	BUSH	DOUILLE			1	1								
060	2052 304 366	MUFFENTRAEGER	SLEEVE CARRIER	PORTE-MANCHON			1	1								
	1+2 G															
070	2052 304 246	SCHIEBEMUFFE	SLIDING SLEEVE	MANCHON			1	1								
080	0750 115 080	NADELKAEFIG	NEEDLE CAGE	CAGE A AIG.			1	1								
090	0750 115 079	NADELKAEFIG	NEEDLE CAGE	CAGE A AIG.			1	1								
100	2052 304 357	STIRNPAD	SPUR GEAR	PIGNON CYLINDR.			1	1								
	Z=52/1.G															
120	2052 304 365	STIRNRAD 5.G.					1	1								
	Z=32 5.G															
130	2052 304 364	STIRNRAD 6.G.					1	1								
	Z=21 6.G															
140	0730 200 166	ANLAUFSCHIEBE	THRUST WASHER	RONDELLE BUTEE			1	1								
150	2052 304 319	SYNCHRONKORPER	SYNCHRO.BODY	MOYEU SYNCHRON.			1	1								
	3.+4.GG															
160	2052 304 311	SYNCHRONRING	SYNCHRO.RING	BAGUE SYNCHRO.			2	2								

Gruppe 2052 104 HAUPTWELLE  
 Group MAIN SHAFT  
 Groupe ARBRE PRINCIPAL

Stückzahl nach Ausführung / Quantity per model /

Nombre par modèle

2071 060

21.11.86

Bild Nr. Fig. No. Fig. No.	Teilnummer Partnumber No. de pièce	Benennung	Description	Désignation	Änderung Modification Modification	Stückzahl nach Ausführung / Quantity per model / Nombre par modèle														
						alle all tous	023	024												
190	0732 040 409	DRUCKFEDER	COMPR. SPRING	RESSORT PRESS.				3	3											
200	1249 304 323	KUGELBOLZEN	BALL PIN	BOULON A ROTULE				3	3											
210	2052 304 360	DRUCKSTUECK	PRESSURE PIECE	POUSSOIR				3	3											
220	1238 304 357	SCHIEBEMUFFE	SLIDING SLEEVE	MANCHON				1	1											
230	0750 115 079	NADELKAEFIG	NEEDLE CAGE	CAGE A AIG.				2	2											
								1	1											
240	2052 304 349	STIRNRAD ANLAUFTEIL	SPUR GEAR INTRODUCTION DATE	PIGNON CYLINDR. MOMENT DE DEMARRAGE	22481			1	1											
	0899 308 398	STIRNRAD AUSLAUFTEIL	SPUR GEAR TERMINATING DATE	PIGNON CYLINDR. MOMENT DE TERMNAISON	22481			1	1											
250	2052 204 145	STIRNRAD 4.G. ANLAUFTEIL	SPUR GEAR INTRODUCTION DATE	PIGNON CYL.4E MOMENT DE DEMARRAGE	22481			1	1											
	0899 201 308	STIRNRAD 4.G. AUSLAUFTEIL	SPUR GEAR TERMINATING DATE	PIGNON CYL.4E MOMENT DE TERMNAISON	22481			1	1											
260		AUSGL.SCHEIBE WAHLWEISE	SHIM OPTIONAL	RONDELLE EN OPTION				1	1											
	2052 304 290	S=9,05						1	1											
	2052 304 291	S=8,90						1	1											
	2052 304 292	S=8,75						1	1											
	2052 304 293	S=8,60						1	1											
	2052 304 294	S=8,45						1	1											
	2052 304 295	S=8,30						1	1											
	2052 304 296	S=8,15						1	1											
	2052 304 297	S=8,00						1	1											
	2052 304 298	S=7,85						1	1											
	2052 304 299	S=7,70						1	1											



Gruppe 2052 104 HAUPTWELLE  
 Group MAIN SHAFT  
 Groupe ARBRE PRINCIPAL

Stückzahl nach Ausführung / Quantity per model /  
 Nombre par modèle  
 2071 060 21.11.86

Bild Nr. Fig. No. Fig. No.	Teilnummer Partnumber No. de pièce	Benennung	Description	Désignation	Änderung Modification Modification	alle all tous												
						023	024											
	2052 304 300 S=7,55	S=7,55					1	1										
	2052 304 301 S=7,40	S=7,40					1	1										
	2052 304 302 S=7,25	S=7,25					1	1										
	2052 304 303 S=7,10	S=7,10					1	1										
	2052 304 304 S=6,95	S=6,95					1	1										
	2052 304 305 S=6,80	S=6,80					1	1										
	2052 304 395 S=7,75	S=7,75					1	1										
	2052 304 396 S=7,80	S=7,80					1	1										
	2052 304 397 S=7,90	S=7,90					1	1										
	2052 304 398 S=7,95	S=7,95					1	1										
	2052 304 399 S=8,05	S=8,05					1	1										
	2052 304 400 S=8,10	S=8,10					1	1										
	2052 304 401 S=8,20	S=8,20					1	1										
270	0735 370 036	ROLLENLAGER	ROLLER BEARING	ROULEM.A ROUL.			1	1										
280	0631 309 008 6X20 DIN 1474	KERBSTIFT	GROOVED PIN	GOUP.CANNELEE			1	1										
290		SCHIEBE WAHLWEISE	WASHER OPTIONAL	RONDELLE EN OPTION			1	1										
	0730 002 727 S=3,5	S=3,5					1	1										
	0730 002 728 S=3,4	S=3,4					1	1										
	0730 002 729 S=3,3	S=3,3					1	1										
	0730 002 730 S=3,2	S=3,2					1	1										

Gruppe 2052 104 HAUPTWELLE  
 Group MAIN SHAFT  
 Groupe ARBRE PRINCIPAL

Stückzahl nach Ausführung / Quantity per model /  
 Nombre par modèle  
 2071 060 21.11.86

Bild Nr. Fig. No. Fig. No.	Teilnummer Partnumber No. de pièce	Benennung	Description	Désignation	Anderung Modification Modification	Stückzahl nach Ausführung / Quantity per model / Nombre par modèle																
						alle all tous	023	024														
	0730 002 731 S=3,1	S=3,1					1	1														
	0730 002 732 S=3,0	S=3,0					1	1														
	0730 002 733 S=2,9	S=2,9					1	1														
	0730 002 734 S=2,8	S=2,8					1	1														
	0730 002 735 S=2,7	S=2,7					1	1														
	0730 002 736 S=2,6	S=2,6					1	1														
	0730 002 737 S=2,5	S=2,5					1	1														
	0730 002 738 S=2,4	S=2,4					1	1														
	0730 002 739 S=2,3	S=2,3					1	1														
	0730 002 743 S=2,2	S=2,2					1	1														
	0730 002 744 S=2,1	S=2,1					1	1														
	0730 002 745 S=2,0	S=2,0					1	1														
	0730 002 746 S=1,9	S=1,9					1	1														
	0730 002 747 S=1,8	S=1,8					1	1														
	0730 002 748 S=1,7	S=1,7					1	1														
	0730 002 749 S=1,6	S=1,6					1	1														
	0730 002 750 S=1,5	S=1,5					1	1														
	0730 002 751 S=1,4	S=1,4					1	1														
	0730 002 752 S=1,3	S=1,3					1	1														
	0730 002 753 S=1,2	S=1,2					1	1														
300	2052 304 261	SCHEIBE	WASHER	RONDELLE			1	1														
310	0736 617 024	BUNDSCHRAUBE	COLLAR SCREW	VIS A EMBASE			1	1														

Gruppe 2052 104 HAUPTWELLE  
 Group MAIN SHAFT  
 Groupe APBRE PRINCIPAL

Stückzahl nach Ausführung / Quantity per model /  
 Nombre par modèle  
 2071 060 21.11.86

Bild Nr. Fig. No. Fig. No.	Teilnummer Partnumber No. de pièce	Benennung	Description	Désignation	Änderung Modification Modification	alle all tous	023	024								
320	0730 603 022	SICHERUNGSBLECH	TAB WASHER	TOLE-FREIN			1	1								
370	2052 304 376 2.GG.	SCHRAEGRAD	HELICAL GEAR	PIGN.DENT.HELIC			1	1								

Gruppe 2052 110 ZAPFWELLE  
 Group P.T.O. SHAFT  
 Groupe PRISE DE FORCE

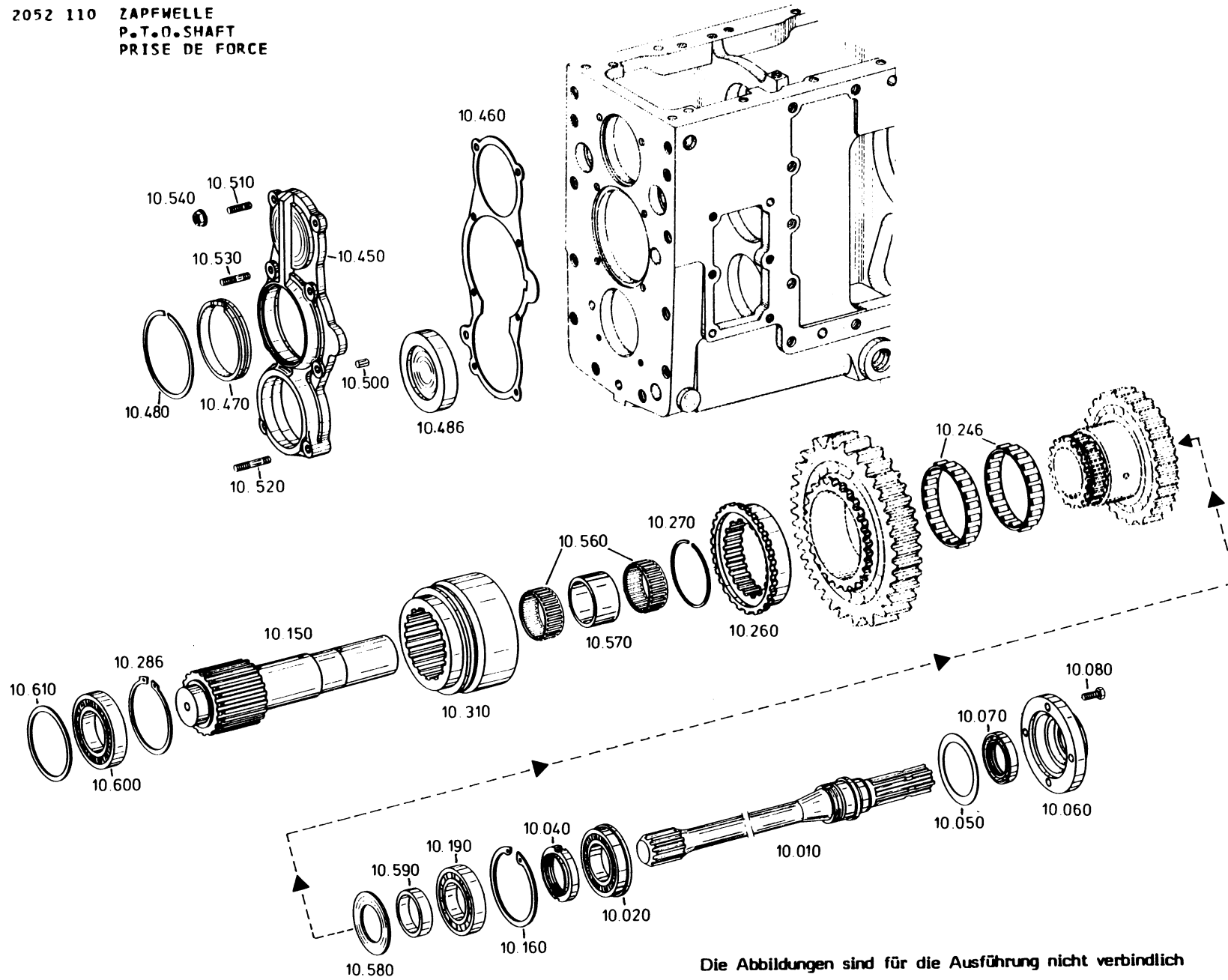

Die Abbildungen sind für die Ausführung nicht verbindlich  
 Illustrations are not binding for the design  
 Les illustrations ne sont pas obligatoires pour l'exécution

Gruppe 2052 110 ZAPFWELLE  
 Group P.T.O.SHAFT  
 Groupe PRISE DE FORCE

Stückzahl nach Ausführung / Quantity per model /  
 Nombre par modèle  
 2071 060 21.11.86

Bild Nr. Fig. No. Fig. No.	Teilnummer Partnumber No. de pièce	Benennung	Description	Désignation	Änderung Modification Modification	Stückzahl nach Ausführung / Quantity per model / Nombre par modèle														
						alle all tous	023	024												
010	2052 310 208	ZAPFWELLE	P.T.O.SHAFT	PRISE DE FORCE			1	1												
020	0735 340 043	KUGELLAGER	BALL BEARING	ROULEM.A BILLES			1	1												
040	0737 502 128	NUTMUTTER	SLOTTED NUT	ECROU CANNELE			1	1												
050		PASS-SCHEIBE WAHLWEISE	SHIM RING OPTIONAL	RONDELLE AJUST. EN OPTION			1	1												
	0630 004 076 75X95X0,2 DIN 988	PASS-SCHEIBE	SHIM RING	RONDELLE AJUST.			1	1												
	0630 000 231 75X95X0,1 DIN 988	PASS-SCHEIBE	SHIM RING	RONDELLE AJUST.			1	1												
060	2052 310 037	ABSCHLUSSDECKEL	END COVER	COUVERCLE AR.			1	1												
070	0734 309 060	WELLENDICHTRING	SHAFT SEAL	BAGUE ETANCH.			1	1												
080	0636 015 089 M 8X25 DIN 933 8.8	6KT.SCHRAUBE	HEXAGON SCREW	VIS HEXAGONALE			4	4												
150	2052 310 135	ZWISCHENWELLE	INTERM.SHAFT	ARBRE INTERM.			1	1												
160	0630 502 042 90X3 DIN 472	SICHERUNGSRING	PETAINING RING	JONC D'ARRET			1	1												
190	0635 416 010	ROLLENLAGER	ROLLER BEARING	ROULEM.A ROUL.			1	1												
246	0635 300 250	NADELKRANZ	NEEDLE CAGE	CAGE A AIG.			2	2												
260	2052 310 138	MUFFENTRAEGER	SLEEVE CARRIER	PORTE-MANCHON			1	1												
270	0630 503 011 SP 85 DIN 5417	SPRENGRING	SNAP RING	CIRCLIP			1	1												

Gruppe 2052 110 ZAPFWELLE  
 Group P.T.O.SHAFT  
 Groupe PRISE DE FORCE

Bild Nr. Fig. No. Fig. No.	Teilnummer Partnumber No. de pièce	Benennung	Description	Désignation	Änderung Modification Modification	alle all tous	023	024							
286	0630 501 053 88X3 DIN 471	SICHERUNGSRING	RETAINING RING	JONC D'ARRET			1	1							
310	2052 310 187	SCHALTMUFFE	G.SHIFT SLEEVE	MANCHON CDE			1	1							
450	2052 310 158	VERSCHL.DECKEL	SEALING CAP	COUVERCLE			1	1							
460	2052 310 156	DICHTUNG	GASKET	JOINT			1	1							
470	2052 310 144	RING	RING	BAGUE			1	1							
480	0630 513 029 SW 110	SPRENGRING	SNAP RING	CIRCLIP			1	1							
486	2052 310 035	VERSCHL.STUECK	PLUG	OBTURATEUR			1	1							
500	0631 306 071 10M6X16 ZFN 6	ZYLINDERSTIFT	CYLINDRICAL PIN	GOUPILLE CYL.			1	1							
510	0636 610 216 M 8X22 DIN 939 10.9	STIFTSCHRAUBE	STUD	GOUJON			2	2							
520	0636 610 217 M 8X40 DIN 939 10.9	STIFTSCHRAUBE	STUD	GOUJON			2	2							
530	0636 610 027 M 8X30 DIN 939 10.9	STIFTSCHRAUBE	STUD	GOUJON			4	4							
540	0637 011 528 M 8	DICHTMUTTER	SEALING NUT	ECROU ETANCH.			8	8							
560	0501 305 254	NADELKAEFIG	NEEDLE CAGE	CAGE A AIG.			2	2							
570	0730 062 158	BUCHSE	BUSH	DOUILLE			1	1							

Gruppe 2052 110 ZAPFWELLE  
 Group P.T.O.SHAFT  
 Groupe PRISE DE FORCE

Stückzahl nach Ausführung / Quantity per model /  
 Nombre par modèle  
 2071 060 21.11.86

Bild Nr. Fig. No. Fig. No.	Teilnummer Partnumber No. de pièce	Benennung	Description	Désignation	Anderung Modification Modification	Stückzahl nach Ausführung / Quantity per model / Nombre par modèle														
						alle all tous	023	024												
580	0730 103 413	ANLAUFSSCHEIBE	THRUST WASHER	RONDELLE BUTEE			1	1												
590	0730 062 152	BUCHSE	BUSH	DOUILLE			1	1												
600	0750 116 034	KUGELLAGER	BALL BEARING	ROULEM.A BILLES			1	1												
610		EINSTELLSCHLEIBE WAHLWEISE	SHIM OPTIONAL	RONDELLE EN OPTION			1	1												
	0730 001 009	S=2,0					1	1												
	0730 001 010	S=1,4					1	1												
	0730 001 011	S=0,6					1	1												
	0730 001 012	S=0,4					1	1												
	0730 000 126	S=0,2					1	1												

Gruppe 2052 142  
Group  
Groupe

ZAPFW.SCHALTUNG  
PTO SH.CONTROL  
COMMANDE DE PDF

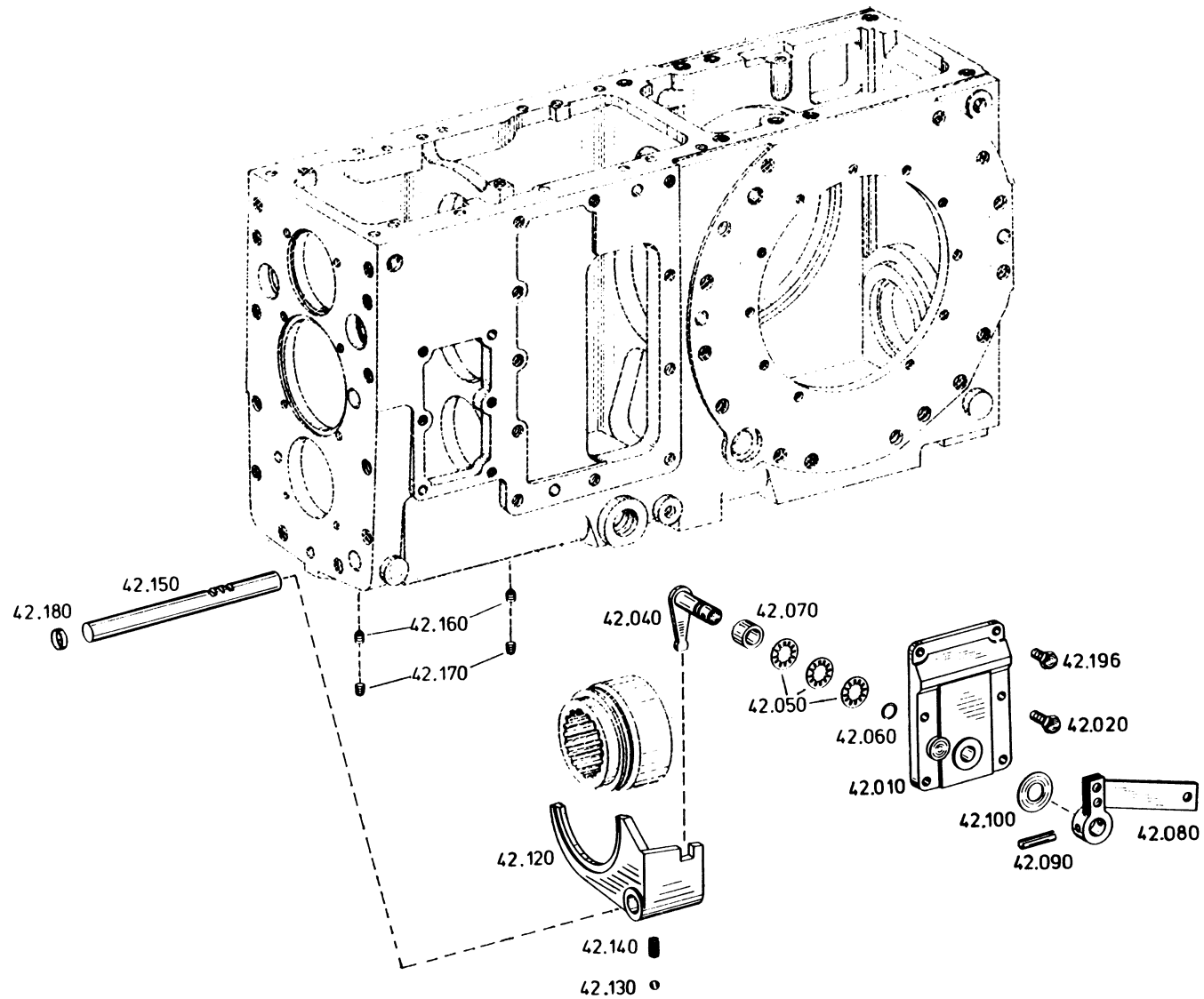

Die Abbildungen sind für die Ausführung nicht verbindlich  
Illustrations are not binding for the design  
Les illustrations ne sont pas obligatoires pour l'exécution



Gruppe 2052 142 ZAPFW.SCHALTUNG  
 Group PTO SH.CONTROL  
 Groupe COMMANDE DE PDF

Stückzahl nach Ausführung / Quantity per model /  
 Nombre par modèle  
 2071 060 21.11.86

Bild Nr. Fig. No. Fig. No.	Teilnummer Partnumber No. de pièce	Benennung	Description	Désignation	Änderung Modification Modification	Stückzahl nach Ausführung / Quantity per model / Nombre par modèle														
						alle all tous	023	024												
010	2052 342 069	DECKEL	COVER	COUVERCLE			1	1												
020	0636 015 127 M 10X30 DIN 933 N.8	6KT.SCHRAUBE	HEXAGON SCREW	VIS HEXAGONALE			4	4												
040	2052 242 051	SCHALTHEBEL	G.SHIFT LEVER	LEVIER CDE VIT.			1	1												
050	0632 051 016 36,6X20,4X0,4	TELLERFEDER	CUP SPRING	RONDELLE BELLEV			3	3												
060	0634 306 015 15,3X2,4 7FN 744	O-RING	O-RING	JOINT TORIQUE			1	1												
070	0730 061 024	ROHR	PIPE	TUBE			1	1												
080	2052 242 047	SCHALTHEBEL	G.SHIFT LEVER	LEVIER CDE VIT.				1												
	2052 242 057	SCHALTHEBEL	G.SHIFT LEVER	LEVIER CDE VIT.			1													
090	0631 329 085 RX36 DIN 1481	SPANNSTIFT	SLOT.PIN	GOUPILLE ELAST.			1	1												
100	0730 150 185	SCHEIBE	WASHER	RONDELLE			1	1												
120	2052 342 056	SCHALTGABEL	GEAR SHIFT FORK	FOURCH.PASS.VIT			1	1												
130	0635 460 021	KUGEL	BALL	BILLE			1	1												
140	1203 313 004	DRUCKFEDER	COMPR.SPRING	RESSORT PRESS.			1	1												
150	2052 342 057	SCHALTSCHIENE	GEAR SHIFT RAIL	GLISSIERE CDE			1	1												
160	1238 306 065	GEWINDESTIFT	SET SCREW	GOUJON FILETE			2	2												
170	0636 303 002 M 10X1 DIN 909	VERSCHL.SCHR.	SCREW PLUG	VIS FERMETURE			2	2												

Gruppe 2052 142 ZAPFW.SCHALTUNG  
 Group PTD SH.CONTROL  
 Groupe COMMANDE DE PDF

Stückzahl nach Ausführung / Quantity per model /  
 Nombre par modèle  
 2071 060 21.11.86

Bild Nr. Fig. No. Fig. No.	Teilnummer Partnumber No. de pièce	Benennung	Description	Désignation	Änderung Modification Modification	alle all tous	023	024								
180	0630 361 033 20 DIN 443	VERSCHL. DECKEL	SEALING CAP	COUVERCLE			1	1								
196	0636 015 114 M 10X22 DIN 933 8.8	6KT. SCHRAUBE	HEXAGON SCREW	VIS HEXAGONALE			2	2								



Gruppe 2052 109 Ausgleichgetriebe  
 Group Differential  
 Groupe Differential

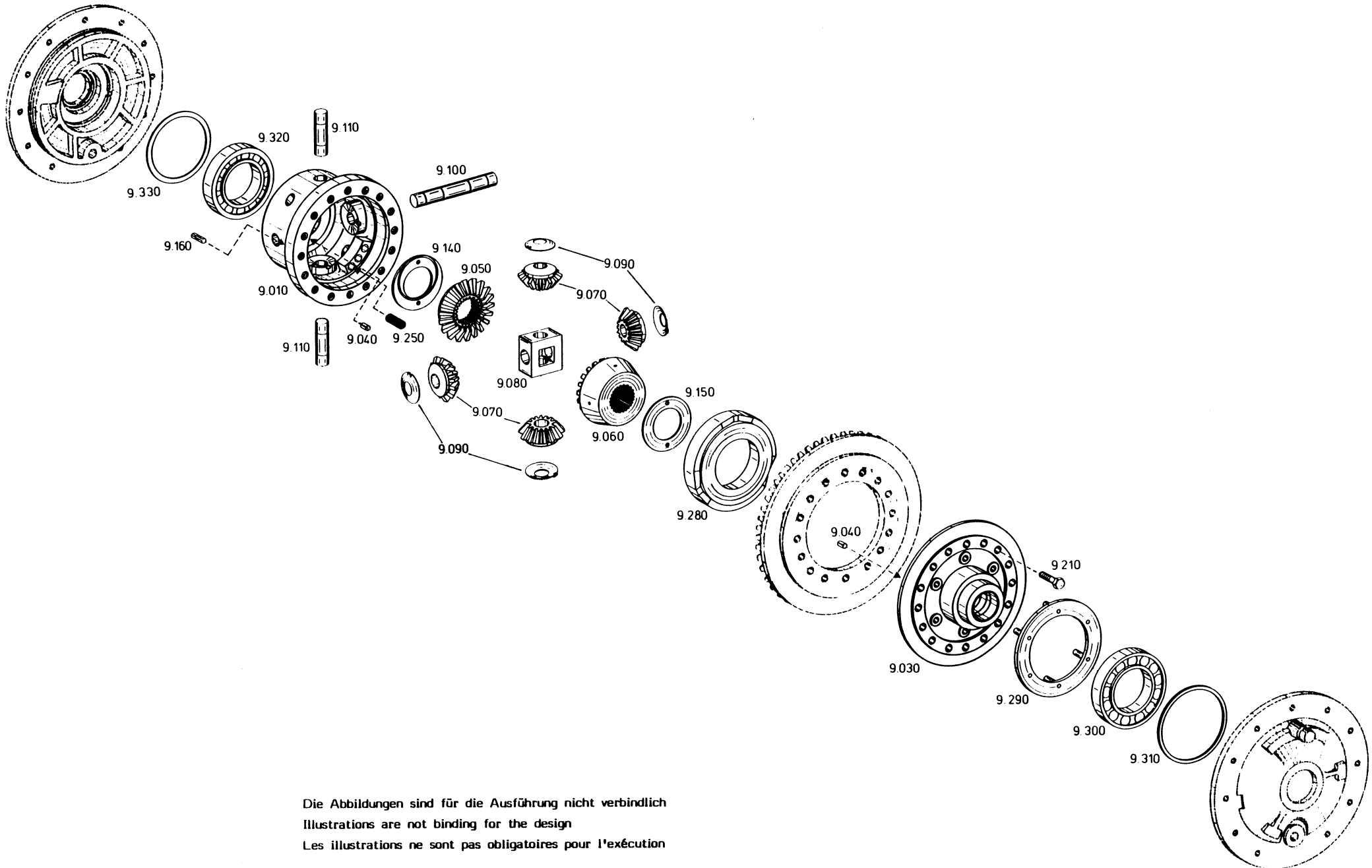

Die Abbildungen sind für die Ausführung nicht verbindlich  
 Illustrations are not binding for the design  
 Les illustrations ne sont pas obligatoires pour l'exécution

Gruppe 2052 109 AUSGL.GETRIEBE  
 Group DIFFERENTIAL  
 Groupe DIFFERENTIEL

Stückzahl nach Ausführung / Quantity per model /  
 Nombre par modèle  
 2071 060 21.11.86

Bild Nr. Fig. No. Fig. No.	Teilnummer Partnumber No. de pièce	Benennung	Description	Désignation	Änderung Modification Modification	alle all tous											
						023	024										
010	2052 209 098	AUSGL.GEHAEUSE	DIFF.CASE	BOITIER DE DIFF			1	1									
030	2052 209 094	FLANSCH	FLANGE	BRIDE			1	1									
040	0731 305 002	KERBSTIFT	GROOVED PIN	GOUP.CANNELEE			4	4									
050	2052 309 132	ACHSKEGELRAD	AXLE BEVEL GEAR	PLANETAIRE			1	1									
060	2052 309 140	ACHSKEGELRAD	AXLE BEVEL GEAR	PLANETAIRE			1	1									
070	2052 309 131	AUSGL.KEGELRAD	DIFF.BEVEL GEAR	SATELLITE DIFF.			4	4									
080	2052 309 014	KREUZSTUECK	CROSS JOINT	CROISILLON			1	1									
090	0730 101 033	ANLAUFSCHLEIBE	THRUST WASHER	RONDELLE BUTEE			4	4									
100	2052 309 069	BOLZEN	PIN	BOULON			1	1									
110	2052 309 070	BOLZEN	PIN	BOULON			2	2									
140	0730 150 385	AUSGL.SCHEIBE	SHIM	RONDELLE			1	1									
150		AUSGL.SCHEIBE	SHIM	RONDELLE			1	1									
		WAHLWEISE	OPTIONAL	EN OPTION													
	0730 150 375	S=2,0					1	1									
	0730 150 376	S=2,1					1	1									
	0730 150 377	S=2,2					1	1									
	0730 150 378	S=2,3					1	1									
	0730 150 379	S=2,4					1	1									
	0730 150 380	S=2,5					1	1									
	0730 150 381	S=2,6					1	1									
	0730 150 382	S=2,7					1	1									
	0730 150 383	S=2,8					1	1									
	0730 150 384	S=2,9					1	1									
160	0631 329 064	SPANNSTIFT	SLOT.PIN	GOUPILLE ELAST.			4	4									
	6X20																
	DIN 1481																
210	0636 011 023	6KT.SCHRAUBE	HEXAGON SCREW	VIS HEXAGONALE			16	16									
	M 12X50																
	DIN 931																
	8.8																

Bild Nr. Fig. No. Fig. No.	Teilnummer Partnumber No. de pièce	Benennung	Description	Désignation	Änderung Modification Modification	alle all tous	023	024							
250	0732 040 439	DRUCKFEDER	COMPR.SPRING	RESSORT PRESS.			12	12							
280	2052 309 086	SYNCHRONRING	SYNCHRO.RING	BAGUE SYNCHRO.			1	1							
290	2052 209 107	RING	RING	BAGUE			1	1							
300	0635 371 031	ROLLENLAGER	ROLLER BEARING	ROULEM.A ROUL.			1	1							
310		AUSGL.SCHEIBE WAHLWEISE	SHIM OPTIONAL	RONDELLE EN OPTION			1	1							
	2049 309 507	S=2,9					1	1							
	2049 309 090	S=2,8					1	1							
	2049 309 506	S=2,7					1	1							
	2049 309 091	S=2,6					1	1							
	2049 309 525	S=2,5					1	1							
	2049 309 524	S=2,4					1	1							
	2049 309 523	S=2,3					1	1							
	2049 309 532	S=2,2					1	1							
	2049 309 533	S=2,1					1	1							
	2049 309 534	S=2,0					1	1							
	2049 309 535	S=1,9					1	1							
	2049 309 536	S=1,8					1	1							
320	0750 117 106	ROLLENLAGER	ROLLER BEARING	ROULEM.A ROUL.			1	1							
330		SCHEIBE WAHLWEISE	WASHER OPTIONAL	RONDELLE EN OPTION			1	1							
	0730 002 542	S=2,0					1	1							
	0730 002 543	S=1,9					1	1							

Gruppe 2052 109 AUSGL.GETRIEBE  
 Group DIFFERENTIAL  
 Groupe DIFFERENTIEL

Stückzahl nach Ausführung / Quantity per model /  
 Nombre par modèle  
 2071 060 21.11.86

Bild Nr. Fig. No. Fig. No.	Teilnummer Partnumber No. de pièce	Benennung	Description	Désignation	Änderung Modification Modification	Stückzahl nach Ausführung / Quantity per model / Nombre par modèle														
						alle all tous	023	024												
	0730 002 544 S=1,8	S=1,8					1	1												
	0730 002 545 S=1,7	S=1,7					1	1												
	0730 002 546 S=1,6	S=1,6					1	1												
	0730 002 547 S=1,5	S=1,5					1	1												
	0730 002 548 S=1,4	S=1,4					1	1												
	0730 002 549 S=1,3	S=1,3					1	1												
	0730 002 550 S=1,2	S=1,2					1	1												

Gruppe 2052 138  
Group  
Groupe

AUSGLEICHSPERRE  
DIFF.INTERLOCK  
VERR.DIFFERENT.

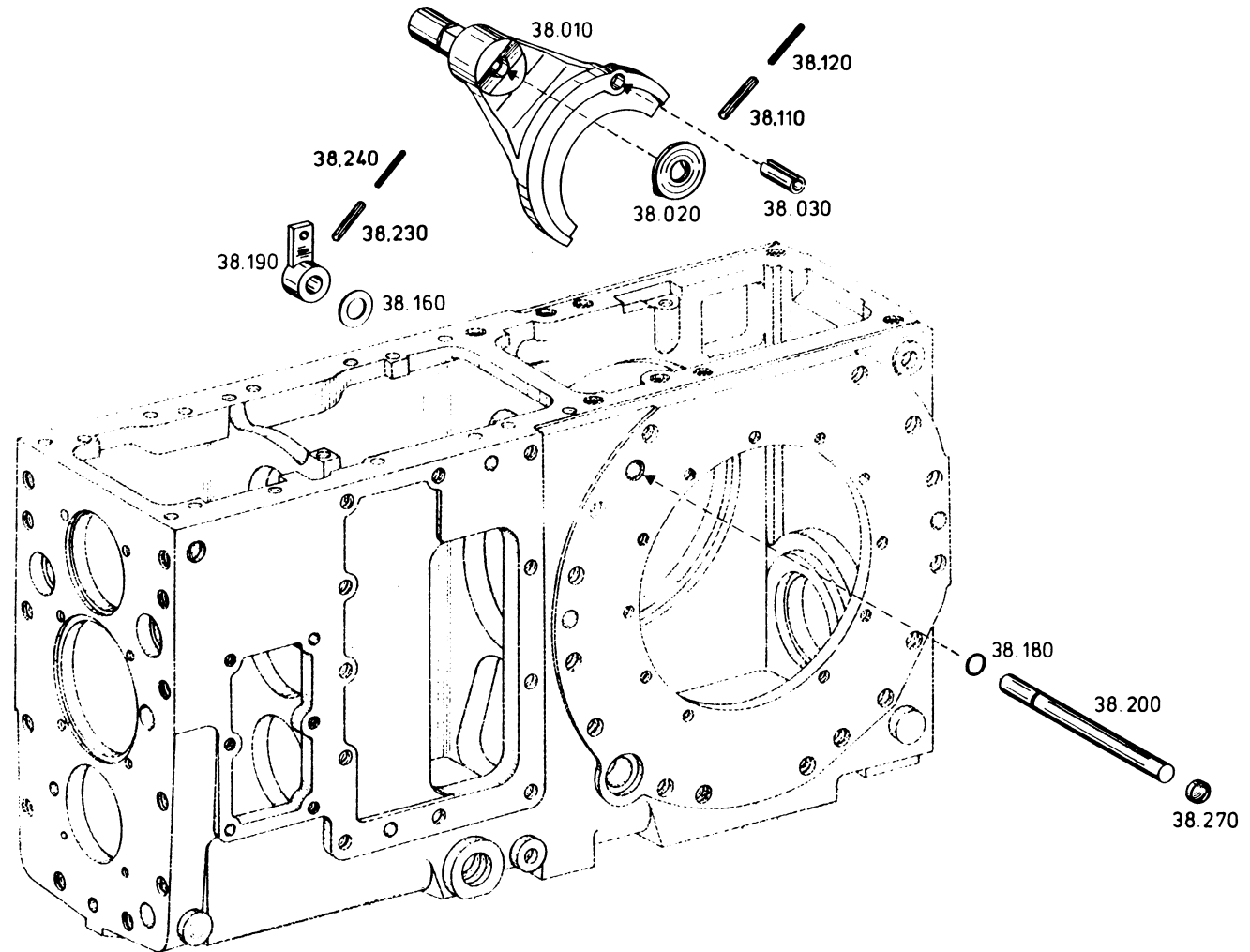

Die Abbildungen sind für die Ausführung nicht verbindlich  
Illustrations are not binding for the design  
Les illustrations ne sont pas obligatoires pour l'exécution



Gruppe 2052 138 AUSGLEICHSPERRE  
 Group DIFF.INTERLOCK  
 Groupe VERR.DIFFERENT.

Stückzahl nach Ausführung / Quantity per model /  
 Nombre par modèle  
 2071 060 21.11.86

Bild Nr. Fig. No. Fig. No.	Teilnummer Partnumber No. de pièce	Benennung	Description	Désignation	Änderung Modification Modification	Stückzahl nach Ausführung / Quantity per model / Nombre par modèle														
						alle all tous	023	024												
010	2052 338 082	SCHALTGABEL	GEAR SHIFT FORK	FOURCH.PASS.VIT			1	1												
070	2052 338 030	NOCKEN	CAM	CAME			1	1												
030	0631 320 200 16X50 DIN 1481	SPANNSTIFT	SLOT.PIN	GOUPILLE ELAST.			1	1												
110	0631 320 086 8X40 DIN 1481	SPANNSTIFT	SLOT.PIN	GOUPILLE ELAST.			1	1												
120	0631 320 057 5X40 DIN 1481	SPANNSTIFT	SLOT.PIN	GOUPILLE ELAST.			1	1												
160		AUSGL.SCHEIBE WAHLWEISE	SHIM OPTIONAL	RONDELLE EN OPTION			1	1												
	0730 102 026	S=2,0					1	1												
	0730 102 027	S=1,5					1	1												
	0730 102 028	S=1,0					1	1												
180	0634 303 161 17X1,5 ZFN 744	O-RING	O-RING	JOINT TORIQUE			1	1												
190	2052 238 016	DIFF.SPERRHEBEL	DIFF.LOCK LEVER	LEV.BLOC.DIFF.			1	1												
200	2052 338 078	WELLE	SHAFT	ARBRE			1	1												
230	0631 320 086 8X40 DIN 1481	SPANNSTIFT	SLOT.PIN	GOUPILLE ELAST.			1	1												
240	0631 320 057 5X40 DIN 1481	SPANNSTIFT	SLOT.PIN	GOUPILLE ELAST.			1	1												
270	0630 361 033 20 DIN 443	VERSCHL.DECKEL	SEALING CAP	COUVERCLE			1	1												

Gruppe 2071 111 ABTRIEB RECHTS U. LINKS, BREMSE  
 Group FINAL DRIVE RH/LH, BRAKE  
 Groupe SORTIE DROITE/GAUCHE, FREIN

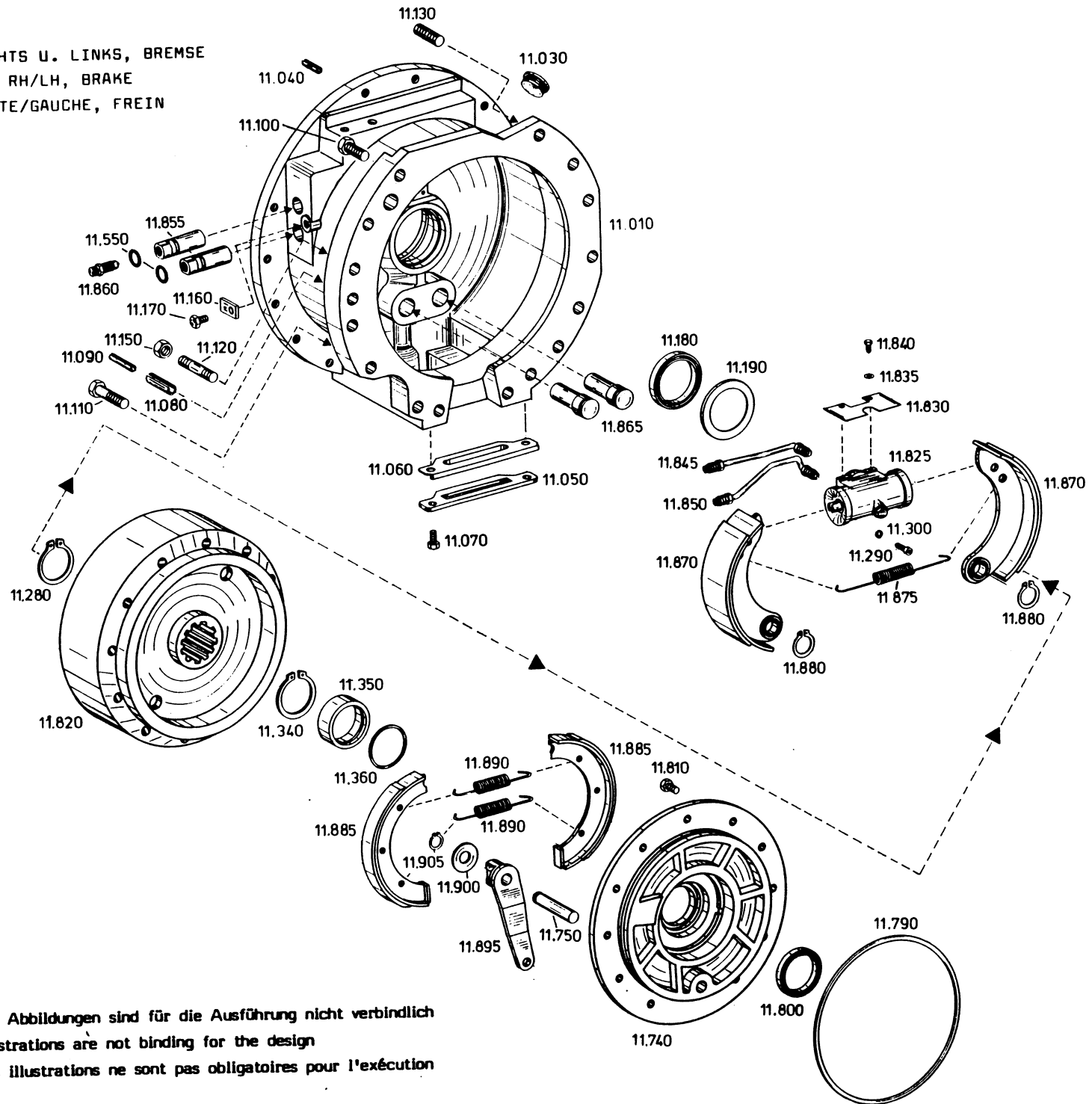

Die Abbildungen sind für die Ausführung nicht verbindlich  
 Illustrations are not binding for the design  
 Les illustrations ne sont pas obligatoires pour l'exécution

Gruppe 2071 111  
Group  
Groupe

ABTRIEB RECHTS U. LINKS, BREMSE  
FINAL DRIVE RH/LH, BRAKE  
SORTIE DROITE/GAUCHE, FREIN

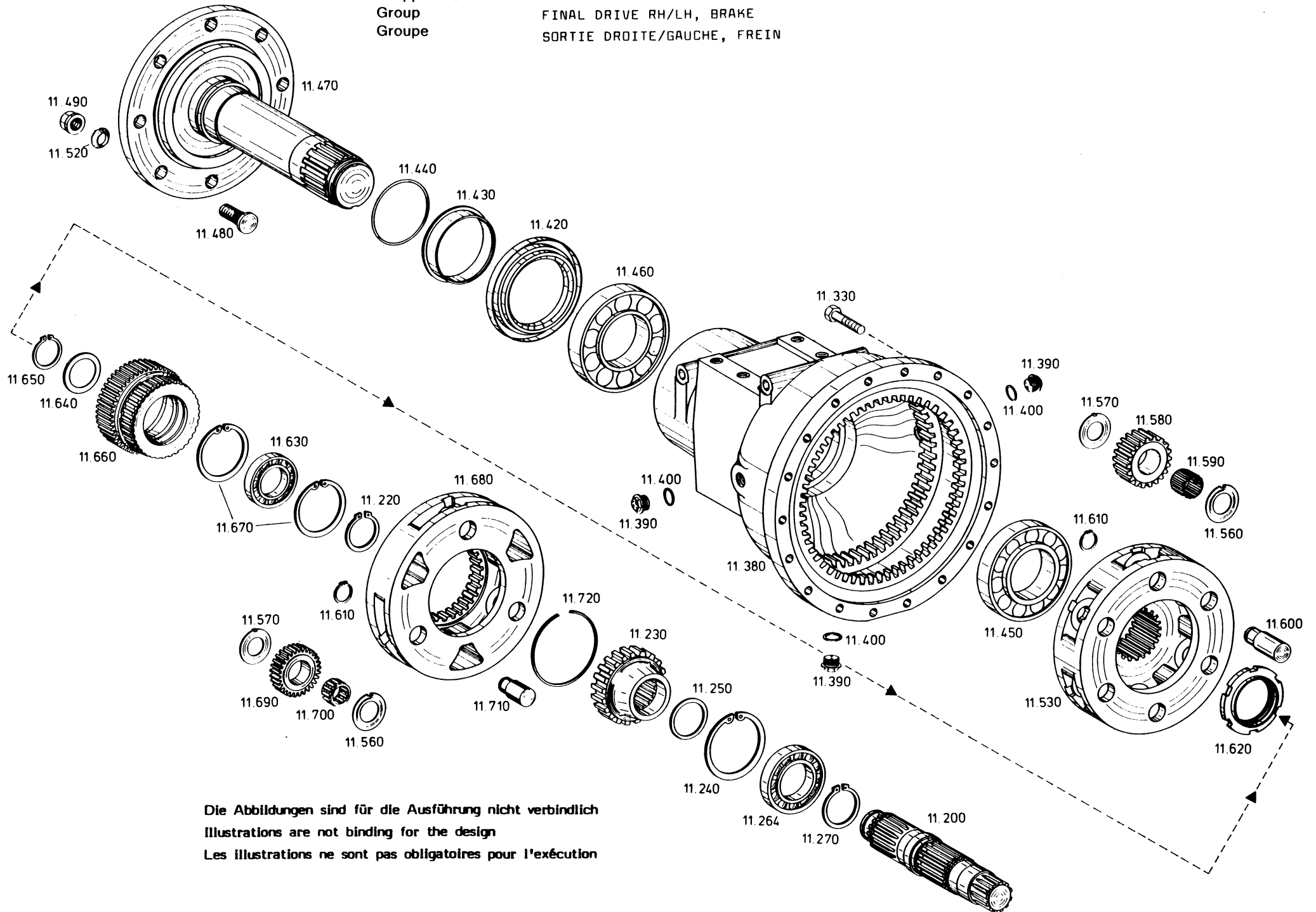

Die Abbildungen sind für die Ausführung nicht verbindlich  
Illustrations are not binding for the design  
Les illustrations ne sont pas obligatoires pour l'exécution

Gruppe 2071 111 ABTRIEB RE/LI  
 Group OUTPUT RH/LH  
 Groupe SORTIE

Stückzahl nach Ausführung / Quantity per model /  
 Nombre par modèle

2071 060

21.11.86

Bild Nr. Fig. No. Fig. No.	Teilnummer Partnumber No. de pièce	Benennung	Description	Désignation	Änderung Modification Modification	alle all tous												
						023	024											
010	2071 311 195 RECHTS	BREMSGEHÄUSE	BRAKE HOUSING	CARTER DE FREIN			1	1										
	2071 311 194 LINKS	BREMSGEHÄUSE	BRAKE HOUSING	CARTER DE FREIN			1	1										
030	0636 302 010 M 42X1,5 DIN 908	VERSCHL.SCHR.	SCREW PLUG	VIS FERMETURE			2	2										
040	0631 329 100 10X40 DIN 1481	SPANNSTIFT	SLOT.PIN	GOUPILLE ELAST.			6	6										
050	2068 311 300	ABDECKBLECH	COVER PLATE	TOLE PROTECTION			2	2										
060	2068 311 301	BALG					2	2										
070	0636 015 147 M 10X18 DIN 933 8.8	6KT.SCHRAUBE	HEXAGON SCREW	VIS HEXAGONALE			4	4										
080	0631 329 219 16X60 DIN 1481	SPANNSTIFT	SLOT.PIN	GOUPILLE ELAST.			2	2										
090	0631 329 218 10X60 DIN 1481	SPANNSTIFT	SLOT.PIN	GOUPILLE ELAST.			2	2										
100	0636 016 086 M 16X45 DIN 933 10.9	6KT.SCHRAUBE	HEXAGON SCREW	VIS HEXAGONALE			6	6										
110	0636 011 241 M 16X70 DIN 931 10.9	6KT.SCHRAUBE	HEXAGON SCREW	VIS HEXAGONALE			14	14										
120	0636 611 178 M 16X65 DIN 939 10.9	STIFTSCHRAUBE	STUD	GOUJON			8	8										

Gruppe 2071 111 ABTRIEB RE/LI Group OUTPUT RH/LH Groupe SORTIE						Stückzahl nach Ausführung / Quantity per model / Nombre par modèle 2071 060 21.11.86										
Bild Nr. Fig. No. Fig. No.	Teilnummer Partnumber No. de pièce	Benennung	Description	Désignation	Änderung Modification Modification	alle all tous	023	024								
130	0636 611 172 M 16X35 DIN 939 10.9	STIFTSCHRAUBE	STUD	GOUJON			2	2								
150	0637 006 066 M 16 DIN 934 10	6KT.MUTTER	HEXAGON NUT	ECROU HEXAGONAL			10	10								
160	2068 311 199	HALTERLECH	FIXING PLATE	TOLE SUPPORT			2	2								
170	0636 015 147 M 10X18 DIN 933 8.8	6KT.SCHRAUBE	HEXAGON SCREW	VIS HEXAGONALE			2	2								
180	0734 309 041	WELLENDICHRING	SHAFT SEAL	BAGUE ETANCH.			2	2								
190	2068 311 229	SCHUTZRING	PROTECTING RING	BAGUE PROTECTR.			2	2								
200	2071 311 156 RECHTS 2071 311 155 LINKS	SEITENWELLE	SIDE SHAFT	ARBRE LATERAL			1	1								
220	0630 531 073 58X3 DIN 471	SICHERUNGSRING	PETAINING PING	JONC D'ARRET			2	2								
230	2071 311 160 Z=36	SONNENPAD	SUN GEAR	PLANETAIRE			2	2								
240	0630 502 047 110X4 DIN 472	SICHERUNGSRING	RETAINING RING	JONC D'ARRET			2	2								
250	0630 526 007 61X71X0,5X3,5	AUSGL.SCHEIBE	SHIM	RONDELLE			2	2								
264	0750 116 051	KUGFLAGER	BALL BEARING	ROULEM.A BILLES			2	2								
270	0630 531 076 60X3 DIN 471	SICHERUNGSRING	PETAINING RING	JONC D'ARRET			2	2								

Gruppe 2071 111 ABTRIEB RE/LI  
 Group OUTPUT RH/LH  
 Groupe SORTIE

Stückzahl nach Ausführung / Quantity per model /  
 Nombre par modèle  
 2071 060 21.11.86



Bild Nr. Fig. No. Fig. No.	Teilnummer Partnumber No. de pièce	Benennung	Description	Désignation	Änderung Modification Modification	Stückzahl nach Ausführung / Quantity per model / Nombre par modèle														
						alle all tous	023	024												
280	0630 501 041 60X2 DIN 471	SICHERUNGSRING	RETAINING RING	JONC D'ARRET			2	2												
290	0636 101 031 M 8X30 DIN 912 8.8	ZYL.SCHRAUBE	CAP SCREW	VIS TETE CYL.			4	4												
300	0630 305 002 8 DIN 7980	FEDERRING	SPRING WASHER	BAGUE ELASTIQUE			4	4												
330	0636 011 265 M 12X60 DIN 931 10.9	6KT.SCHRAUBE	HEXAGON SCREW	VIS HEXAGONALE			36	36												
340	0630 501 040 58X2 DIN 471	SICHERUNGSRING	RETAINING RING	JONC D'ARRET			2	2												
350	2068 311 194	BUCHSE	BUSH	DOUILLE			2	2												
360	0634 306 509 55X3 ZFN 744	O-RING	O-RING	JOINT TORIQUE			2	2												
380	2071 211 012	ACHSROHR	AXLE TUBE	TROMPETTE			2	2												
390	0736 304 017	VERSCHL.SCHR.	SCREW PLUG	VIS FERMETURE			6	6												
400	0634 801 200 A 24X29 DIN 7603	DICHTRING	SEALING RING	BAGUE ETANCH.			6	6												
420	0734 300 068	WELLENDICHTRING	SHAFT SEAL	BAGUE ETANCH.			2	2												

Gruppe 2071 111 ABTRIEB RE/LI Group OUTPUT P.H/LH Groupe SORTIE						Stückzahl nach Ausführung / Quantity per model / Nombre par modèle 2071 060 21.11.86										
Bild Nr. Fig. No. Fig. No.	Teilnummer Partnumber No. de pièce	Benennung	Description	Désignation	Änderung Modification Modification	alle all tous	023	024								
430	2071 311 164	BUCHSE	BUSH	DOUILLE			2	2								
440	0634 306 302 105X3 ZFN 744	O-RING	O-RING	JOINT TORIQUE			2	2								
450	0750 117 077	ROLLENLAGER	ROLLER BEARING	ROULEM.A ROUL.			2	2								
460	0750 117 042	ROLLENLAGER	ROLLER BEARING	ROULEM.A ROUL.			2	2								
470	2071 311 198	HINTERACHSWELLE	REAR AXLE SHAFT	ARBRE DE PONT			2	2								
480	4401 303 053	RADBOLZEN	WHEEL BOLT	BOULON DE ROUE			16	16								
490	0637 018 025 B 22 DIN 74361	RADMUTTER	WHEEL NUT	ECROU DE ROUE			16	16								
520	0630 307 011 C 22,5 DIN 74361	FEDERRING	SPRING WASHER	RAGUE ELASTIQUE			16	16								
530	2071 311 087	PLANETENTRAEGER	PLANET CARRIER	PORTE-SATELL.			2	2								
550	0634 306 194 16X3 ZFN 744	O-RING	O-RING	JOINT TORIQUE			4	4								
560	0730 103 288	ANLAUFSCHETBE	THRUST WASHER	RONDELLE BUTEE			18	18								
570	0730 103 287	ANLAUFSCHETBE	THRUST WASHER	RONDELLE BUTEE			18	18								
580	2071 311 093 Z=23	PLANETENRAD	PLANET GEAR	SATELLITE			12	12								
590	0735 320 252	NADELKAFFIG	NEEDLE CAGE	CAGE A AIG.			12	12								
600	2071 311 091	BOLZEN	PIN	BOULON			12	12								

Gruppe 2071 111 ABTRIEB RE/LI  
 Group OUTPUT RH/LH  
 Groupe SORTIE

Stückzahl nach Ausführung / Quantity per model /  
 Nombre par modèle

2071 060

21.11.86

Bild Nr. Fig. No. Fig. No.	Teilnummer Partnumber No. de pièce	Benennung	Description	Désignation	Änderung Modification Modification	Stückzahl nach Ausführung / Quantity per model / Nombre par modèle														
						alle all tous	023	024												
610	0630 501 024 30X1,5 DIN 471	SICHERUNGSRING	RETAINING RING	JONC D'ARRET			18	18												
620	0737 502 103	NUTMUTTER	SLOTTED NUT	ECROU CANNELE			2	2												
630	0750 116 034	KUGELLAGER	BALL BEARING	ROULEM.A BILLES			2	2												
640	0730 000 883	SCHEIBE	WASHER	RONDELLE			2	2												
650	0630 531 061 48X2,5 DIN 471	SICHERUNGSRING	RETAINING RING	JONC D'ARRET			2	2												
660	2071 311 161 Z=45	SONNENRAD	SUN GEAR	PLANETAIRE			2	2												
670	0630 502 042 90X3 DIN 472	SICHERUNGSRING	RETAINING RING	JONC D'ARRET			4	4												
680	2071 311 157	PLANETENTRAEGER	PLANET CARRIER	PORTE-SATELL.			2	2												
690	2071 311 094 Z=28	PLANETENRAD	PLANET GEAR	SATELLITE			6	6												
700	0735 358 069	NADELKAFFIG	NEEDLE CAGE	CAGE A AIG.			6	6												
710	2071 311 092	BOLZEN	PIN	BOULON			6	6												
720	0630 513 011 SW 135	SPRENGRING	SNAP RING	CIRCLIP			2	2												
740	2052 309 142 RECHTS	LAGERDECKEL	BEARING COVER	COUVERCLE			1	1												
750	0731 201 266	BOLZEN	PIN	BOULON			2	2												
	2052 309 141 LINKS	LAGERDECKEL	BEARING COVER	COUVERCLE			1	1												
790	0634 304 049 240X3 ZFN 744	O-RING	O-RING	JOINT TORIQUE			2	2												









2052 125

FESTST.BREMSBET.  
P. BRAKE ACTUAT.  
COMMANDE FREIN STAT.

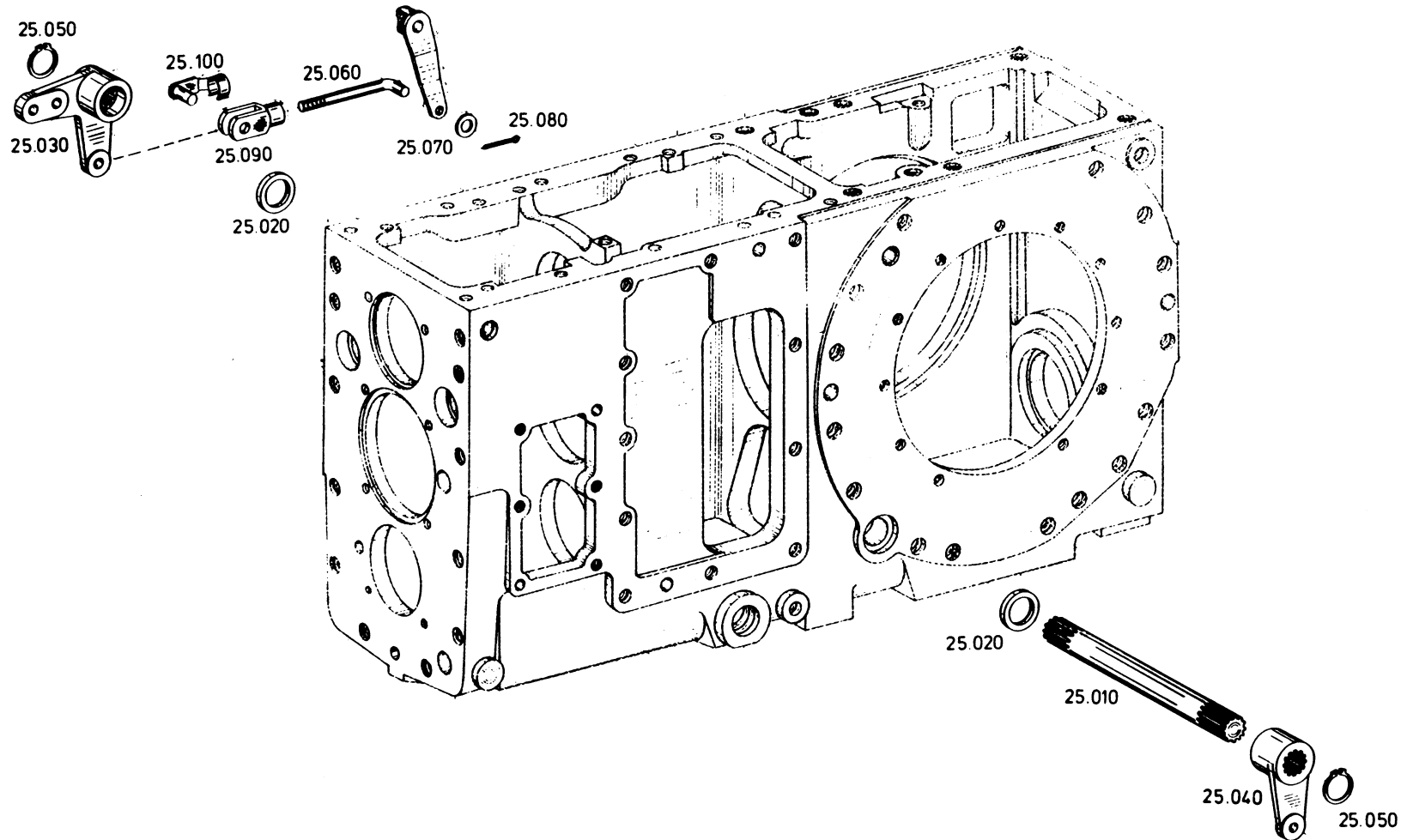

Die Abbildungen sind für die Ausführung nicht verbindlich  
Illustrations are not binding for the design  
Les illustrations ne sont pas obligatoires pour l'exécution

Gruppe 2052 125 FESTST.BREMSBET  
 Group P.BRAKE ACTUAT.  
 Groupe COE FREIN STAT.

Stückzahl nach Ausführung / Quantity per model /  
 Nombre par modèle  
 2071 060 21.11.86

Bild Nr. Fig. No. Fig. No.	Teilnummer Partnumber No. de pièce	Benennung	Description	Désignation	Änderung Modification Modification	Stückzahl nach Ausführung / Quantity per model / Nombre par modèle														
						alle all tous	023	024												
010	2052 325 001	BREMSWELLE	BRAKE SHAFT	ARBRE DE FREIN			1	1												
020	0634 300 355 30X40X7 B ZFN 132	WELLENDICHTRING	SHAFT SEAL	BAGUE ETANCH.			2	2												
030	2052 325 089 RECHTS	BREMSHEBEL	BRAKE PISTON	LEVIER DE FREIN			1	1												
040	2052 325 003	BREMSHEBEL	BRAKE PISTON	LEVIER DE FREIN			1	1												
050	0630 501 023 29X1,5 DIN 471	SICHERUNGSRING	RETAINING RING	JONC D'ARRET			2	2												
060	2052 325 090	ZUGSTANGE	DRAW BAR	BARRE DE FORCE			2	2												
070	0630 001 016 A 13 DIN 125	SCHEIBE	WASHER	RONDELLE			2	2												
080	0631 701 035 4X20 DIN 94	SPLINT	SPLIT PIN	GOUPILLE			2	2												
090	0632 101 007 G 12X24 DIN 71752	GABELKOPF	FORK HEAD	CHAPE			2	2												
100	0631 225 011 12X24SXN01	BOLZEN	PIN	BOULON			2	2												

Tafel 2052 146 VORDERR. ANTRIEB  
 Table 2052 146 FRONT WHEEL DRIVE  
 Planche 2052 146 COMMANDE ROUES AV.

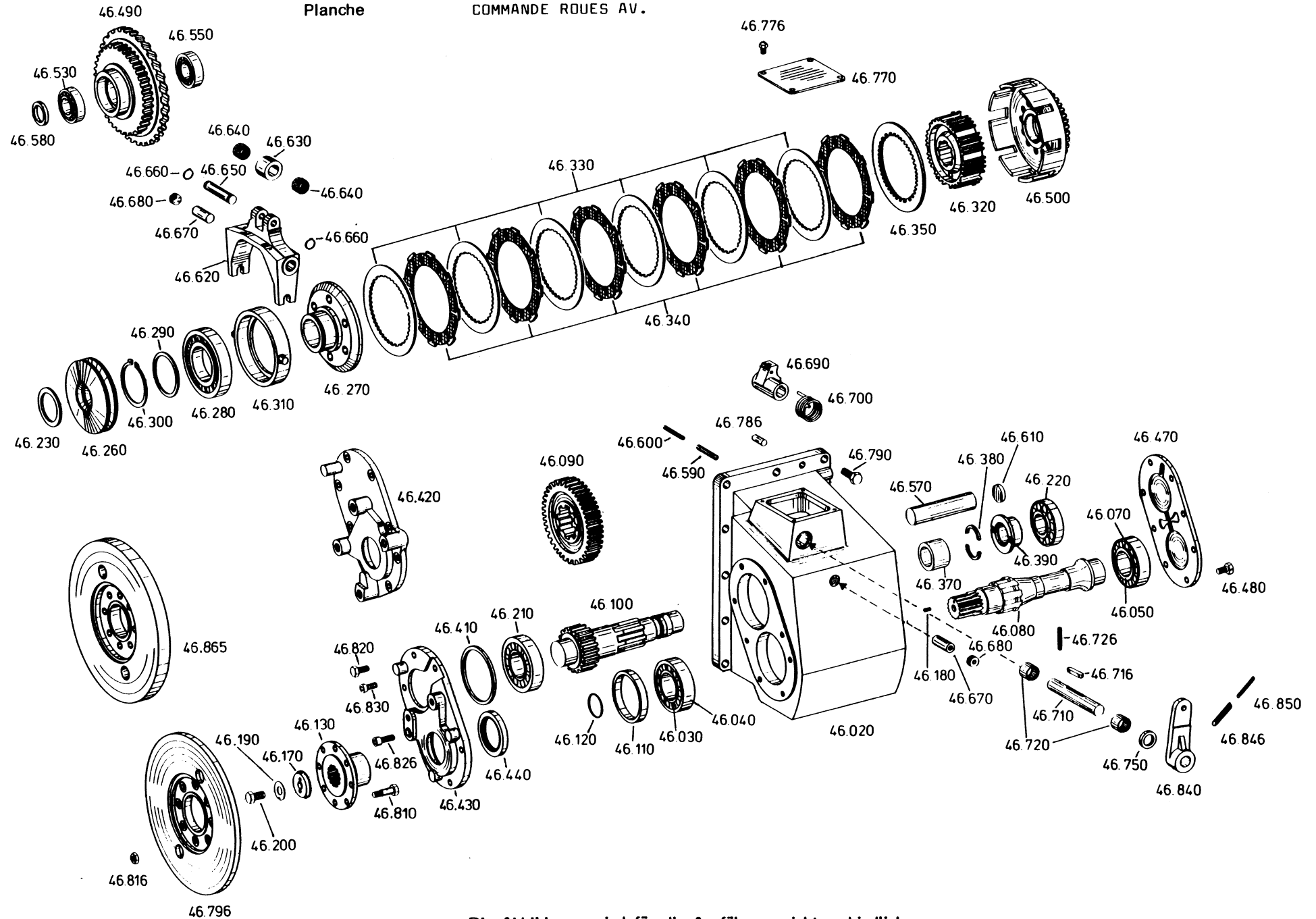

Die Abbildungen sind für die Ausführung nicht verbindlich  
 Illustrations are not binding for the design  
 Les illustrations ne sont pas obligatoires pour l'exécution

Gruppe 2052 146 VORDERRADANTR.  
 Group FRONT WH.DRIVE  
 Groupe ENTRAIN.ROUE AV

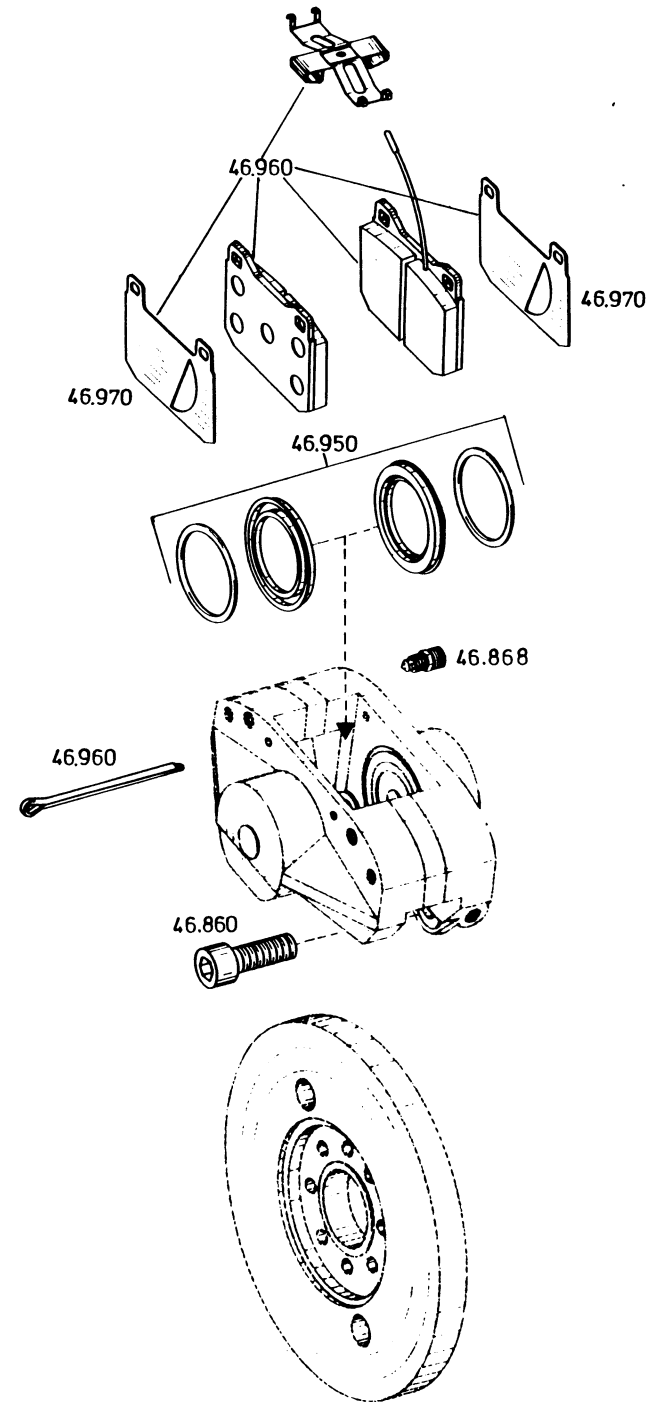
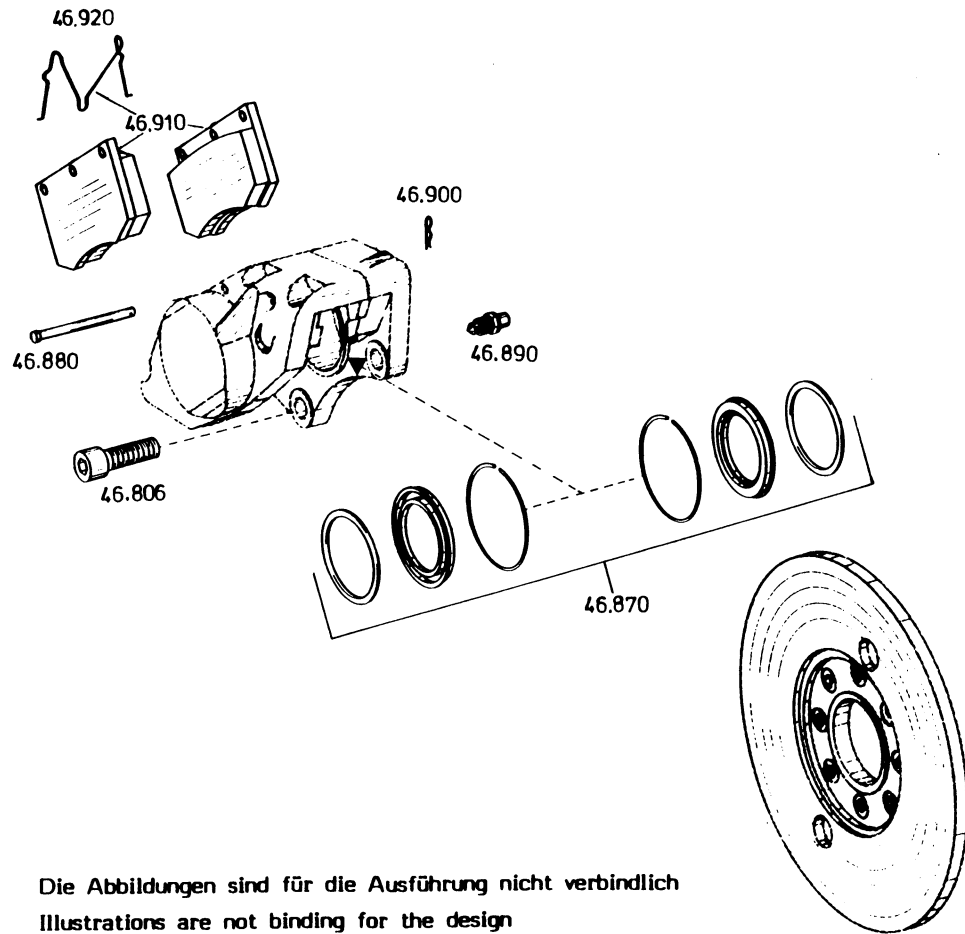

Die Abbildungen sind für die Ausführung nicht verbindlich  
 Illustrations are not binding for the design  
 Les illustrations ne sont pas obligatoires pour l'exécution

Gruppe 2052 146 VORDEFRADANTR.  
 Group FRONT WH.DRIVE  
 Groupe ENTRAIN.ROUE AV

Stückzahl nach Ausführung / Quantity per model /  
 Nombre par modèle  
 2071 060 21.11.86

Bild Nr. Fig. No. Fig. No.	Teilnummer Partnumber No. de pièce	Benennung	Description	Désignation	Anderung Modification Modification	alle all tous	023	024							
020	2052 346 493	GEHAUSE	HOUSING	CARTER			1	1							
030	0635 501 022	LAGERINNENRING	BEAR. INNER RING	BAGUE INT.ROULM			1	1							
040	0635 501 021	LAGERAUSSENRING	BEAR. OUTER RING	BAGUE EXT.ROULM			1	1							
050	0635 501 006	LAGERINNENRING	BEAR. INNER RING	BAGUE INT.ROULM			1	1							
070	0635 501 175	LAGERAUSSENRING	BEAR. OUTER RING	BAGUE EXT.ROULM			1	1							
080	2052 346 483	ABTRIEBSWELLE	OUTPUT SHAFT	ARBRE DE SORTIE			1	1							
090	2052 346 429 Z=39	STIRNPAD	SPUR GEAR	PIGNON CYLINDR.				1							
	2052 346 507 Z= 28	STIRNRAD	SPUR GEAR	PIGNON CYLINDR.			1								
100	2052 346 430 Z=20	ZAHNRADWELLE	GEAR SHAFT	ARBRE DE PIGNON				1							
	2052 346 509 Z= 18	ZAHNRADWELLE	GEAR SHAFT	ARBRE DE PIGNON			1								
110		DISTANZRING WAHLWEISE	SPACER RING OPTIONAL	BAGUE ENTRET. EN OPTION			1	1							
	0730 062 240 S=8,9	S=8,9					1	1							
	0730 062 241 S=8,7	S=8,7					1	1							
	0730 062 242 S=8,5	S=8,5					1	1							
	0730 062 243 S=8,4	S=8,4					1	1							
	0730 062 244 S=8,3	S=8,3					1	1							
	0730 062 245 S=8,2	S=8,2					1	1							
	0730 062 246 S=8,1	S=8,1					1	1							
120	0634 306 247 40X2 ZFN 744	O-RING	O-RING	JOINT TORIQUE			1	1							
130	2052 346 386	ABTRIEBSFLANSCH	OUTPUT FLANGE	BRIDE DE SORTIE			1	1							



Gruppe 2052 146 VORDERRADANTR.  
 Group FRONT WH.DRIVE  
 Groupe ENTRAIN.POUVE AV

Stückzahl nach Ausführung / Quantity per model /  
 Nombre par modèle  
 2071 060 21.11.86

Bild Nr. Fig. No. Fig. No.	Teilnummer Partnumber No. de pièce	Benennung	Description	Désignation	Änderung Modification Modification	alle all tous	023	024							
170	2049 346 096	SCHEIBE	WASHER	RONDELLE			1	1							
180	0631 308 026 5X12 DIN 1473	KERBSTIFT	GROOVED PIN	GOUP.CANNELEE			1	1							
190	0630 602 004 13 DIN 432	SICHERUNGSBLECH	TAB WASHER	TOLÉ-FREIN			1	1							
200	0636 016 155 M 12X28 DIN 933 10.9	6KT.SCHRAUBE	HEXAGON SCREW	VIS HEXAGONALE			1	1							
210	0750 117 068	ROLLENLAGER	ROLLER BEARING	ROULEM.A ROUL.			1	1							
220	0750 117 076	ROLLENLAGER	ROLLER BEARING	ROULEM.A ROUL.			1	1							
230		EINSTELLSCHEIBE WAHLWEISE	SHIM OPTIONAL	RONDELLE EN OPTION			1	1							
	0730 100 980 S=5,0	S=5,0					1	1							
	0730 100 981 S=4,5	S=4,5					1	1							
	0730 100 982 S=4,0	S=4,0					1	1							
	0730 100 983 S=3,5	S=3,5					1	1							
	0730 100 984 S=3,0	S=3,0					1	1							
	0730 100 985 S=2,5	S=2,5					1	1							
	0730 100 986 S=2,0	S=2,0					1	1							
260	2052 246 213	FEDERSAEULE	SET OF SPRINGS	COLONNE PESS.			1	1							
270	2052 346 352	DRUCKSTUECK	PRESSURE PIFCE	POUSSOIR			1	1							
280	0735 340 074	KUGELLAGER	BALL BEARING	ROULEM.A BILLES			1	1							

Gruppe 2052 146 VORDERRADANTR.  
 Group FRONT WH.DRIVE  
 Groupe ENTRAIN.ROUE AV

Stückzahl nach Ausführung / Quantity per model /  
 Nombre par modèle  
 2071 060 21.11.86

Bild Nr. Fig. No. Fig. No.	Teilnummer Partnumber No. de pièce	Benennung	Description	Désignation	Anderung Modification Modification	alle all tous	023	024								
290	0730 100 668 S=3,0	ABSTANDSCHEIBE	DISTANCE WASHER	DISQUE ENTRET.				1	1							
300	0630 501 044 65X2,5 DIN 471	SICHERUNGSRING	RETAINING RING	JONC D'ARRET				1	1							
310	2049 346 029	DRUCKRING	PRESSURE RING	PLAT.PRESSEUR				1	1							
320	2052 346 481	LAMELLENTRAEGER	DISC CARRIER	PORTE DISQUES				1	1							
330	2049 346 087	INNENLAMELLE	I.CLUTCH DISC	DISQUE INT.				6	6							
340	2052 246 270	AUSSENLAMELLE	O.CLUTCH DISC	DISQUE EXT.				6	6							
350	2049 346 033	DRUCKSCHEIBE	PRESSURE DISC	RONDELLE PRESS.				1	1							
370	0730 160 135	ZWISCHENROHR	INTERM.TUBE	TUBE INTERM.				1	1							
380	0730 100 708	GETEILTER RING	SPLIT RING	BAGUE DIVISEE				1	1							
390	2052 346 428	ANLAUFBUCHSE	THRUST BUSH	DOUILLE BUTEE				1	1							
410		AUSGL.SCHEIBE WAHLWEISE	SHIM OPTIONAL	RONDELLE EN OPTION				1	1							
	0730 102 103 S=2,8							1	1							
	0730 102 104 S=2,75							1	1							
	0730 102 105 S=2,7							1	1							
	0730 102 106 S=2,65							1	1							
	0730 102 060 S=2,6							1	1							
	0730 102 061 S=2,55							1	1							
	0730 102 062 S=2,5							1	1							
	0730 102 063 S=2,45							1	1							
	0730 102 064 S=2,4							1	1							
	0730 102 065 S=2,35							1	1							

Gruppe 2052 146 VORDERRADANTR.  
 Group FRONT WH.DRIVE  
 Groupe ENTRAIN.POUÉ AV

Stückzahl nach Ausführung / Quantity per model /  
 Nombre par modèle  
 2071 060 21.11.86

Bild Nr. Fig. No. Fig. No.	Teilnummer Partnumber No. de pièce	Benennung	Description	Désignation	Änderung Modification Modification	alle all tous										
						023	024									
	0730 102 066 S=2,3	S=2,3					1	1								
	0730 102 067 S=2,25	S=2,25					1	1								
	0730 102 068 S=2,2	S=2,2					1	1								
	0730 102 069 S=2,15	S=2,15					1	1								
	0730 102 070 S=2,1	S=2,1					1	1								
	0730 102 071 S=2,05	S=2,05					1	1								
	0730 102 072 S=2,0	S=2,0					1	1								
	0730 102 073 S=1,95	S=1,95					1	1								
	0730 102 074 S=1,9	S=1,9					1	1								
	0730 102 075 S=1,85	S=1,85					1	1								
	0730 102 700 S=1,8	S=1,8					1	1								
420	0501 303 304	GEHAUSEDECKEL	HOUSING COVER	COUVERCLE CART.			1									
430	2052 346 426 VORN	GEHAUSEDECKEL	HOUSING COVER	COUVERCLE CART.												
440	0634 309 220 58X80X10/12 7FN 132	WELLENDICHTRING	SHAFT SEAL	BAGUE ETANCH.			1	1								
470	2052 346 066 HINTEN	GEHAUSEDECKEL	HOUSING COVER	COUVERCLE CART.			1	1								
480	0636 015 110 M 10X20 DIN 933 8.8	6KT.SCHRAUBE	HEXAGON SCREW	VIS HEXAGONALE			8	8								
490	2052 346 440 Z=43/62	DOPPELSTIRNRAD	DOUBLE GEAR	PIGN.DROIT DOUB												
	2052 346 505 Z=44/62	DOPPELSTIRNRAD	DOUBLE GEAR	PIGN.DROIT DOUB			1									

Gruppe 2052 146 VORDERRADANTR.  
 Group FRONT WH.DRIVE  
 Groupe ENTRAIN.ROUE AV

Stückzahl nach Ausführung / Quantity per model /  
 Nombre par modèle

2071 060

21.11.86

Bild Nr. Fig. No. Fig. No.	Teilnummer Partnumber No. de pièce	Benennung	Description	Désignation	Änderung Modification Modification	alle all tous	023	024							
500	2052 246 222 Z=34	STIRNRAD	SPUR GEAR	PIGNON CYLINDR.				1							
	2052 246 228 Z=32	STIRNRAD	SPUR GEAR	PIGNON CYLINDR.			1								
530	0750 117 297	ROLLENLAGER	ROLLER BEARING	ROULEM.A ROUL.			1	1							
550	0750 117 043	ROLLENLAGER	ROLLER BEARING	ROULEM.A ROUL.			1	1							
570	2052 346 427	LAGERBOLZEN	BEARING BOLT	BOUL.DE PALIER			1	1							
580		RING WAHLWEISE	RING OPTIONAL	BAGUE EN OPTION			1	1							
	0730 062 214 S=6,7	S=6,7					1	1							
	0730 062 215 S=6,6	S=6,6					1	1							
	0730 062 216 S=6,5	S=6,5					1	1							
	0730 062 217 S=6,4	S=6,4					1	1							
	0730 062 218 S=6,3	S=6,3					1	1							
	0730 062 219 S=6,2	S=6,2					1	1							
	0730 062 220 S=6,1	S=6,1					1	1							
	0730 062 221 S=6,0	S=6,0					1	1							
	0730 062 222 S=5,9	S=5,9					1	1							
	0730 062 223 S=5,8	S=5,8					1	1							
590	0631 329 072 6X40 DIN 1481	SPANNSTIFT	SLOT.PIN	GOUPILLE ELAST.			1	1							
600	0631 329 145 3,5X40 DIN 1481	SPANNSTIFT	SLOT.PIN	GOUPILLE ELAST.			1	1							

Gruppe 2052 146 VORDERRADANTP.  
 Group FRONT WH.DRIVE  
 Groupe ENTRAIN.ROUE AV

Stückzahl nach Ausführung / Quantity per model /  
 Nombre par modèle  
 2071 060 21.11.86

Bild Nr. Fig. No. Fig. No.	Teilnummer Partnumber No. de pièce	Benennung	Description	Désignation	Änderung Modification Modification	Stückzahl nach Ausführung / Quantity per model / Nombre par modèle														
						alle all tous	023	024												
610	0630 361 029 30 DIN 443	VERSCHL.DECKEL	SEALING CAP	COUVERCLE			1	1												
620	2052 246 252	AUSRUECKGABEL	RELEASE FORK	FOURCHETTE DEBR			1	1												
630	0730 160 252	ROLLE	ROLLER	GALET			1	1												
640	0635 300 512	NADELKAEFIG	NEEDLE CAGE	CAGE A AIG.			2	2												
650	2049 346 044	BOLZEN	PIN	BOULON			1	1												
660	0630 501 008 12X1 DIN 471	SICHERUNGSPING	RETAINING RING	JONC D'ARRET			2	2												
670	0731 201 419	BOLZEN ANLAUFTEIL	PIN INTRODUCTION DATE	BOULON MOMENT DE DEMARRAGE	20292		2	2												
	0731 201 058	BOLZEN AUSLAUFTEIL	PIN TERMINATING DATE	BOULON MOMENT DE TERMNAISON	20292		2	2												
680	0636 301 006 M 18X1,5 DIN 906	VERSCHL.SCHR.	SCREW PLUG	VIS FERMETURE			2	2												
690	2052 346 323	NOCKEN	CAM	CAME			1	1												
700	0732 010 002	DREHFEDER	TORSION SPRING	RESSORT TORSION			1	1												
710	2049 346 070	SCHALTWELLE	G.SHIFT SHAFT	ARBRE CDE VIT.			1	1												
716	0631 501 412 R 6X4X36 DIN 6885	PASSFEDER	FITTING KEY	CLAVETTE			1	1												
720	0635 303 050	NADELHUELSE	NEEDLE SLEEVE	DOUILLE A AIG.			2	2												
726	0631 329 158 3X32 DIN 1481	SPANNSTIFT	SLOT.PIN	GOUPILLE ELAST.			1	1												

Gruppe 2052 146 VORDERRADANTR.  
 Group FRONT WH.DRIVE  
 Groupe ENTRAIN.ROUE AV

Stückzahl nach Ausführung / Quantity per model /  
 Nombre par modèle  
 2071 060 21.11.86

Bild Nr. Fig. No. Fig. No.	Teilnummer Partnumber No. de pièce	Benennung	Description	Désignation	Änderung Modification Modification	alle all tous	023	024							
750	0634 300 229 20X30X7 B ZFN 132	WELLENDICHTRING	SHAFT SEAL	BAGUE FTANCH.			1	1							
770	2052 346 324	DECKEL	COVER	COUVERCLE			1	1							
776	0636 015 060 M 8X12 DIN 933 8.8	6KT.SCHRAUBE	HEXAGON SCREW	VIS HEXAGONALE			4	4							
786	0631 306 081 12M6X30 ZFN 6	ZYLINDERSTIFT	CYLINDRICAL PIN	GROUPE CYL.			2	2							
790	0636 016 015 M 12X35 DIN 933 8.8	6KT.SCHRAUBE	HEXAGON SCREW	VIS HEXAGONALE			11	11							
796	2052 346 468	BREMSSCHEIBE	BRAKE DISC	DISQUE DE FREIN				1							
806	0636 101 196 M 12X35 DIN 912 10.9	ZYL.SCHRAUBE	CAP SCREW	VIS TETE CYL.				2							
810	0636 020 004 M 10X1X40 DIN 960 10.9	6KT.SCHRAUBE	HEXAGON SCREW	VIS HEXAGONALE				8							
	0636 010 244 M 10X80 DIN 931 10.9	6KT.SCHRAUBE	HEXAGON SCREW	VIS HEXAGONALE			8								
816	0637 011 534 M 10X1	SICHERGS.MUTTER	LOCKING NUT	ECROU- FREIN				8							
	0637 011 577 M 10	SICHERGS.MUTTER	LOCKING NUT	ECROU- FREIN			8								

Gruppe 2052 146 VORDERRADANTR.  
 Group FRONT WH.DRIVE  
 Groupe ENTRAIN.ROUE AV

Stückzahl nach Ausführung / Quantity per model /  
 Nombre par modèle  
 2071 060 21.11.86

Bild Nr. Fig. No. Fig. No.	Teilnummer Partnumber No. de pièce	Benennung	Description	Désignation	Änderung Modification Modification	alle all tous															
						023	024														
820	0636 015 166 M 10X25 DIN 933 10.9	6KT.SCHRAUBE	HEXAGON SCREW	VIS HEXAGONALE			8	6													
826	0636 101 100 M 10X30 DIN 912 10.9	ZYL.SCHRAUBE	CAP SCREW	VIS TETE CYL.					1												
830	0636 102 094 M 10X22 DIN 6912 10.9	ZYL.SCHRAUBE	CAP SCREW	VIS TETE CYL.					1												
840	0501 305 521	HEBEL	LEVER	LEVIER			1	1													
846	0631 320 086 8X40 DIN 1481	SPANNSTIFT	SLOT.PIN	GOUPILLE ELAST.			1	1													
850	0631 320 057 5X40 DIN 1481	SPANNSTIFT	SLOT.PIN	GOUPILLE ELAST.			1	1													
860	0636 101 343 M 16X1,5X45 DIN 912 10.9	ZYL.SCHRAUBE	CAP SCREW	VIS TETE CYL.			2														
865	0501 308 305	BREMSSCHEIBE	BRAKE DISC	DISQUE DE FREIN			1														
868	0501 203 783	ENTLUEFT.VENTIL	VENT VALVE	SOUP.PURGE AIR			1														

Gruppe 2052 146 VORDERR.ANTRIEB  
 Group FRONT WHEEL'DRIVE  
 Groupe COMMANDE ROUES AV.

Stückzahl nach Ausführung / Quantity per model /  
 Nombre par modèle  
 2071 060 21.11.86

Bild Nr. Fig. No. Fig. No.	Teilnummer Partnumber No. de pièce	Benennung	Description	Désignation	Änderung Modification Modification	alle all tous	023	024							
		<u>SCHEIBENBREMSE</u> <u>(FESTSATTELbremse)</u>	<u>DISK BRAKE</u> <u>(FIXED -CALIPER</u> <u>BRAKE)</u>	<u>FREIN A DISQUE</u> <u>(FREIN ETRIER FIXE)</u>											
870- 920	0501 001 792	SCHEIBENBREMSE KPL. TYPE - M 16 MZ	DISK BRAKE ASS. TYPE - M 16 MZ	FREIN A DISQUE COMPL. TYPE - M 16 MZ				1							
870	0501 298 001	DICHTUNGSSATZ KPL. BESTEHEND AUS:	SET OF SEALS ASS. CONSISTING OF:	JEU DE JOINT COMPL. COMPOSE DE:				1							
	0501 305 648	DICHTRING	SEAL RING	RONDELLE D'ETANCHEITE				2							
	0501 305 650	SCHUTZKAPPE	PROTECTION CAP	CAPUCHON				2							
	0501 305 651	HALTERING	RETAINING RING	ANNEAU DE RETENUE				2							
	0501 305 653	STAUBKAPPE	DUST CAP	CAPUCHON				1							
880	0501 305 639	HALTESTIFT	RETAINER PIN	COUPILLE D'ARRET				2							
890	0501 298 939	ENTLÜFTER KPL.	BREATHER ASS.	RENIFLARD COMPL.				1							
900	0501 305 640	SICHERUNGSÖSE	SPRING CLIP	RESSORT D'ARRET				2							
910	0501 298 003	BELAGSATZ KPL. BESTEHEND AUS:	LINING SET ASS. CONSISTING OF:	JEU DE GARNITURE CPL. COMPOSE DE:				1							
	0501 307 595	BREMSBELAG KPL.	BRAKE LINING ASS.	GARNITURE COMPL.				2							
	0501 307 597	FEDER	SPRING	RESSORT				1							
920	0501 307 597	FEDER (AUCH EINZELN LIE- FERBAR)	SPRING (CAN ALSO BE SUPPLIED AS A SINGLE PART)	RESSORT (PEUT ETRE AUSSI FOURNIE COMME PIECE DEFACHEE)				1							
		<u>SCHREIBENBREMSE</u> <u>(FESTSATTELbremse)</u>	<u>DISK BRAKE</u> <u>(FIXED-CALIPER</u> <u>BRAKE)</u>	<u>FREIN A DISQUE</u> <u>(FREIN ETRIER FIXE)</u>											
950- 970	0501 002 067	SCHEIBENBREMSE KPL.	DISK BRAKE ASS.	FREIN A DISQUE COMPL.				1							
950	0501 298 026	DICHTUNGSSATZ KPL. BESTEHEND AUS:	SET OF SEALS ASS. CONSISTING OF:	JEU DE JOINT COMPL. COMPOSE DE:				1							
	0501 305 118	DICHTUNG	GASKET	JOINT				2							
	0501 305 120	SCHUTZKAPPE	DUST CAP	CAPUCHON				2							



Gruppe 2052 146 VORDERR.ANTRIEB  
 Group FRONT WHEEL'DRIVE  
 Groupe COMMANDE ROUES AV.

Stückzahl nach Ausführung / Quantity per model /  
 Nombre par modèle

2071 060

21.11.86

Bild Nr. Fig. No. Fig. No.	Teilnummer Partnumber No. de pièce	Benennung	Description	Désignation	Änderung Modification Modification	alle all tous												
						023	024											
960	0501 298 025	BELAGSATZ KPL.	LINING SET ASS.	JEU DE GARNITURE CPL.			1											
		BESTEHEND AUS:	CONSISTING OF:	COMPOSE DE:			1											
	0501 305 661	BREMSBELAG OHNE WARNANZEIGE	BRAKE LINING WITHOUT WARNING INDICATOR	GARNITURE DE FREIN SANS INDICATEUR AVERTISSEMENT			1											
	0501 203 734	BREMSBELAG MIT WARNANZEIGE	BRAKE LINING WITH WARNING INDICATOR	GARNITURE DE FREIN AVEC INDICATEUR AVERTISSEMENT			2											
	0501 306 435	ZWISCHENBLECH	SHIM	TOLE INTERMEDIAIRE			2											
	0501 306 436	SPLINT	COTTER PIN	GOUPILLE FENDUE			1											
	0501 203 529	FEDER	SPRING	RESSORT														
970	0501 306 435	ZWISCHENBLECH (AUCH EINZELN LIE- FERBAR)	SHIM (CAN ALSO BE SUPPLIED AS A SINGLE PART)	TOLE INTERMEDIAIRE (PEUT ETRE AUSSI FOURNIE COMME PIECE DEFACHEE)			2											

Gruppe  
Group  
Groupe

2052 114

KRIECHGANG  
CREPP GEAR  
RED.VIT RAMPANTE

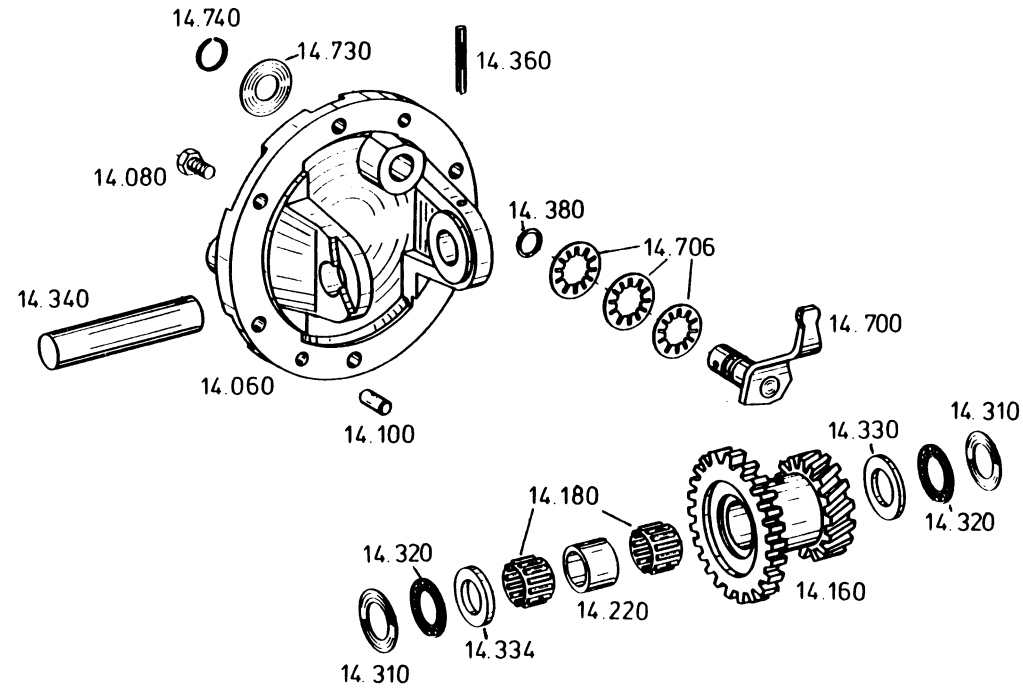

Die Abbildungen sind für die Ausführung nicht verbindlich  
Illustrations are not binding for the design  
Les illustrations ne sont pas obligatoires pour l'exécution

Gruppe 2052 114 KRIECHGANG Group CREEP SPEED RANGE Groupe VITESSE LENTE					Stückzahl nach Ausführung / Quantity per model / Nombre par modèle 2052 114 21.11.86											
Bild Nr. Fig. No. Fig. No.	Teilnummer Partnumber No. de pièce	Benennung	Description	Désignation	Änderung Modification Modification	alle all tous	042									
060	2052 314 127	LAGERDECKEL	BEARING COVER	CHABEAU DE PALIER			1									
080	0636 015 115 M 10 x 22 DIN 933 - 10.9	SECHSKANTSCHRAUBE	HEX. HEAD SCREW	VIS A SIX PANS			6									
100	0631 306 074 10 M 6 x 24 ZFN-6	ZYLINDERSTIFT	DOWEL	GOUJON CYLINDRIQUE			2									
160	2052 314 157	DOPPELRAD	DUAL GEAR	PIGNON DOUBLE			1									
180	0750 115 061	NADELKRANZ	NEEDLE CAGE	CAGE A AIGUILLES			2									
220	0730 062 582	ABSTANDSROHR	SPACER SLEEVE	ENTRETOISE			1									
310	0635 290 003 AS 2542 25 x 42 x 1	AXIAL-SCHEIBE	AXIAL WASHER	RONDELLE DE BUTEE			2									
320	0635 302 011	AXIAL-NADELKAEFIG	AXIAL NEEDLE CAGE	CAGE A AIGUILLES AXIA.			2									
330		SCHEIBE WAHLWEISE:	WASHER OPTIONAL:	RONDELLE EN OPTION:			1									
	0730 105 166	5,15					1									
	0730 105 167	5,2					1									
	0730 105 168	5,25					1									
	0730 105 169	5,35					1									
	0730 105 170	5,4					1									
	0730 105 171	5,5					1									
	0730 105 172	5,6					1									
	0730 105 173	5,8					1									
334	0730 105 175	SCHEIBE 6,2	WASHER	RONDELLE			1									
340	2052 314 136	BOLZEN	PIN	BOULON			1									
360	0631 329 074 6 x 50 DIN 1481	SPANNSTIFT	ROLL PIN	GOUPILLE DE SERRAGE			1									
380	0634 306 015 15,3 x 2,4 ZFN-744	O-RING	O-RING	JOINT TORIQUE			1									
700	2052.214 060	SCHALTHEBEL KPL.	CONTROL LEVER ASS.	LEVIER DE COMMANDE COMPL.			1									

Gruppe 2052 114 KRIECHGANG  
 Group CREEP SPEED RANGE  
 Groupe VITESSE LENTE

Stückzahl nach Ausführung / Quantity per model /  
 Nombre par modèle

2052 114

21.11.86

Bild Nr. Fig. No. Fig. No.	Teilnummer Partnumber No. de pièce	Benennung	Description	Désignation	Anderung Modification Modification	alle all tous	042									
706	0632 051 016 36,6 x 20,4 x 0,4	TELLERFEDER	CUP SPRING	RESSORT BELLEVILLE			3									
730	0730 150 185	SCHEIBE 1,0	WASHER	RONDELLE			1									
740	0630 513 090 SW 20	SPRENGRING	SNAP RING	ANNEAU DE RETENUE			1									



GRUPPE 2052 114  
GROUP  
GROUPE

SUPERKRIECHGANG  
SUPER CREEP SPEED RANGE  
VITESSE TRES LENTE

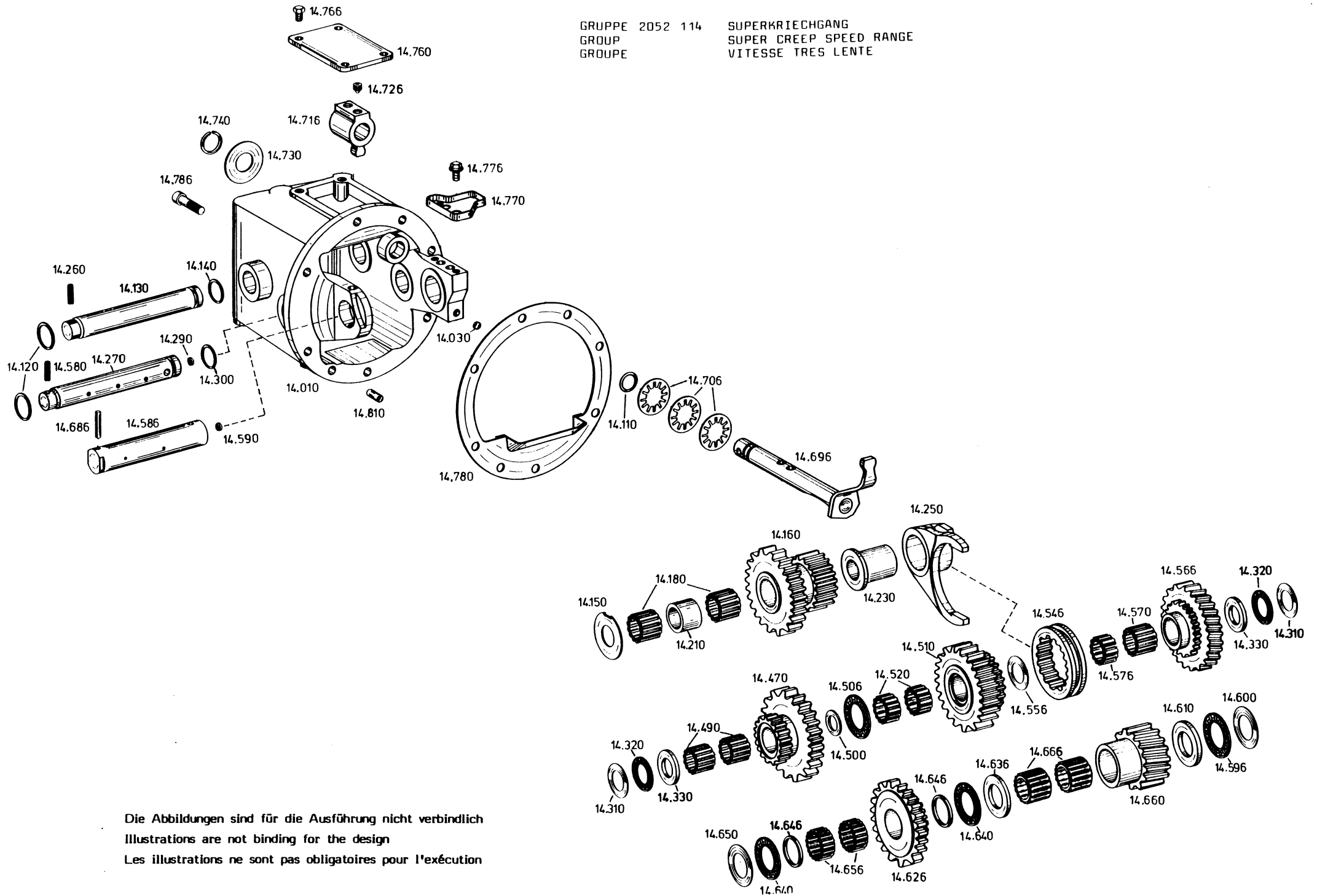

Die Abbildungen sind für die Ausführung nicht verbindlich  
Illustrations are not binding for the design  
Les illustrations ne sont pas obligatoires pour l'exécution

Gruppe 2052 114 SUPERKRIECHGANG Group SUPER CREEP SPEED VANGE Groupe VITESSE TRES LENTE			Stückzahl nach Ausführung / Quantity per model / Nombre par modèle												
			2052 114				21.11.86								
Bild Nr. Fig. No. Fig. No.	Teilnummer Partnumber No. de pièce	Benennung	Description	Désignation	Änderung Modification Modification	alle all tous	040								
010	2052 314 152	GEHÄUSE	HOUSING	CARTER		1									
030	0630 361 036 8 DIN 443	VERSCHLUSSDECKEL	SEALING COVER	COUVERCLE DE FERMETURE		1									
110	0634 306 015 15,3 x 2,4 ZFN-744	O-RING	O-SEAL	BAGUE TORIQUE		1									
120	0634 303 259 25 x 3 ZFN-744	O-RING	O-SEAL	BAGUE TORIQUE		2									
130	2052 314 131	LAGERBOLZEN	KING PIN	PIVOT FUSEE		1									
140	0634 306 204 19 x 3 ZFN-744	O-RING	O-SEAL	BAGUE TORIQUE		1									
150	0730 103 041	ANLAUFSCHLEIBE	THRUST WASHER	RONDELLE DE BUTEE		1									
160	2052 314 106	DOPPELRAD	DOUBLE GEAR	ROUE JUMEE		1									
180	0750 115 061	NADELKRANZ	NEEDLE CAGE	CAGE AIGUILLES		2									
210	0730 161 045	BUCHSE	SLEEVE	DOUILLE		1									
230	2052 314 119	FUEHRUNGSBUCHSE	GUIDE SLEEVE	DOUILLE GUIDAGE		1									
250	2052 314 123	SCHALTGABEL	SHIFTER FORK	FOURCHETTE VITESSES		1									
260	0631 329 072 6 x 40 DIN 1481	SPANNSTIFT	CLAMPING PIN	CHEVILLE SERRAGE		1									
270	2052 314 130	LAGERBOLZEN	KING PIN	PIVOT FUSEE		1									
290	0630 361 036 8 DIN 443	VERSCHLUSSDECKEL	SEALING COVER	COUVERCLE DE FERMENT.		1									
300	0634 306 204 19 x 3 ZFN-744	O-RING	O-SEAL	BAGUE TORIQUE		1									
310	0635 290 003 AS 2542 25 x 42 x 1	AXIALSCHEIBE	AXIAL WASHER	RONDELLE AXIALE		2									
320	0635 302 011 AXK 2542	AXIALNADELKAEFIG	AX.NEEDLE CAGE	CAGE A AGUILLES AX.		2									

<b>Gruppe</b>	2052 114	SUPERKRIECHGANG	Stückzahl nach Ausführung / Quantity per model /					
<b>Group</b>		SUPER CREEP SPEED RANGE	Nombre par modèle					
<b>Groupe</b>		VITESSE TRES LENTE	2052 114	21.11.86				

Bild Nr. Fig. No. Fig. No.	Teilnummer Partnumber No. de pièce	Benennung	Description	Désignation	Anderung Modification Modification	alle all tous	040								
330		SCHEIBE WAHLWEISE:	DISK OPTIONAL:	DISQUE EN OPTION:			2								
	0730 104 125	S=3,0					2								
	0730 104 126	S=3,05					2								
	0730 104 127	S=3,15					2								
	0730 104 128	S=3,2					2								
	0730 104 129	S=3,25					2								
	0730 104 130	S=3,35					2								
	0730 104 131	S=3,4					2								
	0730 104 132	S=3,5					2								
	0730 104 133	S=3,6					2								
	0730 104 134	S=3,8					2								
	0730 104 135	S=4,0					2								
	0730 104 136	S=4,2					2								
470	2052 314 148	DOPPELRAD	DOUBLE GEAR	ROUE JUMEELE			1								
490	0635 300 096	NADELKRANZ	NEEDLE CAGE	CAGE AIGUILLES			2								
500	0730 104 316	SCHEIBE	DISK	DISQUE			1								
506	0635 302 034	AXIALNADELKAEFIG	AX.NEEDLE CAGE	CAGE A AIGUILLES AX.			1								
510	2052 314 134	STIRNRAD	SPUR GEAR	ENGRENAGE DROIT			1								
520	0735 320 545	NADELKAEFIG	NEEDLE CAGE	CAGE AIGUILLES			2								
546	2052 314 108	SCHIEBEMUFFE	SLIDING SLEEVE	MANCHON BALADEUR			1								
556	0635 290 003 AS 2542 25 x 42 x 1	AXIALSCHEIBE	AXIAL WASHER	RONDELLE AXIALE			1								
566	2052 314 109	STIRNRAD	SPUR GEAR	ENGRENAGE DROIT			1								
570	0750 115 061	NADELKRANZ	NEEDLE CAGE	CAGE AIGUILLES			1								
576	0735 320 545	NADELKAEFIG	NEEDLE CAGE	CAGE AIGUILLES			1								
580	0631 329 072 6 x 40 DIN 1481	SPANNSTIFT	CLAMPING PIN	CHEVILLE SERRAGE			1								
586	2052 314 149	LAGERBOLZEN	KING PIN	PIVOT FUSEE			1								
590	0630 361 036 8 DIN 443	VERSCHLUSSDECKEL	SEALING COVER	COUVERCLE DE FERMET.			1								



<b>Gruppe</b>	2052 114	SUPERKRIECHGANG	Stückzahl nach Ausführung / Quantity per model /
<b>Group</b>		SUPER CREEP SPEED RANGE	Nombre par modèle
<b>Groupe</b>		VITESSE TRES LENTE	2052 114
			21.11.86

Bild Nr. Fig. No. Fig. No.	Teilnummer Partnumber No. de pièce	Benennung	Description	Désignation	Änderung Modification Modification	alle all tous	040									
596	0635 302 032	AXIALNADELKAEFIG	AX.NEEDLE CAGE	CAGE A AGUILLES AX.			1									
600	0635 290 007 AS 3047 30 x 47 x 1	AXIALSCHEIBE	AXIAL WASHER	RONDELLE AXIALE			1									
610		LAUFSCHEIBE WAHLWEISE:	THRUST WASHER OPTIONAL:	RONDELLE DE BUTEE EN OPTION:			1									
	0730 104 234	S=3,0					1									
	0730 104 235	S=3,05					1									
	0730 104 236	S=3,15					1									
	0730 104 237	S=3,2					1									
	0730 104 238	S=3,25					1									
	0730 104 239	S=3,35					1									
	0730 104 240	S=2,4					1									
	0730 104 241	S=3,5					1									
626	2052 214 083	DOPPELRAD	DOUBLE GEAR	ROUE JUMELLE			1									
636	0730 104 469	SCHEIBE	DISK	DISQUE			1									
640	0635 302 019	AXIALNADELKAEFIG	AX. NEEDLE CAGE	CAGE A AGUILLES AX.			2									
646	0730 104 467	SCHEIBE	DISK	DISQUE			2									
650	0730 104 470	SCHEIBE	DISK	DISQUE			1									
656		NADELKAEFIG WAHLWEISE:	NEEDLE CAGE OPTIONAL:	CAGE AIGUILLES EN OPTION:			2									
	0735 320 546						2									
	0735 320 547						2									
660	2052 314 110	STIRNRAD	SPUR GEAR	ENGRENAGE DROIT			1									
666	0735 358 093	NADELKAEFIG	NEEDLE CAGE	CAGE AIGUILLES			2									
686	0631 329 116 6 x 60 DIN 1481	SPANNSTIFT	CLAMPING PIN	CHEVILLE SERRAGE			1									
696	2052 214 080	SCHALTWELLE	G.SHIFT SHAFT	ARBRE CDE VIT.			1									
706	0632 051 016 36,6x20,4x0,4	TELLERFEDER	CUP SPRING	RESSORT BELLEVILLE			3									
716	2052 314 115	SCHALTNÖCKEN	SHIFT CAM	CAME DE COMMANDE			1									
726	1238 306 065	GEWINDESTIFT	SET SCREW	GOUPILLE FILETEE			2									

Gruppe 2052 114 SUPERKRIECHGANG  
 Group SUPER CREEP SPEED RANGE  
 Groupe VITESSE TRES LENTE

Stückzahl nach Ausführung / Quantity per model /  
 Nombre par modèle

2052 114

21.11.86

Bild Nr. Fig. No. Fig. No.	Teilnummer Partnumber No. de pièce	Benennung	Description	Désignation	Anderung Modification Modification	alle all tous	040									
730	0730 150 185	SCHEIBE	DISK	DISQUE			1									
740	0630 513 090 SW 20	SPRENGRING	SNAP RING	ANNEAU RETENUE			1									
760	2052 314 122	DECKEL	COVER	COUVERCLE			1									
766	0636 015 147 M 10 x 18 DIN 933 - 8.8	SECHSKANTSCHRAUBE	HEX.HEAD SHREW	VIS A SIX PANS			4									
770	2052 314 135	OELWANNE	OIL PAN	CARTER D HUILE			1									
776	0636 031 054 M 6 x 12	SICHERUNGSSCHRAUBE	LOCK SCREW	VIS SECURITE			2									
780	2052 214 078	OELFANGBLECH	OIL SLINGER	DEFLECTEUR D HUILE			1									
786	0636 101 047 M 10 x 22 DIN 912 - 8.8	ZYLINDERSCHRAUBE	SOCKET HEAD SCREW	VIS TETE CYLINDRIQUE			6									
810	0631 306 072 10 M 6 x 18 ZFN-6	ZYLINDERSTIFT	DOWEL	GOUJON			2									