

**ERSATZTEIL-LISTE
SPARE PARTS LIST
LISTE DES PIECES DE
RECHANCE**

Änderungen vorbehalten!
With the reserve of modifications
Modifications reserves!

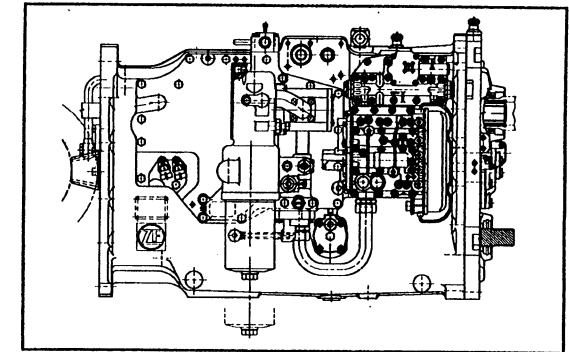

T-7300

**ZF-SCHLEPPERTRIEBWERK
ZF-TRACTOR TRANSMISSION
ENSEMBLE BOITE-PONT ZF
POUR TRACTEURS AGRICOLES**

Stückliste Nr.: / Parts list No.: / Liste de pieces No.: 2094 001 019/020/021



ZF Passau GmbH
Donaustr. 25-71 94034 Passau

Ausgabe: 05.93

LIEFERBEDINGUNGEN FÜR ERSATZTEILE

Bestellungen auf Ersatzteile sollen stets folgende Angaben enthalten, um eine richtige und schnelle Lieferung zu sichern:

1. **Type**
2. **Aggregatnummer**
3. **Stücklistennummer**
4. **Fabrikat und Typw des Fahrzeuges**
5. **Benennung des Ersatzteils:** Wie in der Ersatzteilliste aufgeführt.
6. **Ersatzteil-Nummer:** Siehe Ersatzteilliste, Nummer ist größtenteils auch im Teil eingeschlagen.
7. **Versandart:** Post, Luftpost, Express, Fracht, Eilgut, Stückgut; fehlen Angaben, so geschieht der Versand nach unserem Ermessen.

} Angaben siehe Typenschild
bzw. eingeschlagene Zahlen

Telefonische oder telegrafische Bestellungen bitten wir schriftlich zu bestätigen.

Der Versand geschieht auf Gefahr des Käufers, auch dann, wenn die Ersatzteile nicht berechnet werden.

Zahlungsbedingungen: Die Kosten für Ersatzteile werden durch Nachnahme erhoben.

DELIVERY CONDITIONS FOR SPARE PARTS

In order to secure a correct and prompt delivery, all spare part orders should be compiled as follows:

1. **Type**
2. **Serial-No.**
3. **Parts list No.**
4. **Trade mark and type of vehicle:**
5. **Denomination of spare part:** according to the indication in the parts list.
6. **Spare parts No.:** see spare parts list, the number is very often engraved on the part.
7. **Way of delivery:** mail, air mail, express delivery, ordinary freight, express goods, cargo; if no indication is made, the transportation will be realized to our opinion.

} see indications on type
identification plate
resp. engraved part number

We kindly ask you to confirm orders given by telephone call or telegramme.

Even if the spare parts are free of charge the delivery will be to the buyers obligation.

Terms: Cash on delivery.

CONDITIONS DE LIVRAISON POUR LES PIÈCES DE RECHANGE

Afin de vous assurer une prompte et correcte livraison, les commandes des pièces de rechange doivent être rédigées dans la façon suivante:

1. **Type**
2. **No. de la série**
3. **No, de la liste de pièces**
4. **Marque et type de véhicule**
5. **Dénomination de la pièce de rechange** come indiqué sur la liste des pièces de rechange.
6. **No. de la pièce:** v. liste des pièces de rechange, la plupart du temps, le nombre vient aussi poinçonné sur la pièce.
7. **Mode d'expédition:** ar poste, poste aérienne, expres, en grande vitesse, en colis; où il n'y a pas des spécifications, l'expédition sera effectuée à notre choix.

} v. les indications sur la plaque
de type, resp. les chiffres poinçonnées

Nous vous prions de nous confirmer par écrit les commandes données par téléphone ou télégramme.

La marchandise sera toujours expédiée aux risques de l'acheteur, même dans le cas où les pièces de rechange ne viennent pas facturées.

Conditions de payment: contre remboursement.

INHALTSVERZEICHNIS	TABLE OF CONTENTS	TABLE DES MATIERES	GRUPPE	SEITE
			GROUP	PAGE
			GROUPE	PAGE
BETR. BREMSE	SERVICE BRAKE	FREIN DE SERVICE	124	39
FAHRKUPPLUNG	DRIVE CLUTCH	EMBRAYAGE	113	21
FILTER	FILTER	FILTRE	209	77
GETRIEBEGEHÄUSE	GEARBOX HOUSING	CARTER DE BOITE	101	17
HAUPTWELLE	MAIN SHAFT	ARBRE PRINCIPAL	104	31
HYDR. SCHALTUNG	GEARSH. SYST. HYDR.	CHANGEMT. VIT HYDR.	177	57
KRIECHGANG	CRAWLER	VIT. EXTRA-LENTE	114	25
LASTSCHALTGRUPPE	POWER SHIFT GROUP	CH. DE VIT. SOUS CHARGE	159	11
LOSTEILE	LOOSE PARTS	PCES. DETACHEES	199	79
OELVERSORGUNG	OIL SUPPLY	ALIMENT. HUILE	136	67
OELVERSORGUNG	OIL SUPPLY	ALIMENT HUILE	147	69
PUMPENANTRIEB	PUMP DRIVE	ENTRAIN. POMPE	122	61
SCHALTTEILE	GEARSHIFT PARTS	ELTS PASS. VIT.	192	75
SCHALTUNG	GEARSHIFT SYST.	CHANGEMT. VIT.	106	43
SCHALTUNG	GEARSHIFT SYST	CHANGEMT. VIT.	152	50
SPLITGRUPPE	SPLITTER GROUP	SPLITTER	168	3
VORDERRADANTRIEB	FRONT WH. DRIVE	ENTAIN. ROUE AV	146	35
VORGELEGEWELLE	LAYSHAFT	ARBRE INTERM.	103	27
ZAPFWELLE	P. T. O. SHAFT	PRISE DE FORCE	110	9

Gruppe 2094 168 SPLITGRUPPE
 Group
 Groupe

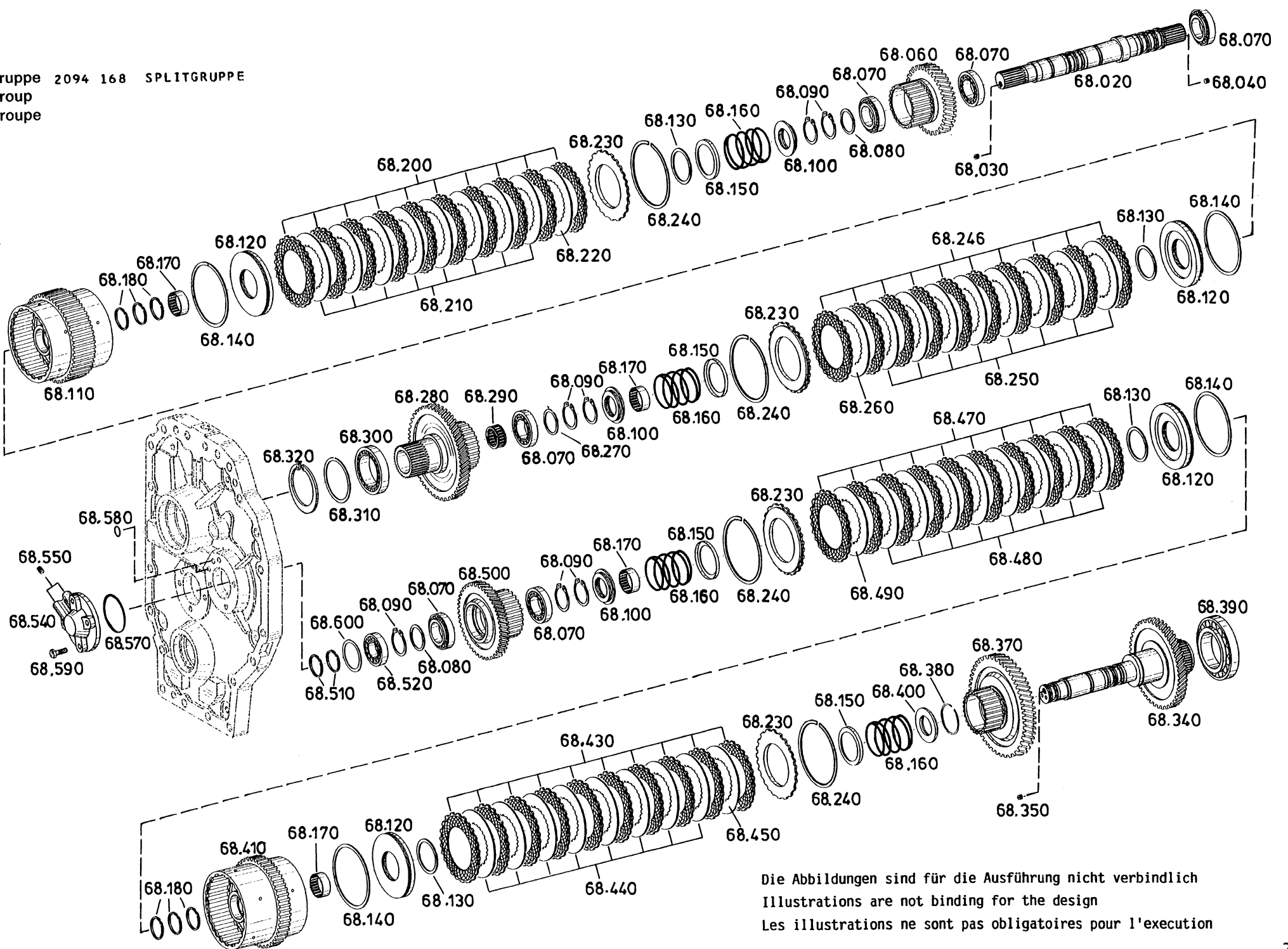

Die Abbildungen sind für die Ausführung nicht verbindlich
 Illustrations are not binding for the design
 Les illustrations ne sont pas obligatoires pour l'exécution

Gruppe 2094 168 SPLITGRUPPE
 Group
 Groupe

Stückzahl nach Ausführung / Quantity per model /
 Nombre par modèle
 2094 001 19.05.93

Bild Nr. Fig. No. Fig. No.	Teilnummer Partnumber No. de pièce	Benennung	Description	Désignation	Änderung Modification Modification	Stückzahl nach Ausführung / Quantity per model / Nombre par modèle														
						alle all tous	019	020	021											
020	2094 359 031	ANTRIEBSWELLE	INPUT SHAFT	ARBRE D'ENTREE			1	1	1											
030	0731 607 026	BLENDE	ORIFICE	AJUTAGE			2	2	2											
040	0631 610 010 M 10 X 8 DIN 913 8.8	GEWINDESTIFT	SET SCREW	GOUJON FILETE			2	2	2											
060	2094 359 034 Z=41	STIRNRAD	SPUR GEAR	PIGNON CYLINDR.			1	1	1											
070	0750 117 504	ROLLENLAGER	ROLLER BEARING	ROULEM.A ROUL.			6	6	6											
080		AUSGL.SCHEIBE WAHLWEISE	SHIM OPTIONAL	RONDELLE EN OPTION																
	0730 107 826	S=1,0					2	2	2											
	0730 107 827	S=1,3					2	2	2											
	0730 107 828	S=1,35					2	2	2											
	0730 107 829	S=1,4					2	2	2											
	0730 107 830	S=1,45					2	2	2											
	0730 107 831	S=1,5					2	2	2											
	0730 107 832	S=1,55					2	2	2											
	0730 107 833	S=1,6					2	2	2											
	0730 107 834	S=1,65					2	2	2											
	0730 107 835	S=1,7					2	2	2											
	0730 107 836	S=1,75					2	2	2											
	0730 107 837	S=1,8					2	2	2											
090	0630 531 050 40X2,5 DIN 471	SICHERUNGSRING	RETAINING RING	JONC D'ARRET			7	7	7											
100	0735 298 130	NADELLAGER	NEEDLE BEARING	ROULEMT A AIG.			3	3	3											
110	2094 259 019	LAMELLENTRAEGER	DISC CARRIER	PORTE DISQUES			1	1	1											
120	2094 359 004	KOLBEN	PISTON	PISTON			4	4	4											
130	0750 112 140	PROFILDICHTRING	PROF.SEAL RING	JOINT PROFILE			4	4	4											
140	0734 307 183	PROFILDICHTRING	PROF.SEAL RING	JOINT PROFILE			4	4	4											
150	4642 308 083	FUEHRUNGSRING	GUIDE RING	BAGUE GUIDAGE			4	4	4											

Gruppe 2094 168 SPLITGRUPPE
Group
Groupe

Stückzahl nach Ausführung / Quantity per model /
Nombre par modèle

2094 001

19.05.93

Bild Nr. Fig. No. Fig. No.	Teilnummer Partnumber No. de pièce	Benennung	Description	Désignation	Änderung Modification Modification	Stückzahl nach Ausführung / Quantity per model / Nombre par modèle														
						alle all tous	019	020	021											
160	0732 041 183	DRUCKFEDER	COMPR. SPRING	RESSORT PRESS.			4	4	4											
170	0750 115 365	NADELHUELSE	NEEDLE SLEEVE	DOUILLE A AIG.			4	4	4											
180	0634 402 541 40 X 2 DIN 34118	R-RING SH P KA	PISTON RING	SEGMENT			10	10	10											
200	0501 313 598	AUSSENLAMELLE	O.CLUTCH DISC	DISQUE EXT.			10	10	10											
210	4642 308 332	INNENLAMELLE	I.CLUTCH DISC	DISQUE INT.			8	8	8											
220		INNENLAMELLE WAHLWEISE	I.CLUTCH DISC OPTIONAL	DISQUE INT. EN OPTION																
	4642 308 332	S=2,0					1	1	1											
	4642 308 330	S=1,5					1	1	1											
	4642 308 331	S=2,5					1	1	1											
230	4642 308 185	ENDSCHEIBE	END SHIM	RONDELLE			4	4	4											
240	0730 513 180	SPRENGRING	SNAP RING	CIRCLIP			4	4	4											
246	0501 313 598	AUSSENLAMELLE	O.CLUTCH DISC	DISQUE EXT.			10	10	10											
250	4642 308 332	INNENLAMELLE	I.CLUTCH DISC	DISQUE INT.			8	8	8											
260		INNENLAMELLE WAHLWEISE	I.CLUTCH DISC OPTIONAL	DISQUE INT. EN OPTION																
	4642 308 332	S=2,0					1	1	1											
	4642 308 330	S=1,5					1	1	1											
	4642 308 331	S=2,5					1	1	1											
270	0730 107 826	AUSGL.SCHEIBE	SHIM	RONDELLE			1	1	1											
280	2094 359 030 Z=59	ANTRIEBSRAD	INPUT GEAR	ROUE MOTRICE			1	1	1											
290	0750 115 361	NADELKRANZ	NEEDLE CAGE	CAGE A AIG.			1	1	1											
300	0750 117 505	ROLLENLAGER	ROLLER BEARING	ROULEM.A ROUL.			1	1	1											
310		AUSGL.SCHEIBE WAHLWEISE	SHIM OPTIONAL	RONDELLE EN OPTION																
	0730 107 839	S=1,2					1	1	1											
	0730 107 840	S=1,25					1	1	1											

Gruppe 2094 168 SPLITGRUPPE

Group
Groupe

Stückzahl nach Ausführung / Quantity per model /
Nombre par modèle

2094 001

19.05.93

Bild Nr. Fig. No. Fig. No.	Teilnummer Partnumber No. de pièce	Benennung	Description	Désignation	Änderung Modification Modification	Stückzahl nach Ausführung / Quantity per model / Nombre par modèle														
						alle all tous	019	020	021											
	0730 107 841	S=1,3					1	1	1											
	0730 107 842	S=1,35					1	1	1											
	0730 107 843	S=1,4					1	1	1											
	0730 107 844	S=1,45					1	1	1											
	0730 107 845	S=1,5					1	1	1											
	0730 107 846	S=1,55					1	1	1											
	0730 107 847	S=1,6					1	1	1											
	0730 107 848	S=1,65					1	1	1											
	0730 107 849	S=1,7					1	1	1											
	0730 107 850	S=1,75					1	1	1											
	0730 107 851	S=1,8					1	1	1											
	0730 107 852	S=1,85					1	1	1											
	0730 107 853	S=1,9					1	1	1											
	0730 107 854	S=1,95					1	1	1											
	0730 107 855	S=2,0					1	1	1											
	0730 107 856	S=2,05					1	1	1											
	0730 107 857	S=2,1					1	1	1											
	0730 107 858	S=2,15					1	1	1											
	0730 107 859	S=2,2					1	1	1											
320	0630 502 043 95X3 DIN 472	SICHERUNGSRING	RETAINING RING	JONC D'ARRET			1	1	1											
340	2094 359 037 Z=59	ABTRIEBSWELLE	OUTPUT SHAFT	ARBRE DE SORTIE			1	1	1											
350	0631 610 010 M 10 X 8 DIN 913 8.8	GEWINDESTIFT	SET SCREW	GOUJON FILETE			2	2	2											
370	2094 359 032 Z=60	STIRNRAD	SPUR GEAR	PIGNON CYLINDR.			1	1	1											
380	0630 513 093 SW 65	SPRENGRING	SNAP RING	CIRCLIP			1	1	1											
390	0750 117 267	ROLLENLAGER	ROLLER BEARING	ROULEM.A ROUL.			1	1	1											
400	0735 298 131	NADELLAGER	NEEDLE BEARING	ROULEMT A AIG.			1	1	1											
410	2094 259 020	LAMELLENTRAEGER	DISC CARRIER	PORTE DISQUES			1	1	1											
430	0501 313 598	AUSSENLAMELLE	O.CLUTCH DISC	DISQUE EXT.			10	10	10											

Gruppe 2094 168 SPLITGRUPPE
Group
Groupe

Stückzahl nach Ausführung / Quantity per model /
Nombre par modèle
2094 001 19.05.93

Bild Nr. Fig. No. Fig. No.	Teilnummer Partnumber No. de pièce	Benennung	Description	Désignation	Änderung Modification Modification	alle all tous	Stückzahl nach Ausführung / Quantity per model / Nombre par modèle												
							019	020	021										
440	4642 308 332	INNENLAMELLE	I.CLUTCH DISC	DISQUE INT.			8	8	8										
450		INNENLAMELLE WAHLWEISE	I.CLUTCH DISC OPTIONAL	DISQUE INT. EN OPTION															
	4642 308 332	S=2,0					1	1	1										
	4642 308 330	S=1,5					1	1	1										
	4642 308 331	S=2,5					1	1	1										
470	0501 313 598	AUSSENLAMELLE	O.CLUTCH DISC	DISQUE EXT.			10	10	10										
480	4642 308 332	INNENLAMELLE	I.CLUTCH DISC	DISQUE INT.			8	8	8										
490		INNENLAMELLE WAHLWEISE	I.CLUTCH DISC OPTIONAL	DISQUE INT. EN OPTION															
	4642 308 332	S=2,0					1	1	1										
	4642 308 330	S=1,5					1	1	1										
	4642 308 331	S=2,5					1	1	1										
500	2094 359 033	STIRNRAD	SPUR GEAR	PIGNON CYLINDR.			1	1	1										
510	0634 402 540	R-RING	PISTON RING	SEGMENT			2	2	2										
	35 X 2 DIN 34118	SH P KA																	
520	0750 117 503	ROLLENLAGER	ROLLER BEARING	ROULEM.A ROUL.			1	1	1										
540	2094 359 015	DECKEL	COVER	COUVERCLE			1	1	1										
550	0631 607 118	GEWINDESTIFT	SET SCREW	GOUJON FILETE			2	2	2										
	M 10 X1X 8 DIN 551 5.8																		
570	0634 303 303	O-RING	O-RING	JOINT TORIQUE			1	1	1										
	62 X 4 ZFN 744 NBR -70-10																		
580	0634 303 085	O-RING	O-RING	JOINT TORIQUE			2	2	2										
	12 X 3 ZFN 744 NBR -70-10																		

ZFP-075.00 02/92 30.000

Gruppe 2094 168 SPLITGRUPPE
 Group
 Groupe

Stückzahl nach Ausführung / Quantity per model /
 Nombre par modèle
 2094 001 19.05.93

Bild Nr. Fig. No. Fig. No.	Teilnummer Partnumber No. de pièce	Benennung	Description	Désignation	Änderung Modification Modification	Stückzahl nach Ausführung / Quantity per model / Nombre par modèle														
						alle all tous	019	020	021											
590	0636 015 129 M 10 X 35 DIN 933 8.8	6KT.SCHRAUBE	HEXAGON SCREW	VIS HEXAGONALE			4	4	4											
600		AUSGL.SCHEIBE WAHLWEISE	SHIM OPTIONAL	RONDELLE EN OPTION																
	0730 101 078	S=1,3					1	1	1											
	0730 101 077	S=1,5					1	1	1											
	0730 101 076	S=1,7					1	1	1											
	0730 101 075	S=1,9					1	1	1											
	0730 101 074	S=2,1					1	1	1											
	0730 101 073	S=2,3					1	1	1											
	0730 106 657	S=1,2					1	1	1											
	0730 106 658	S=1,25					1	1	1											
	0730 106 659	S=1,35					1	1	1											
	0730 103 474	S=1,4					1	1	1											
	0730 106 660	S=1,45					1	1	1											
	0730 106 661	S=1,55					1	1	1											
	0730 103 473	S=1,6					1	1	1											
	0730 106 662	S=1,65					1	1	1											
	0730 106 663	S=1,75					1	1	1											
	0730 101 461	S=1,8					1	1	1											
	0730 107 518	S=1,85					1	1	1											
	0730 107 519	S=1,95					1	1	1											
	0730 101 462	S=2,0					1	1	1											
	0730 107 520	S=2,05					1	1	1											
	0730 107 521	S=2,15					1	1	1											
	0730 103 010	S=2,2					1	1	1											
	0730 107 522	S=2,25					1	1	1											

Gruppe 2094 110 ZAPFWELLE
Group P.T.O. SHAFT
Groupe PRISE DE FORCE

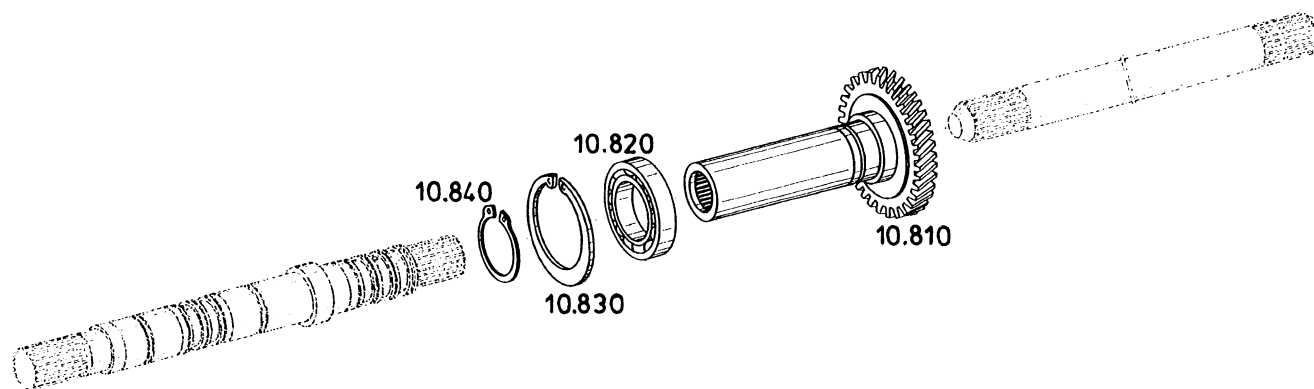

Die Abbildungen sind für die Ausführung nicht verbindlich
Illustrations are not binding for the design
Les illustrations ne sont pas obligatoires pour l'exécution

Gruppe 2094 110 ZAPFWELLE
 Group P.T.O. SHAFT
 Groupe PRISE DE FORCE

Stückzahl nach Ausführung / Quantity per model /
 Nombre par modèle

2094 001

19.05.93

Bild Nr. Fig. No. Fig. No.	Teilnummer Partnumber No. de pièce	Benennung	Description	Désignation	Änderung Modification Modification	Stückzahl nach Ausführung / Quantity per model / Nombre par modèle														
						alle all tous	019	020	021											
810	2094 310 054 Z=46	STIRNRAD	SPUR GEAR	PIGNON CYLINDR.			1	1	1											
820	0635 331 223	KUGELLAGER	BALL BEARING	ROULEM.A BILLES			1	1	1											
830	0630 502 039 80X2,5 DIN 472	SICHERUNGSRING	RETAINING RING	JONC D'ARRET			1	1	1											
840	0630 531 065 50X3 DIN 471	SICHERUNGSRING	RETAINING RING	JONC D'ARRET			1	1	1											

Gruppe 2094 159 LASTSCHALTGR.
 Group
 Groupe

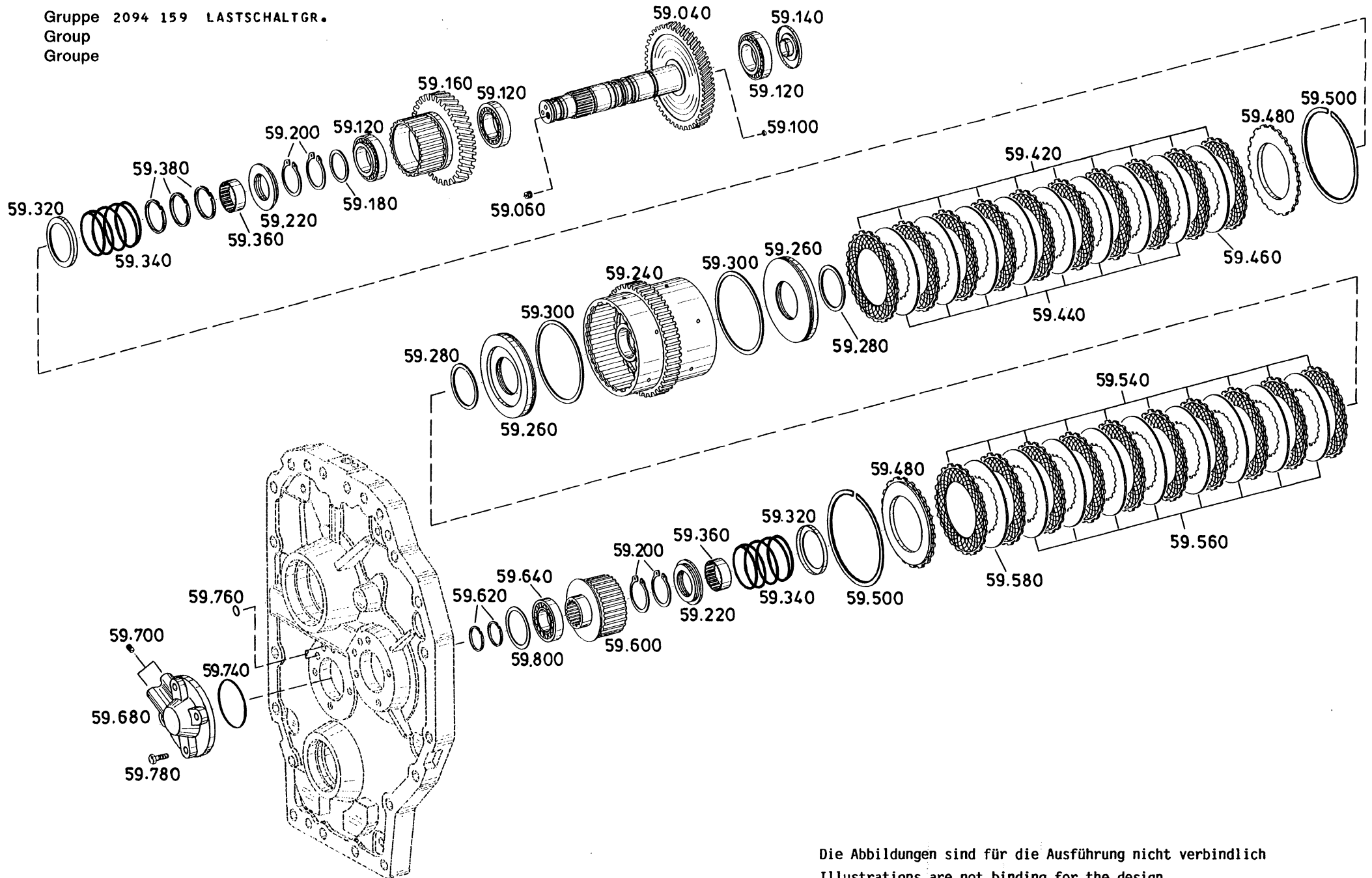

Die Abbildungen sind für die Ausführung nicht verbindlich
 Illustrations are not binding for the design
 Les illustrations ne sont pas obligatoires pour l'exécution

Gruppe 2094 159 LASTSCHALTGR.
 Group
 Groupe

Stückzahl nach Ausführung / Quantity per model /
 Nombre par modèle
 2094 001 19.05.93

Bild Nr. Fig. No. Fig. No.	Teilnummer Partnumber No. de pièce	Benennung	Description	Désignation	Änderung Modification Modification	alle all tous	19.05.93										
							019	020	021								
040	2094 359 038	ZWISCHENWELLE	INTERM.SHAFT	ARBRE INTERM.	36359		1	1	1								
	2094 359 024	ANLAUFTEIL	INTRODUCTION DATE	MOMENT DE DEMARRAGE													
		ZWISCHENWELLE	INTERM.SHAFT	ARBRE INTERM.	36359		1	1	1								
		AUSLAUFTEIL	TERMINATING DATE	MOMENT DE TERMNAISON													
060	0631 610 010	GEWINDESTIFT	SET SCREW	GOUJON FILETE			2	2	2								
	M 10 X 8																
	DIN 913																
	8.8																
100	0730 361 115	VERSCHL.DECKEL	SEALING CAP	COUVERCLE			1	1	1								
120	0750 117 504	ROLLENLAGER	ROLLER BEARING	ROULEM.A ROUL.			3	3	3								
140	2094 359 014	DELFBANGBLECH	OIL COLL.PLATE	TOLE D'HUILE			1	1	1								
160	2094 359 034	STIRNRAD	SPUR GEAR	PIGNON CYLINDR.			1	1	1								
	Z=41																
180		AUSGL.SCHEIBE	SHIM	RONDELLE													
		WAHLWEISE	OPTIONAL	EN OPTION													
	0730 107 826	S=1,0					1	1	1								
	0730 107 827	S=1,3					1	1	1								
	0730 107 828	S=1,35					1	1	1								
	0730 107 829	S=1,4					1	1	1								
	0730 107 830	S=1,45					1	1	1								
	0730 107 831	S=1,5					1	1	1								
	0730 107 832	S=1,55					1	1	1								
	0730 107 833	S=1,6					1	1	1								
	0730 107 834	S=1,65					1	1	1								
	0730 107 835	S=1,7					1	1	1								
	0730 107 836	S=1,75					1	1	1								
	0730 107 837	S=1,8					1	1	1								
200	0630 531 050	SICHERUNGSRING	RETAINING RING	JONC D'ARRET			4	4	4								
	40X2,5																
	DIN 471																
220	0735 298 130	NADELLAGER	NEEDLE BEARING	ROULEMT A AIG.			2	2	2								
240	2094 259 020	LAMELLENTRAEGER	DISC CARRIER	PORTE DISQUES			1	1	1								
260	2094 359 004	KOLBEN	PISTON	PISTON			2	2	2								
280	0750 112 140	PROFILDICHTRING	PROF.SEAL RING	JOINT PROFILE			2	2	2								

Gruppe 2094 159 LASTSCHALTGR.
Group
Groupe

Stückzahl nach Ausführung / Quantity per model /
Nombre par modèle

2094 001

19.05.93

Bild Nr. Fig. No. Fig. No.	Teilnummer Partnumber No. de pièce	Benennung	Description	Désignation	Änderung Modification Modification	Stückzahl nach Ausführung / Quantity per model / Nombre par modèle														
						alle all tous	019	020	021											
300	0734 307 183	PROFILDICHTRING	PROF. SEAL RING	JOINT PROFILE			2	2	2											
320	4642 308 083	FUEHRUNGSRING	GUIDE RING	BAGUE GUIDAGE			2	2	2											
340	0732 041 183	DRUCKFEDER	COMPR. SPRING	RESSORT PRESS.			2	2	2											
360	0750 115 365	NADELHUELSE	NEEDLE SLEEVE	DOUILLE A AIG.			2	2	2											
380	0634 402 541 40 X 2 DIN 34118	R-RING SH P KA	PISTON RING	SEGMENT			3	3	3											
420	0501 313 598	AUSSENLAMELLE	O. CLUTCH DISC	DISQUE EXT.			10	10	10											
440	4642 308 332	INNENLAMELLE	I. CLUTCH DISC	DISQUE INT.			8	8	8											
460		INNENLAMELLE WAHLWEISE	I. CLUTCH DISC OPTIONAL	DISQUE INT. EN OPTION																
	4642 308 332	S=2,0					1	1	1											
	4642 308 330	S=1,5					1	1	1											
	4642 308 331	S=2,5					1	1	1											
480	4642 308 185	ENDSCHEIBE	END SHIM	RONDELLE			2	2	2											
500	0730 513 180	SPRENGRING	SNAP RING	CIRCLIP			2	2	2											
540	0501 313 598	AUSSENLAMELLE	O. CLUTCH DISC	DISQUE EXT.			10	10	10											
560	4642 308 332	INNENLAMELLE	I. CLUTCH DISC	DISQUE INT.			8	8	8											
580		INNENLAMELLE WAHLWEISE	I. CLUTCH DISC OPTIONAL	DISQUE INT. EN OPTION																
	4642 308 332	S=2,0					1	1	1											
	4642 308 330	S=1,5					1	1	1											
	4642 308 331	S=2,5					1	1	1											
600	2094 359 011	INNENL. TRAEGER	I. DISC CARRIER	PORTE-DISQ. INT.			1	1	1											
620	0634 402 540 35 X 2 DIN 34118	R-RING SH P KA	PISTON RING	SEGMENT			2	2	2											
640	0750 117 503	ROLLENLAGER	ROLLER BEARING	ROULEM. A ROUL.			1	1	1											

Gruppe 2094 159 LASTSCHALTGR.
 Group
 Groupe

Stückzahl nach Ausführung / Quantity per model /
 Nombre par modèle

2094 001

19.05.93

Bild Nr. Fig. No. Fig. No.	Teilnummer Partnumber No. de pièce	Benennung	Description	Désignation	Änderung Modification Modification	Stückzahl nach Ausführung / Quantity per model / Nombre par modèle														
						alle all tous	019	020	021											
680	2094 359 015	DECKEL	COVER	COUVERCLE			1	1	1											
700	0631 607 118 M 10 X1X 8 DIN 551 5.8	GEWINDESTIFT	SET SCREW	GOUJON FILETE			2	2	2											
740	0634 303 303 62 X 4 ZFN 744 NBR -70-10	O-RING	O-RING	JOINT TORIQUE			1	1	1											
760	0634 303 085 12 X 3 ZFN 744 NBR -70-10	O-RING	O-RING	JOINT TORIQUE			2	2	2											
780	0636 015 129 M 10 X 35 DIN 933 8.8	6KT.SCHRAUBE	HEXAGON SCREW	VIS HEXAGONALE			4	4	4											
800		AUSGL.SCHEIBE WAHLWEISE	SHIM OPTIONAL	RONDELLE EN OPTION																
	0730 101 078	S=1,3					1	1	1											
	0730 101 077	S=1,5					1	1	1											
	0730 101 076	S=1,7					1	1	1											
	0730 101 075	S=1,9					1	1	1											
	0730 101 074	S=2,1					1	1	1											
	0730 101 073	S=2,3					1	1	1											
	0730 106 657	S=1,2					1	1	1											
	0730 106 658	S=1,25					1	1	1											
	0730 106 659	S=1,35					1	1	1											
	0730 103 474	S=1,4					1	1	1											
	0730 106 660	S=1,45					1	1	1											
	0730 106 661	S=1,55					1	1	1											
	0730 103 473	S=1,6					1	1	1											
	0730 106 662	S=1,65					1	1	1											
	0730 106 663	S=1,75					1	1	1											
	0730 101 461	S=1,8					1	1	1											
	0730 107 518	S=1,85					1	1	1											
	0730 107 519	S=1,95					1	1	1											
	0730 101 462	S=2,0					1	1	1											
	0730 107 520	S=2,05					1	1	1											

Gruppe 2094 159 LASTSCHALTGR.
 Group
 Groupe

Stückzahl nach Ausführung / Quantity per model /
 Nombre par modèle

2094 001

19.05.93

Bild Nr. Fig. No. Fig. No.	Teilnummer Partnumber No. de pièce	Benennung	Description	Désignation	Änderung Modification Modification	alle all tous	Stückzahl nach Ausführung / Quantity per model / Nombre par modèle												
							019	020	021										
	0730 107 521	S=2,15					1	1	1										
	0730 103 010	S=2,2					1	1	1										
	0730 107 522	S=2,25					1	1	1										

ZFP-075.00 02/92 30.000

Gruppe 2094 101 GETR.GEHAEUSE
 Group GEARBOX HOUSING
 Groupe CARTER DE BOITE

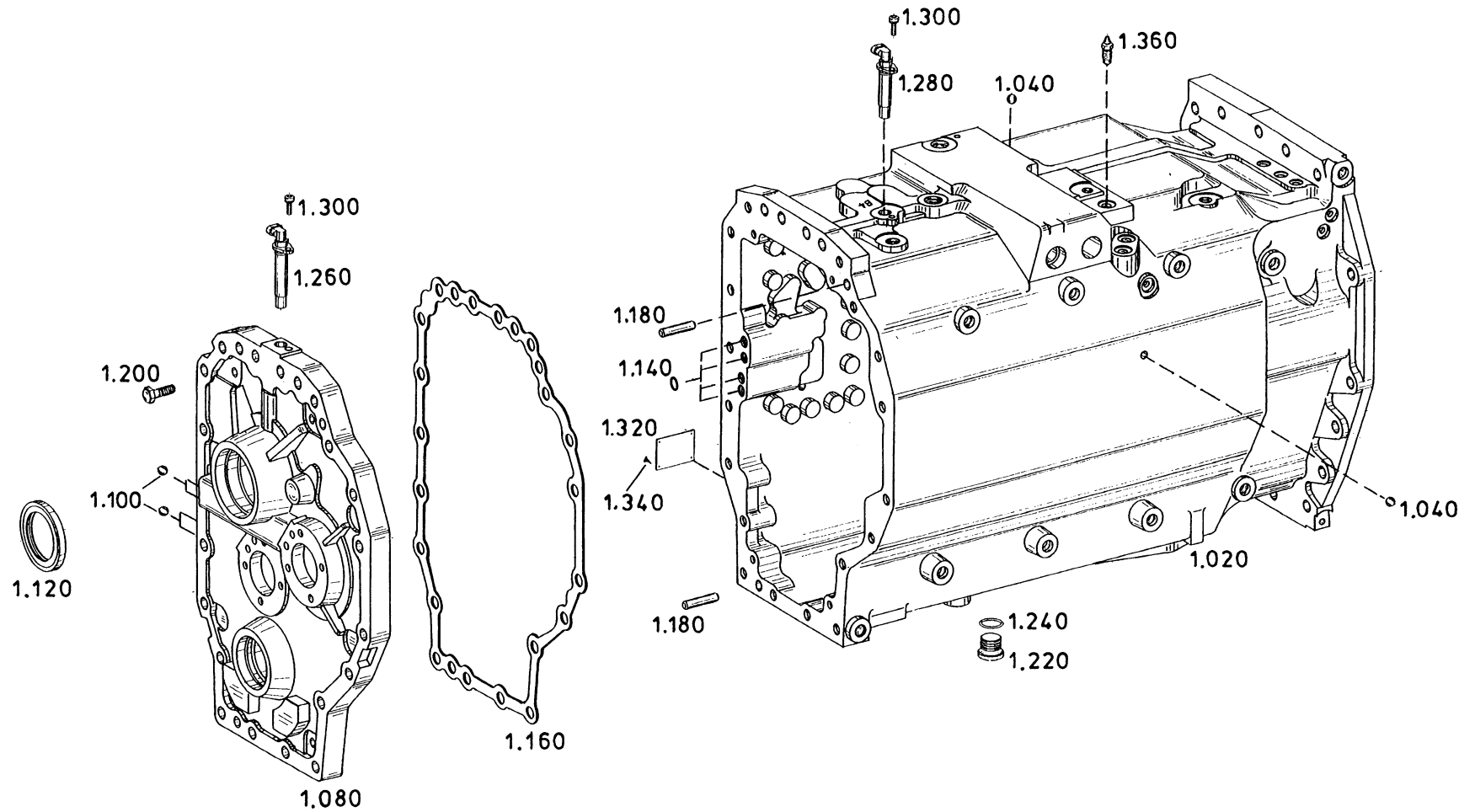

Die Abbildungen sind für die Ausführung nicht verbindlich
 Illustrations are not binding for the design
 Les illustrations ne sont pas obligatoires pour l'exécution

Gruppe 2094 101 GETR.GEHAUSE
 Group GEARBOX HOUSING
 Groupe CARTER DE BOITE

Stückzahl nach Ausführung / Quantity per model /
 Nombre par modèle

2094 001

19.05.93

Bild Nr. Fig. No. Fig. No.	Teilnummer Partnumber No. de pièce	Benennung	Description	Désignation	Änderung Modification Modification	Stückzahl nach Ausführung / Quantity per model / Nombre par modèle														
						alle all tous	019	020	021											
020	2094 301 024	GEHAUSE	HOUSING	CARTER			1	1	1											
040	0635 460 022	KUGEL	BALL	BILLE			3	3	3											
080	2094 301 026	DECKEL	COVER	COUVERCLE			1	1	1											
100	0635 460 021	KUGEL	BALL	BILLE			4	4	4											
120	0734 319 427	WELLENDICHTRING	SHAFT SEAL	BAGUE ETANCH.			1	1	1											
140	0634 303 085 12 X 3 ZFN 744 NBR -70-10	O-RING	O-RING	JOINT TORIQUE			4	4	4											
160	2094 301 027	DICHTUNG	GASKET	JOINT			1	1	1											
180	0631 306 670 16 M 6X 70 ZFN 6 ST50K * 9S20K	ZYLINDERSTIFT	CYLINDRICAL PIN	GOUPILLE CYL.			2	2	2											
200	0636 011 356 M 12 X 45 DIN 931 10.9	6KT.SCHRAUBE	HEXAGON SCREW	VIS HEXAGONALE			4	4	4											
220	0636 302 009 M 33X2 DIN 908 ST	VERSCHL.SCHR.	SCREW PLUG	VIS FERMETURE			1	1	1											
240	0634 303 312 30 X 2,5 ZFN 744 NBR -70-10	O-RING	O-RING	JOINT TORIQUE			1	1	1											
260	0501 209 013	SENSOR					1	1	1											
280	0501 208 802	SENSOR					1	1	1											

Gruppe 2094 101 GETR.GEHAEUSE
 Group GEARBOX HOUSING
 Groupe CARTER DE BOITE

Stückzahl nach Ausführung / Quantity per model /
 Nombre par modèle
 2094 001 19.05.93

Bild Nr. Fig. No. Fig. No.	Teilnummer Partnumber No. de pièce	Benennung	Description	Désignation	Änderung Modification Modification	Stückzahl nach Ausführung / Quantity per model / Nombre par modèle														
						alle all tous	019	020	021											
300	0636 101 027 M 8 X 20 DIN 912 8.8	ZYL.SCHRAUBE	CAP SCREW	VIS TETE CYL.			2	2	2											
320	0730 365 124	BAUMUSTERSCHILD	TYPE PLATE	PLAQUE SIGNALET			1	1	1											
340	0631 311 009 3 X 5 DIN 1476 ST	KERBNAGEL	GROOVED STUD	RIVET CANNELE			4	4	4											
360	0637 885 219 MR 0080 M14X1,5	ENTLUEFTER	BREATHER	RENIFLARD			2	2	2											

Gruppe 2094 113 FAHRKUPPLUNG
 Group DRIVE CLUTCH
 Groupe EMBRAYAGE

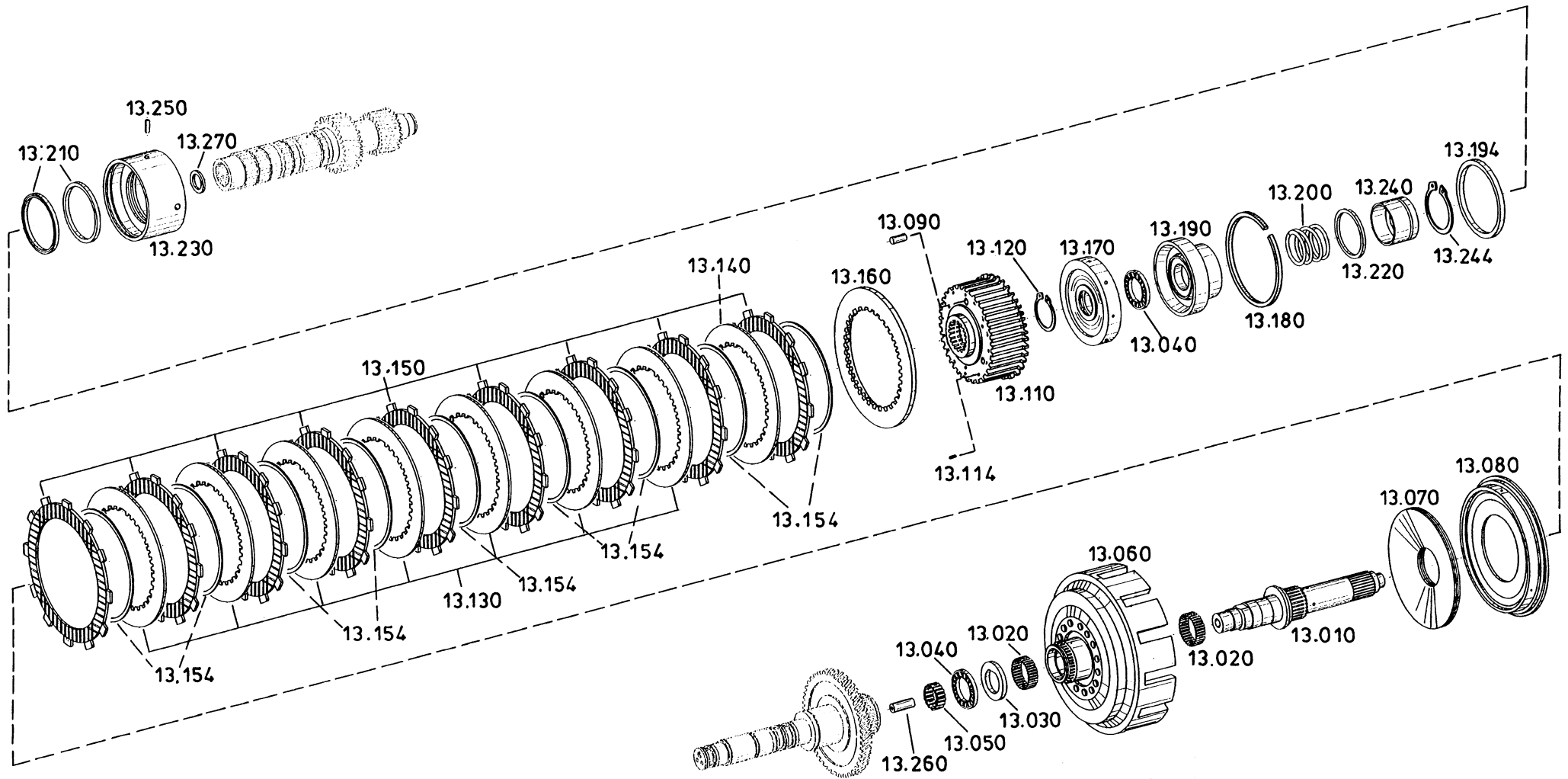

Die Abbildungen sind für die Ausführung nicht verbindlich
 Illustrations are not binding for the design
 Les illustrations ne sont pas obligatoires pour l'exécution

Gruppe 2094 113 FAHRKUPPLUNG
 Group DRIVE CLUTCH
 Groupe EMBRAYAGE

Stückzahl nach Ausführung / Quantity per model /
 Nombre par modèle

2094 001

19.05.93

Bild Nr. Fig. No. Fig. No.	Teilnummer Partnumber No. de pièce	Benennung	Description	Désignation	Änderung Modification Modification	Stückzahl nach Ausführung / Quantity per model / Nombre par modèle														
						alle all tous	019	020	021											
010	2094 313 062	KUPPLUNGSWELLE	CLUTCH SHAFT	ARBRE D'EMBR.			1	1	1											
020	0750 115 360	NADELKRANZ	NEEDLE CAGE	CAGE A AIG.			2	2	2											
030		SCHEIBE WAHLWEISE	WASHER OPTIONAL	RONDELLE EN OPTION																
	0730 108 656	A=6,0					1	1	1											
	0730 108 657	A=6,1					1	1	1											
	0730 108 658	A=6,2					1	1	1											
	0730 108 659	A=6,3					1	1	1											
	0730 108 660	A=6,4					1	1	1											
	0730 108 661	A=6,5					1	1	1											
	0730 108 662	A=6,6					1	1	1											
	0730 108 663	A=6,7					1	1	1											
	0730 108 664	A=6,8					1	1	1											
	0730 108 665	A=6,9					1	1	1											
	0730 108 666	A=7,0					1	1	1											
	0730 108 667	A=7,1					1	1	1											
	0730 108 668	A=7,2					1	1	1											
	0730 108 669	A=7,3					1	1	1											
	0730 108 670	A=7,4					1	1	1											
040	0750 115 358	AX.ROLLENLAGER	AX.ROLLER BEAR.	BUTEE AX.ROULX.			2	2	2											
050	0750 115 357	NADELKRANZ	NEEDLE CAGE	CAGE A AIG.			1	1	1											
060	2094 213 010	KUPPLGS.GLOCKE					1	1	1											
070	0501 313 704	TELLERFEDER	CUP SPRING	RONDELLE BELLEV			1	1	1											
080	2094 313 048	DRUCKPLATTE	PRESSURE PLATE	PLAQUE PRESSION			1	1	1											
090	2094 313 055	DRUCKBOLZEN	PRESSURE PIN	BOULON PRESSION			3	3	3											
110	2094 313 061	INNENL.TRAEGER	I.DISC CARRIER	PORTE-DISQ.INT.			1	1	1											
114	1043 333 128	VERSCHL.DECKEL	SEALING CAP	COUVERCLE			14	14	14											
120	0630 531 065	SICHERUNGSRING	RETAINING RING	JONC D'ARRET			1	1	1											
	50X3 DIN 471																			
130	2094 313 060	INNENLAMELLE	I.CLUTCH DISC	DISQUE INT.			7	7	7											

Gruppe 2094 113 FAHRKUPPLUNG
 Group DRIVE CLUTCH
 Groupe EMBRAYAGE

Stückzahl nach Ausführung / Quantity per model /
 Nombre par modèle

2094 001

19.05.93

Bild Nr. Fig. No. Fig. No.	Teilnummer Partnumber No. de pièce	Benennung	Description	Désignation	Änderung Modification Modification	Stückzahl nach Ausführung / Quantity per model / Nombre par modèle														
						alle all tous	019	020	021											
140		INNENLAMELLE WAHLWEISE	I.CLUTCH DISC OPTIONAL	DISQUE INT. EN OPTION																
	2094 313 052	A=2,9					1	1	1											
	2094 313 053	A=3,2					1	1	1											
	2094 313 054	A=3,5					1	1	1											
150	2094 213 009	BELAGLAMELLE	LIN.CLUTCH DISC	DISQUE GARNIT.			9	9	9											
154	0501 313 607	FEDER	SPRING	RESSORT			9	9	9											
160		ENDSCHEIBE WAHLWEISE	END SHIM OPTIONAL	RONDELLE EN OPTION																
	2094 313 046	A=4,9					1	1	1											
	2094 313 047	A=5,7					1	1	1											
170	2094 313 049	DRUCKRING	PRESSURE RING	CONE SERRAGE			1	1	1											
180	0630 513 137 SB 137	SPRENGRING	SNAP RING	CIRCLIP			1	1	1											
190	2094 313 050	KOLBEN	PISTON	PISTON			1	1	1											
194	0501 313 668	DICHTRING	SEALING RING	BAGUE ETANCH.			1	1	1											
200	0732 042 353	DRUCKFEDER	COMPR.SPRING	RESSORT PRESS.			1	1	1											
210	0501 312 243	DICHTRING	SEALING RING	BAGUE ETANCH.			2	2	2											
220	0501 312 244	DICHTRING	SEALING RING	BAGUE ETANCH.			1	1	1											
230	2094 313 051	BUCHSE	BUSH	DOUILLE			1	1	1											
240	2094 313 056	BUCHSE	BUSH	DOUILLE			1	1	1											
244	0630 531 288 67X2,5 A67	SICHERUNGSRING	RETAINING RING	JONC D'ARRET			1	1	1											
250	0631 329 078 8 X 18 DIN 1481	SPANNSTIFT	SLOT.PIN	GOUPILLE ELAST.			1	1	1											
260	2094 313 059	ROHR	PIPE	TUBE			1	1	1											
270		SCHEIBE WAHLWEISE	WASHER OPTIONAL	RONDELLE EN OPTION																

Gruppe 2094 113 FAHRKUPPLUNG
 Group DRIVE CLUTCH
 Groupe EMBRAYAGE

Stückzahl nach Ausführung / Quantity per model /
 Nombre par modèle
 2094 001 19.05.93

Bild Nr. Fig. No. Fig. No.	Teilnummer Partnumber No. de pièce	Benennung	Description	Désignation	Anderung Modification Modification	alle all tous	Stückzahl nach Ausführung / Quantity per model / Nombre par modèle												
							019	020	021										
	0730 108 562	S=3,0					1	1	1										
	0730 108 561	S=2,9					1	1	1										
	0730 108 560	S=2,8					1	1	1										
	0730 108 559	S=2,7					1	1	1										
	0730 108 558	S=2,6					1	1	1										
	0730 108 557	S=2,5					1	1	1										
	0730 108 556	S=2,4					1	1	1										
	0730 108 555	S=2,3					1	1	1										
	0730 108 554	S=2,2					1	1	1										
	0730 108 553	S=2,1					1	1	1										
	0730 108 552	S=2,0					1	1	1										
	0730 108 551	S=1,9					1	1	1										
	0730 108 550	S=1,8					1	1	1										
	0730 108 549	S=1,7					1	1	1										
	0730 108 548	S=1,6					1	1	1										
	0730 108 547	S=1,5					1	1	1										

Gruppe 2094 114 KRIECHGANG
Group CRAWLER
Groupe VIT-EXTRA-LENTE

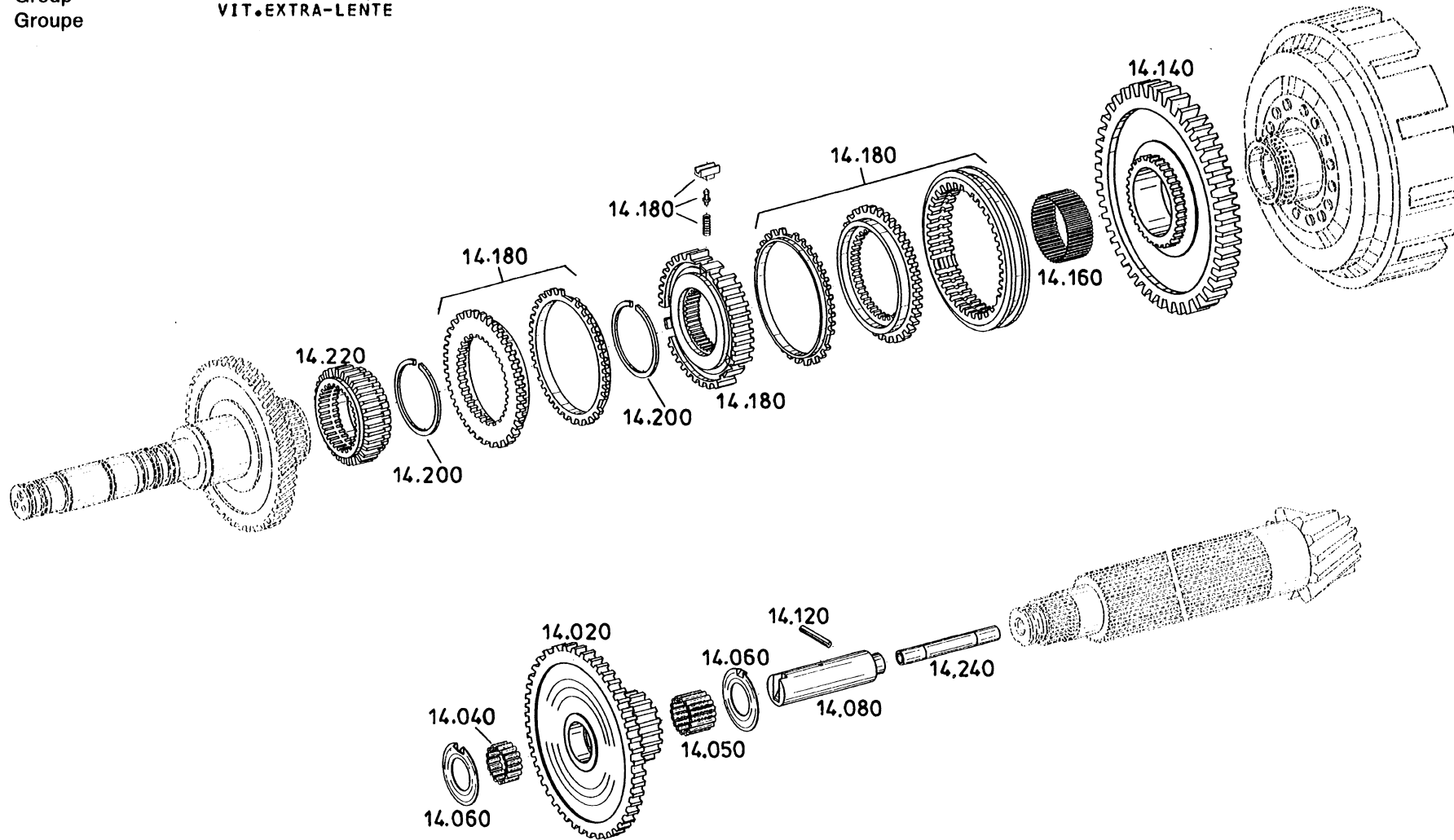

Die Abbildungen sind für die Ausführung nicht verbindlich
Illustrations are not binding for the design
Les illustrations ne sont pas obligatoires pour l'exécution

Gruppe 2094 114 KRIECHGANG
 Group CRAWLER
 Groupe VIT.EXTRA-LENTE

Stückzahl nach Ausführung / Quantity per model /
 Nombre par modèle
 2094 001 19.05.93

Bild Nr. Fig. No. Fig. No.	Teilnummer Partnumber No. de pièce	Benennung	Description	Désignation	Änderung Modification Modification	Stückzahl nach Ausführung / Quantity per model / Nombre par modèle														
						alle all tous	019	020	021											
020	2094 314 020 Z=69	DOPPELRAD	DOUBLE GEAR	PIGNON DOUBLE			1	1	1											
040	0750 115 357	NADELKRANZ	NEEDLE CAGE	CAGE A AIG.			1	1	1											
050	0735 320 114	NADELKAEFIG	NEEDLE CAGE	CAGE A AIG.			1	1	1											
060	0730 102 047	ANLAUFSCHLEIBE	THRUST WASHER	RONDELLE BUTEE			2	2	2											
080	2094 314 013	BOLZEN	PIN	AXE			1	1	1											
120	0631 329 072 6 X 40 DIN 1481	SPANNSTIFT	SLOT.PIN	GOUPILLE ELAST.			1	1	1											
140	2094 314 019 Z=60	ZAHNRAD	GEAR	PIGNON			1	1	1											
160	0750 115 359	NADELKRANZ	NEEDLE CAGE	CAGE A AIG.			1	1	1											
180	6002 000 894	SYNCHRONISIERG.	SYNCHRONIZER	SYNCHRONISATION			1	1	1											
200	0630 513 123 SW 63	SPRENGRING	SNAP RING	CIRCLIP			2	2	2											
220	2094 314 015 Z=32	ZAHNRAD	GEAR	PIGNON			1	1	1											
240	2094 314 007	ROHR	PIPE	TUBE			1	1	1											

Gruppe 2094 103 VORGELEGEWELLE
 Group LAYSHAFT
 Groupe ARBRE INTERM.

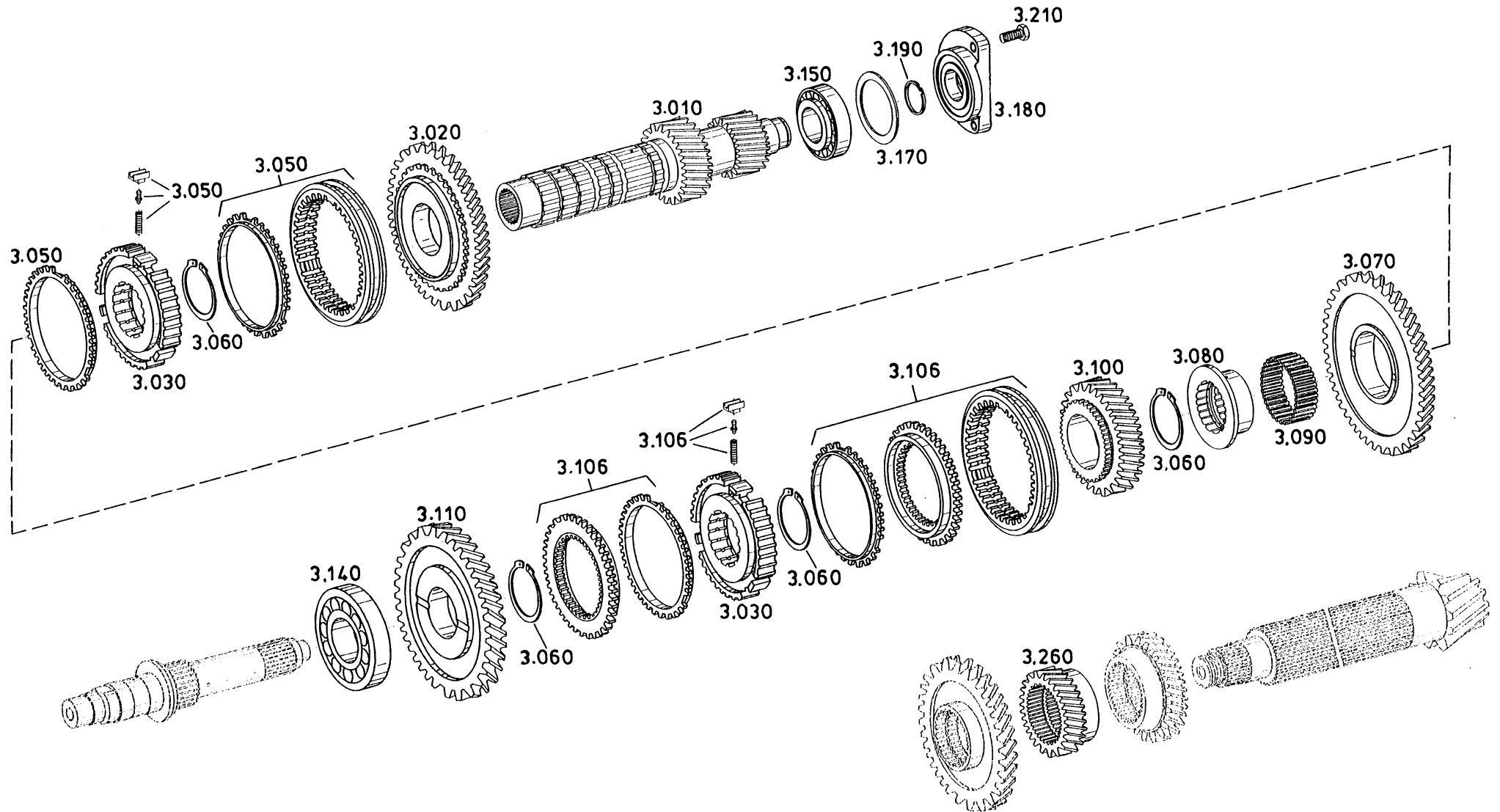

Die Abbildungen sind für die Ausführung nicht verbindlich
 Illustrations are not binding for the design
 Les illustrations ne sont pas obligatoires pour l'exécution

Gruppe 2094 103 VORGELEGEWELLE
 Group LAYSCHAFT
 Groupe ARBRE INTERM.

Stückzahl nach Ausführung / Quantity per model /
 Nombre par modèle

2094 001

19.05.93

Bild Nr. Fig. No. Fig. No.	Teilnummer Partnumber No. de pièce	Benennung	Description	Désignation	Änderung Modification Modification	Stückzahl nach Ausführung / Quantity per model / Nombre par modèle														
						alle all tous	019	020	021											
010	2094 303 018 Z=18/22	VORGELEGEWELLE	LAYSCHAFT	ARBRE INTERM.			1	1	1											
020	2094 303 020 Z=47/5.G	ZAHNRAD	GEAR	PIGNON			1	1	1											
030	6002 305 554 ZF-B114	SYNCHRONKÖRPER	SYNCHRO.BODY	MOYEU SYNCHRON.			2	2	2											
050	6002 199 015	SYNCHRONTEILE					1	1	1											
060	0730 501 442	SICHERUNGSRING	RETAINING RING	JONC D'ARRET			4	4	4											
070	2094 303 023 Z=58/6.G	ZAHNRAD	GEAR	PIGNON			1	1	1											
080		BUCHSE WAHLWEISE	BUSH OPTIONAL	DOUILLE EN OPTION																
	2094 303 028						1	1	1											
	2094 303 029						1	1	1											
	2094 303 030						1	1	1											
090	0750 115 081	NADELKAEFIG	NEEDLE CAGE	CAGE A AIG.			1	1	1											
100	2094 303 025 Z=25/3.G	ZAHNRAD	GEAR	PIGNON			1	1	1											
106	6002 199 016	SYNCHRONTEILE					1	1	1											
110	2094 303 026 Z=35/4.G	ZAHNRAD	GEAR	PIGNON			1	1	1											
140	0750 117 588	ROLLENLAGER	ROLLER BEARING	ROULEM.A ROUL.			1	1	1											
150	0750 117 618	ROLLENLAGER	ROLLER BEARING	ROULEM.A ROUL.			1	1	1											
170		AUSGL.SCHEIBE WAHLWEISE	SHIM OPTIONAL	RONDELLE EN OPTION																
	1232 304 085 S=2,6						1	1	1											
	1232 304 084 S=2,55						1	1	1											
	1232 304 083 S=2,5						1	1	1											
	1232 304 082 S=2,45						1	1	1											
	1232 304 061 S=2,4						1	1	1											
	1232 304 081 S=2,35						1	1	1											
	1232 304 080 S=2,3						1	1	1											
	1232 304 079 S=2,25						1	1	1											
	1232 304 078 S=2,2						1	1	1											
	1232 304 077 S=2,15						1	1	1											
	1232 304 032 S=2,1						1	1	1											
	1232 304 076 S=2,05						1	1	1											

ZFP-075.00 02/92 30.000

Gruppe 2094 103 VORGELEGEWELLE
 Group LAYSCHAFT
 Groupe ARBRE INTERM.

Stückzahl nach Ausführung / Quantity per model /
 Nombre par modèle

2094 001

19.05.93

Bild Nr. Fig. No. Fig. No.	Teilnummer Partnumber No. de pièce	Benennung	Description	Désignation	Änderung Modification Modification	Stückzahl nach Ausführung / Quantity per model / Nombre par modèle														
						alle all tous	019	020	021											
	1232 304 075	S=2,0					1	1	1											
	1232 304 074	S=1,95					1	1	1											
	1232 304 033	S=1,9					1	1	1											
	1232 304 073	S=1,85					1	1	1											
	1232 304 059	S=1,8					1	1	1											
	1232 304 058	S=1,75					1	1	1											
	1232 304 049	S=1,7					1	1	1											
	1232 304 057	S=1,65					1	1	1											
	1232 304 056	S=1,6					1	1	1											
180	2094 303 006	DECKEL	COVER	COUVERCLE			1	1	1											
190	0634 402 540 35 X 2 DIN 34118	R-RING SH P KA	PISTON RING	SEGMENT			1	1	1											
210	0636 015 124 M 10 X 28 DIN 933 8.8	6KT.SCHRAUBE	HEXAGON SCREW	VIS HEXAGONALE			3	3	3											
260	2094 304 029 Z=27/6.6	ZAHNRAD	GEAR	PIGNON			1	1	1											

Gruppe 2094 104 HAUPTWELLE
 Group MAIN SHAFT
 Groupe ARBRE PRINCIPAL

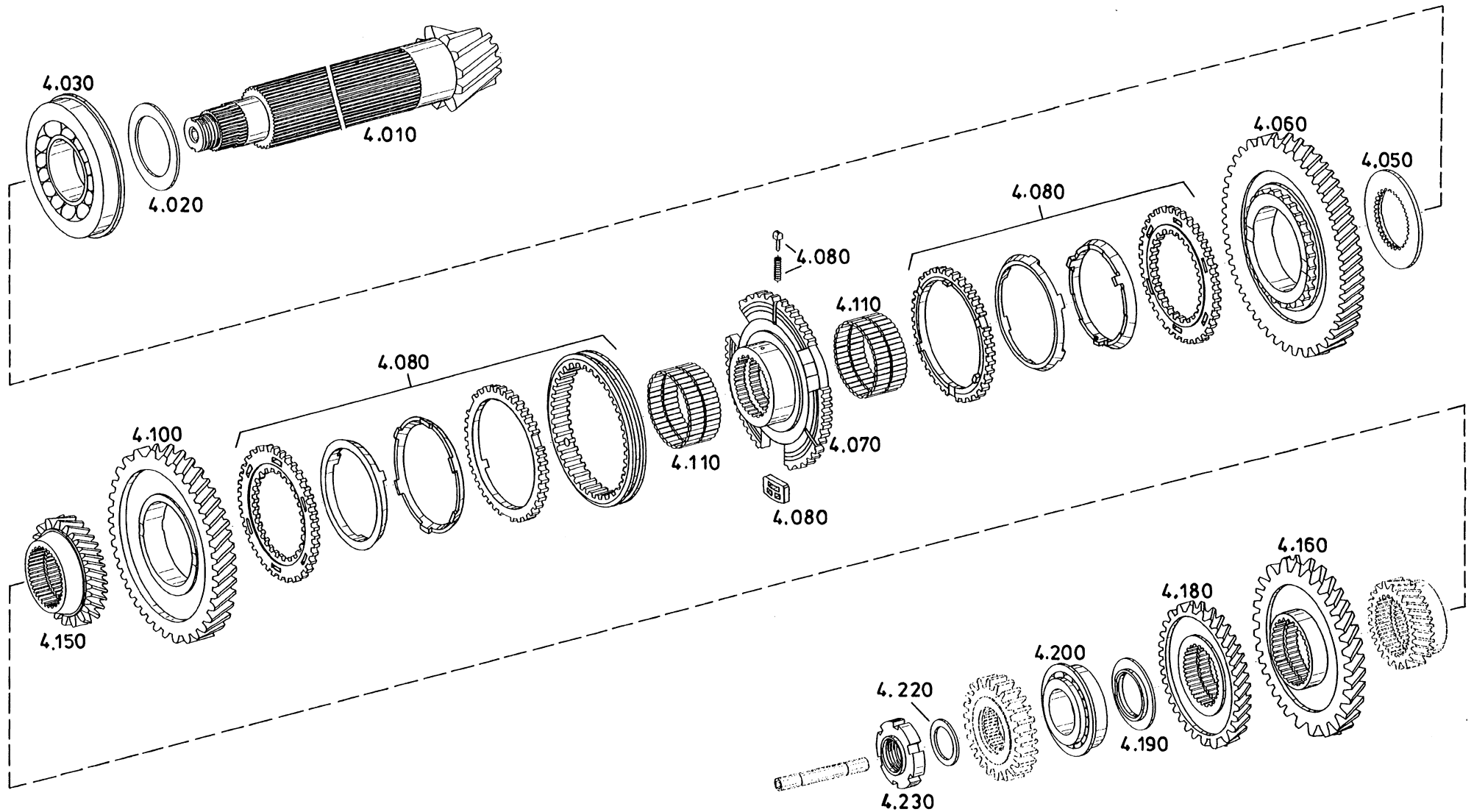

Die Abbildungen sind für die Ausführung nicht verbindlich
 Illustrations are not binding for the design
 Les illustrations ne sont pas obligatoires pour l'exécution

Gruppe 2094 104 HAUPTWELLE
 Group MAIN SHAFT
 Groupe ARBRE PRINCIPAL

Stückzahl nach Ausführung / Quantity per model /
 Nombre par modèle

2094 001

19.05.93

Bild Nr. Fig. No. Fig. No.	Teilnummer Partnumber No. de pièce	Benennung	Description	Désignation	Änderung Modification Modification	Stückzahl nach Ausführung / Quantity per model / Nombre par modèle														
						alle all tous	019	020	021											
010	2094 304 051 Z=10 LI	HAUPTWELLE	MAIN SHAFT	ARBRE PRINCIPAL			1	1	1											
020		SCHEIBE WAHLWEISE	WASHER OPTIONAL	RONDELLE EN OPTION																
	0730 107 723	S=3,4					1	1	1											
	0730 107 722	S=3,35					1	1	1											
	0730 107 721	S=3,3					1	1	1											
	0730 107 720	S=3,25					1	1	1											
	0730 107 719	S=3,20					1	1	1											
	0730 107 718	S=3,15					1	1	1											
	0730 107 717	S=3,1					1	1	1											
	0730 107 724	S=3,05					1	1	1											
	0730 107 716	S=3,0					1	1	1											
	0730 108 426	S=3,45					1	1	1											
	0730 108 427	S=3,50					1	1	1											
	0730 108 428	S=3,55					1	1	1											
	0730 108 429	S=3,60					1	1	1											
030	0750 117 499	ROLLENLAGER	ROLLER BEARING	ROULEM.A ROUL.			1	1	1											
050	2094 304 038	ANLAUFSSCHEIBE	THRUST WASHER	RONDELLE BUTEE			1	1	1											
060	2094 304 039	ZAHNRAD	GEAR	PIGNON			1	1	1											
070	6002 305 972	SYNCHRONKOERPER ANLAUFTEIL	SYNCHRO.BODY INTRODUCTION DATE	MOYEU SYNCHRON. MOMENT DE DEMARRAGE	37964		1	1	1											
	6002 305 858	SYNCHRONKOERPER AUSLAUFTEIL	SYNCHRO.BODY TERMINATING DATE	MOYEU SYNCHRON. MOMENT DE TERMNAISON	37964		1	1	1											
080	6002 199 018	SYNCHRONTEILE ANLAUFTEIL	INTRODUCTION DATE	MOMENT DE DEMARRAGE	37964		1	1	1											
	6002 199 009	SYNCHRONTEILE AUSLAUFTEIL	TERMINATING DATE	MOMENT DE TERMNAISON	37964		1	1	1											
100	2094 304 040	ZAHNRAD	GEAR	PIGNON			1	1	1											
110	0735 321 219	NADELKRANZ	NEEDLE CAGE	CAGE A AIG.			2	2	2											
150	2094 304 042	ZAHNRAD	GEAR	PIGNON			1	1	1											
160	2094 304 043	ZAHNRAD	GEAR	PIGNON			1	1	1											
180	2094 304 044	ZAHNRAD	GEAR	PIGNON			1	1	1											
190		AUSGL.SCHEIBE WAHLWEISE	SHIM OPTIONAL	RONDELLE EN OPTION																

Gruppe 2094 104 HAUPTWELLE
 Group MAIN SHAFT
 Groupe ARBRE PRINCIPAL

Stückzahl nach Ausführung / Quantity per model /
 Nombre par modèle

2094 001

19.05.93

Bild Nr. Fig. No. Fig. No.	Teilnummer Partnumber No. de pièce	Benennung	Description	Désignation	Änderung Modification Modification	Stückzahl nach Ausführung / Quantity per model / Nombre par modèle														
						alle all tous	019	020	021											
	0730 108 067	S=9,00					1	1	1											
	0730 108 068	S=8,90					1	1	1											
	0730 108 074	S=8,80					1	1	1											
	0730 108 069	S=8,70					1	1	1											
	0730 108 070	S=8,60					1	1	1											
	0730 108 076	S=8,50					1	1	1											
	0730 108 071	S=8,40					1	1	1											
	0730 108 072	S=8,30					1	1	1											
	0730 108 073	S=8,20					1	1	1											
	0730 108 075	S=8,10					1	1	1											
	0730 108 077	S=8,00					1	1	1											
	0730 108 079	S=7,90					1	1	1											
	0730 108 081	S=7,80					1	1	1											
	0730 108 083	S=7,70					1	1	1											
	0730 108 078	S=7,60					1	1	1											
	0730 108 084	S=7,50					1	1	1											
	0730 108 085	S=7,40					1	1	1											
	0730 108 080	S=7,30					1	1	1											
	0730 108 086	S=7,20					1	1	1											
	0730 108 087	S=7,10					1	1	1											
200	0750 117 498	ROLLENLAGER	ROLLER BEARING	ROULEM.A ROUL.			1	1	1											
220		SCHEIBE WAHLWEISE	WASHER OPTIONAL	RONDELLE EN OPTION																
	0730 107 714	S=3,5					1	1	1											
	0730 107 713	S=3,4					1	1	1											
	0730 107 712	S=3,3					1	1	1											
	0730 107 711	S=3,2					1	1	1											
	0730 107 710	S=3,1					1	1	1											
	0730 107 709	S=3,0					1	1	1											
	0730 107 708	S=2,9					1	1	1											
	0730 107 707	S=2,8					1	1	1											
	0730 107 706	S=2,7					1	1	1											
	0730 107 705	S=2,6					1	1	1											
	0730 107 704	S=2,5					1	1	1											
	0730 107 703	S=2,4					1	1	1											
	0730 107 702	S=2,3					1	1	1											
	0730 107 701	S=2,2					1	1	1											
	0730 107 700	S=2,1					1	1	1											
	0730 107 699	S=2,0					1	1	1											
	0730 107 698	S=1,9					1	1	1											
	0730 107 697	S=1,8					1	1	1											
	0730 107 696	S=1,75					1	1	1											

Gruppe 2094 104 HAUPTWELLE
 Group MAIN SHAFT
 Groupe ARBRE PRINCIPAL

Stückzahl nach Ausführung / Quantity per model /
 Nombre par modèle

2094 001

19.05.93

Bild Nr. Fig. No. Fig. No.	Teilnummer Partnumber No. de pièce	Benennung	Description	Désignation	Anderung Modification Modification	alle all tous	Stückzahl nach Ausführung / Quantity per model / Nombre par modèle												
							019	020	021										
	0730 107 695	S=1,7					1	1	1										
	0730 107 694	S=1,65					1	1	1										
	0730 107 693	S=1,6					1	1	1										
	0730 107 692	S=1,55					1	1	1										
	0730 107 691	S=1,5					1	1	1										
	0730 107 690	S=1,45					1	1	1										
	0730 107 689	S=1,4					1	1	1										
	0730 107 688	S=1,35					1	1	1										
	0730 107 687	S=1,3					1	1	1										
	0730 107 686	S=1,25					1	1	1										
	0730 107 685	S=1,2					1	1	1										
230	0737 502 164	NUTMUTTER	SLOTTED NUT	ECROU CANNELE			1	1	1										

ZFP-075.00 02/92 30.000

Gruppe 2094 146 VORDERRADANTR.
 Group FRONT WH.DRIVE
 Groupe ENTRAIN.ROUE AV

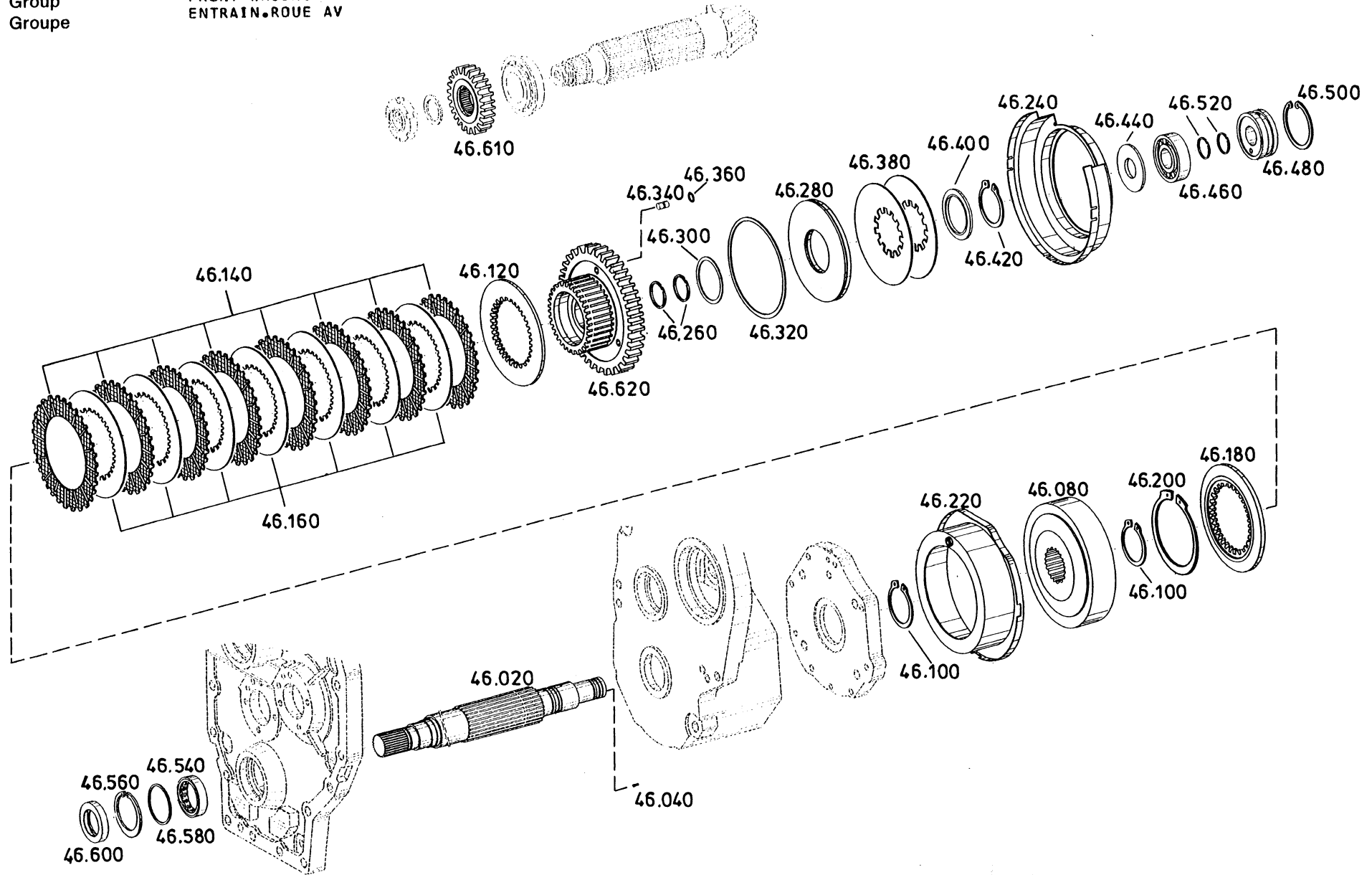

Die Abbildungen sind für die Ausführung nicht verbindlich
 Illustrations are not binding for the design
 Les illustrations ne sont pas obligatoires pour l'exécution

Gruppe 2094 146 VORDERRADANTR.
 Group FRONT WH.DRIVE
 Groupe ENTRAIN.ROUE AV

Stückzahl nach Ausführung / Quantity per model /
 Nombre par modèle
 2094 001 19.05.93

Bild Nr. Fig. No. Fig. No.	Teilnummer Partnumber No. de pièce	Benennung	Description	Désignation	Änderung Modification Modification	alle all tous	2094 001			19.05.93							
							019	020	021								
020	2094 346 033	ANTRIEBSWELLE	INPUT SHAFT	ARBRE D'ENTREE			1	1	1								
040	0631 610 070 M 6 X 8 DIN 913 8.8	GEWINDESTIFT	SET SCREW	GOUJON FILETE			1	1	1								
080	2094 346 034	KUPPLUNGSGLOCKE	BELL HOUSING	CLOCHE D'EMBR.			1	1	1								
100	0630 501 041 60X2 DIN 471	SICHERUNGSRING	RETAINING RING	JONC D'ARRET			2	2	2								
120	2094 346 008	SCHEIBE	WASHER	RONDELLE			1	1	1								
140	2094 246 014	AUSSENLAMELLE	O.CLUTCH DISC	DISQUE EXT.			8	8	8								
160	2002 302 055	INNENLAMELLE	I.CLUTCH DISC	DISQUE INT.			7	7	7								
180	2094 346 009	ENDSCHEIBE	END SHIM	RONDELLE			1	1	1								
200	0630 501 345 107X4 A107	SICHERUNGSRING	RETAINING RING	JONC D'ARRET			1	1	1								
220	2094 346 013	ABSCHIRMBLECH	SCREEN SHEET	TOLE DE PROT.			1	1	1								
240	2094 346 014	ABSCHIRMBLECH	SCREEN SHEET	TOLE DE PROT.			1	1	1								
260	0634 402 118 45 X 2 DIN 34110	R-RING SH	PISTON RING	SEGMENT			2	2	2								
280	2094 346 040	KOLBEN	PISTON	PISTON			1	1	1								
300	0734 307 170	LIPPENDICHTRING	LIP SEAL.RING	BAGUE ETANCH.L.			1	1	1								
320	0734 307 211	LIPPENDICHTRING	LIP SEAL.RING	BAGUE ETANCH.L.			1	1	1								
340	2094 346 035	BOLZEN	PIN	AXE			3	3	3								
360	0634 313 507 7 X 2,5 ZFN 744 ACM -70-10	O-RING	O-RING	JOINT TORIQUE			3	3	3								

Gruppe 2094 146 VORDERRADANTR.
 Group FRONT WH.DRIVE
 Groupe ENTRAIN.ROUE AV

Stückzahl nach Ausführung / Quantity per model /
 Nombre par modèle
 2094 001 19.05.93

Bild Nr. Fig. No. Fig. No.	Teilnummer Partnumber No. de pièce	Benennung	Description	Désignation	Änderung Modification Modification	Stückzahl nach Ausführung / Quantity per model / Nombre par modèle													
						alle all tous	019	020	021										
380	0501 312 384	TELLERFEDER	CUP SPRING	RONDELLE BELLEV			2	2	2										
400		SCHEIBE WAHLWEISE	WASHER OPTIONAL	RONDELLE EN OPTION															
	0730 108 857	S=4,0					1	1	1										
	0730 107 794	S=4,5					1	1	1										
	0730 108 858	S=5,0					1	1	1										
420	0630 531 080 65X4 DIN 471	SICHERUNGSRING	RETAINING RING	JONC D'ARRET			1	1	1										
440	0730 107 679	SCHEIBE	WASHER	RONDELLE			1	1	1										
460	0635 416 038	ROLLENLAGER	ROLLER BEARING	ROULEM.A ROUL.			1	1	1										
480	2094 346 012	DELZUFUEHRING					1	1	1										
500	0630 502 039 80X2,5 DIN 472	SICHERUNGSRING	RETAINING RING	JONC D'ARRET			1	1	1										
520	0634 402 540 35 X 2 DIN 34118	R-RING SH P KA	PISTON RING	SEGMENT			2	2	2										
540	0735 450 048	ROLLENLAGER	ROLLER BEARING	ROULEM.A ROUL.			1	1	1										
560	0630 502 034 68X2,5 DIN 472	SICHERUNGSRING	RETAINING RING	JONC D'ARRET			1	1	1										
580		AUSGL.SCHEIBE WAHLWEISE	SHIM OPTIONAL	RONDELLE EN OPTION															
	0730 107 908	A=2,90					1	1	1										
	0730 107 907	A=2,75					1	1	1										
	0730 107 906	A=2,60					1	1	1										
	0730 107 905	A=2,45					1	1	1										
	0730 107 904	A=2,30					1	1	1										
	0730 107 903	A=2,15					1	1	1										
	0730 107 902	A=2,00					1	1	1										
	0730 107 901	A=1,85					1	1	1										
	0730 107 900	A=1,70					1	1	1										
	0730 107 452	A=1,55					1	1	1										

ZFP-075.00 02/92 30.000

Gruppe 2094 146 VORDERRADANTR.
 Group FRONT WH.DRIVE
 Groupe ENTRAIN.ROUE AV

Stückzahl nach Ausführung / Quantity per model /
 Nombre par modèle

2094 001

19.05.93

Bild Nr. Fig. No. Fig. No.	Teilnummer Partnumber No. de pièce	Benennung	Description	Désignation	Änderung Modification Modification	alle all tous	Stückzahl nach Ausführung / Quantity per model / Nombre par modèle											
							019	020	021									
	0730 107 449	A=1,40					1	1	1									
600	0750 111 175	WELLENDICHTRING	SHAFT SEAL	BAGUE ETANCH.			1	1	1									
610	2094 246 012	ZAHNRAD	GEAR	PIGNON			1	1	1									
620	2094 304 050 KPL. Z=26	ZAHNRAD	GEAR	PIGNON			1	1	1									

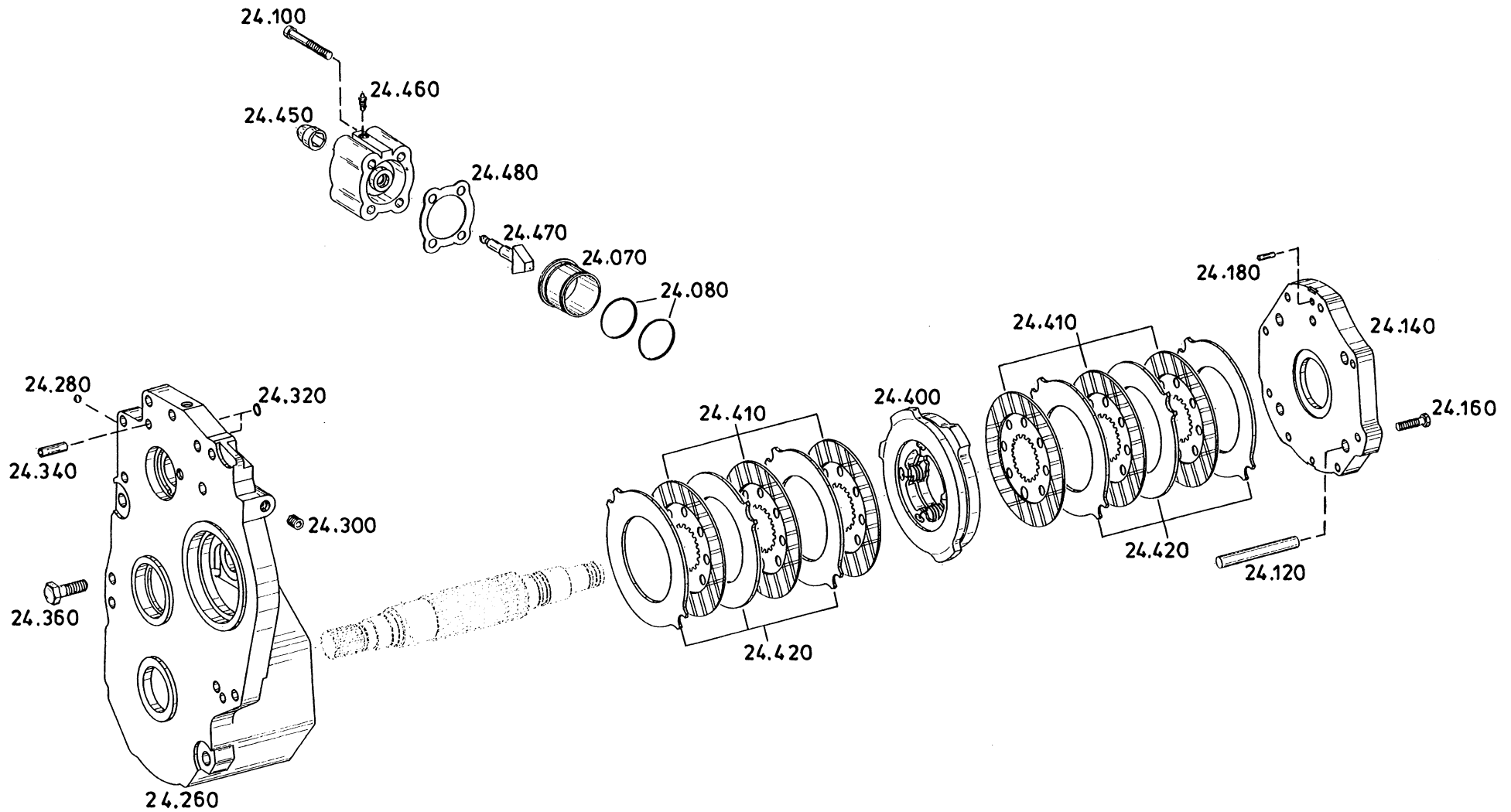

Die Abbildungen sind für die Ausführung nicht verbindlich
Illustrations are not binding for the design
Les illustrations ne sont pas obligatoires pour l'exécution

Gruppe 2094 124 BETR.BREMSE
 Group SERVICE BRAKE
 Groupe FREIN SERVICE

Stückzahl nach Ausführung / Quantity per model /
 Nombre par modèle

2094 001

19.05.93

Bild Nr. Fig. No. Fig. No.	Teilnummer Partnumber No. de pièce	Benennung	Description	Désignation	Änderung Modification Modification	alle all tous									
						019	020	021							
---	0501 004 720	BREMSE KPL. BESTEHEND AUS BILD NR. 400-420	BRAKE CPL. CONSISTING OF FIG NO. 400-420	FREIN CPL. COMPOSE DE FIG NO. 400-420			1	1	1						
400	0501 209 289	BETAETIGUNGSSCHEIBE KPL.	ACTUATOR PLATE CPL.	RONDELLE CDE CPL.			1	1	1						
410	0501 314 650	BELAGLAMELLE	LIN. CLUTCH DISC	DISQUE GARNIT.			6	6	6						
420	0501 314 651	AUSENLAMELLE	G.CLUTCH DISC	DISQU EXT.			6	6	6						
---	0501 004 721	BREMZYLINDER KPL. BESTEHEND AUS BILD NR. 450-480	BRAKE CYLINDER CPL. CONSISTING OF FIG NO. 450-480	CYLINDRE FREIN CPL. COMPOSE DE FIG NO. 450-480			1	1	1						
450	0501 314 646	SCHUTZKAPPE	PROTECTING CAP	CAPUCHON DE PROTECTION			1	1	1						
460	0501 209 288	ENTLUEFTERVENTIL KPL.	VENT VALVE CPL.	SOUP. PURGE AIR CPL.			1	1	1						
470	0501 314 648	DRUCKKEIL	PRESSURE PIECE	POUSSOIR			1	1	1						
480	0501 314 649	DICHTUNG	GASKET	JOINT			1	1	1						

Gruppe 2094 124 BETR.BREMSE
 Group SERVICE BRAKE
 Groupe FREIN SERVICE

Stückzahl nach Ausführung / Quantity per model /
 Nombre par modèle

2094 001

19.05.93

Bild Nr. Fig. No. Fig. No.	Teilnummer Partnumber No. de pièce	Benennung	Description	Désignation	Änderung Modification Modification	alle all tous	2094 001			19.05.93							
							019	020	021								
070	2094 324 007	BUCHSE	BUSH	DOUILLE			1	1	1								
080	0634 306 271 57 X 2,5 ZFN 744 NBR -70-10	O-RING	O-RING	JOINT TORIQUE			2	2	2								
100	0636 101 335 M 8 X 80 DIN 912 10.9	ZYL.SCHRAUBE	CAP SCREW	VIS TETE CYL.			4	4	4								
120	0731 201 559	BOLZEN	PIN	AXE			4	4	4								
140	2094 324 006	SCHEIBE	WASHER	RONDELLE			1	1	1								
160	0636 010 459 M 10 X 45 DIN 931 10.9	6KT.SCHRAUBE	HEXAGON SCREW	VIS HEXAGONALE			8	8	8								
180	0631 306 071 10 M 6X 16 ZFN 6 ST50K * 9S20K	ZYLINDERSTIFT	CYLINDRICAL PIN	GOUPILLE CYL.			2	2	2								
260	2094 301 025	DECKEL	COVER	COUVERCLE			1	1	1								
280	0635 460 021	KUGEL	BALL	BILLE			8	8	8								
300	0631 610 128 M 14 X 12 DIN 913 45H	GEWINDESTIFT	SET SCREW	GOUJON FILETE			3	3	3								
320	0634 303 085 12 X 3 ZFN 744 NBR -70-10	O-RING	O-RING	JOINT TORIQUE			2	2	2								
340	0631 315 561 C 12 X 45 DIN 7979	STIFT	PIN	GOUPILLE			2	2	2								
360	0636 011 024 M 12 X 50 DIN 931 10.9	6KT.SCHRAUBE	HEXAGON SCREW	VIS HEXAGONALE			10	10	10								

ZFP-075.00 02/92 30.000

Gruppe 2094 106 SCHALTUNG
 Group GEARSHIFT SYST.
 Groupe CHANGEMT.VIT.

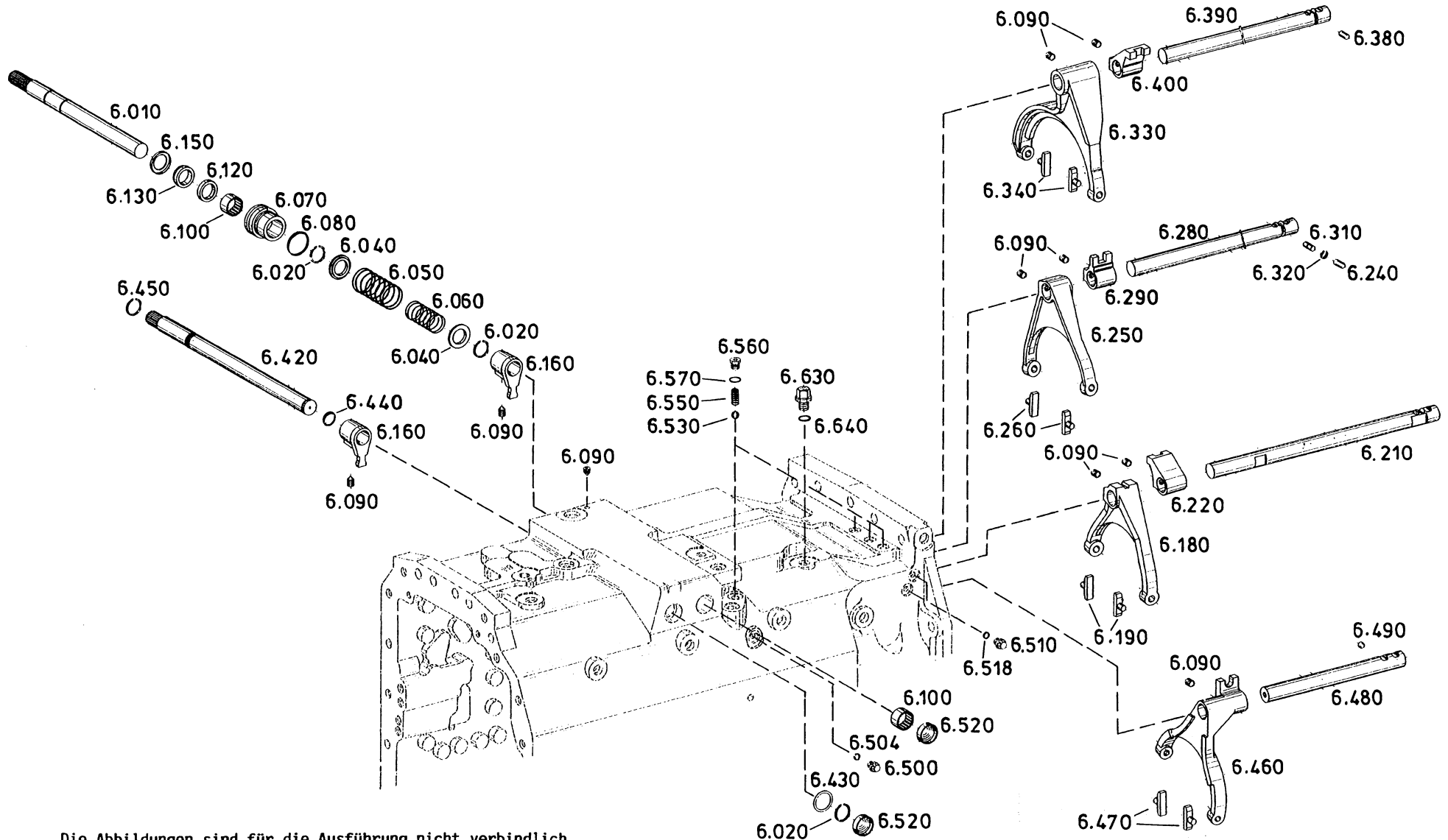

Die Abbildungen sind für die Ausführung nicht verbindlich
 Illustrations are not binding for the design
 Les illustrations ne sont pas obligatoires pour l'exécution

Gruppe 2094 106 SCHALTUNG
 Group GEARSHIFT SYST.
 Groupe CHANGEMT.VIT.

Stückzahl nach Ausführung / Quantity per model /
 Nombre par modèle

2094 001

19.05.93

Bild Nr. Fig. No. Fig. No.	Teilnummer Partnumber No. de pièce	Benennung	Description	Désignation	Änderung Modification Modification	Stückzahl nach Ausführung / Quantity per model / Nombre par modèle														
						alle all tous	019	020	021											
010	2094 306 042	SCHALTWELLE	G.SHIFT SHAFT	ARBRE CDE VIT.			1	1	1											
020	0630 513 070 SW 25	SPRENGRING	SNAP RING	CIRCLIP			3	3	3											
040	2094 306 019	SCHEIBE	WASHER	RONDELLE			2	2	2											
050	0732 040 444	DRUCKFEDER	COMPR.SPRING	RESSORT PRESS.			1	1	1											
060	0732 040 728	DRUCKFEDER	COMPR.SPRING	RESSORT PRESS.			1	1	1											
070	2094 306 014	BUCHSE	BUSH	DOUILLE			1	1	1											
080	0634 304 355 37 X 3 ZFN 744 NBR -70-10	O-RING	O-RING	JOINT TORIQUE			1	1	1											
090	1238 306 065	GEWINDESTIFT	SET SCREW	GOUJON FILETE			19	19	19											
100	0635 303 053	NADELHUELSE	NEEDLE SLEEVE	DOUILLE A AIG.			2	2	2											
120	0634 301 303 25 X 35X 7 ZFN 132 NB	WELLENDICHRING A	SHAFT SEAL	BAGUE ETANCH.			1	1	1											
130	0634 307 367 AS 25X 35X 7	ABSTREIFER X10	ROD WIPER	RACLEUR			1	1	1											
150	2094 306 020	SCHUTZRING	PROTECTING RING	BAGUE PROTECTR.			1	1	1											
160	2094 306 036	SCHALTFINGER	G.SHIFT FINGER	DOIGT DE CDE			2	2	2											
180	2094 306 004	SCHALTGABEL	GEAR SHIFT FORK	FOURCH.PASS.VIT			1	1	1											
190	1290 306 066	GLEITSTEIN	SLIDING PAD	COULISSEAU			2	2	2											
210	2094 306 037	SCHALTSCHIENE	GEAR SHIFT RAIL	GLISSIERE CDE			1	1	1											
220	2094 306 008	MITNEHMER	DRIVER	ENTRAINEUR			1	1	1											
240	0731 208 205	SPERRSTIFT	LOCKING PIN	GOUP. D'ARRET			1	1	1											

ZFP-075.00 02/92 30.000

Gruppe 2094 106 SCHALTUNG
 Group GEARSHIFT SYST.
 Groupe CHANGEMT.VIT.

Stückzahl nach Ausführung / Quantity per model /
 Nombre par modèle
 2094 001 19.05.93

Bild Nr. Fig. No. Fig. No.	Teilnummer Partnumber No. de pièce	Benennung	Description	Désignation	Änderung Modification Modification	alle all tous	2094 001			19.05.93								
							019	020	021									
250	2094 306 003	SCHALTGABEL	GEAR SHIFT FORK	FOURCH.PASS.VIT			1	1	1									
260	1290 306 066	GLEITSTEIN	SLIDING PAD	COULISSEAU			2	2	2									
280	2094 306 028	SCHALTSCHIENE	GEAR SHIFT RAIL	GLISSIERE CDE			1	1	1									
290	2094 306 007	MITNEHMMER					1	1	1									
310	0731 201 193	SPERRSTIFT	LOCKING PIN	GOUP. D'ARRET			1	1	1									
320	0630 505 559 B 7 DIN 7993	SPRENGRING	SNAP RING	CIRCLIP			1	1	1									
330	2094 306 029	SCHALTGABEL	GEAR SHIFT FORK	FOURCH.PASS.VIT			1	1	1									
340	1290 306 066	GLEITSTEIN	SLIDING PAD	COULISSEAU			2	2	2									
380	0731 208 225	SPERRSTIFT	LOCKING PIN	GOUP. D'ARRET			1	1	1									
390	2094 306 030	SCHALTSCHIENE	GEAR SHIFT RAIL	GLISSIERE CDE			1	1	1									
400	2094 306 032	MITNEHMER	DRIVER	ENTRAINEUR			1	1	1									
420	2094 306 041	SCHALTWELLE	G.SHIFT SHAFT	ARBRE CDE VIT.			1	1	1									
430	0730 003 739	SCHEIBE	WASHER	RONDELLE			1	1	1									
440	0634 303 199 20 X 3 ZFN 744 NBR -70-10	O-RING	O-RING	JOINT TORIQUE			1	1	1									
450	0630 505 527 A 25 DIN 7993	SPRENGRING	SNAP RING	CIRCLIP			1	1	1									
460	2094 306 038	SCHALTGABEL	GEAR SHIFT FORK	FOURCH.PASS.VIT			1	1	1									
470	1290 306 066	GLEITSTEIN	SLIDING PAD	COULISSEAU			2	2	2									
480	2094 306 039	SCHALTSCHIENE	GEAR SHIFT RAIL	GLISSIERE CDE			1	1	1									
490	0731 208 206	SPERRSTIFT	LOCKING PIN	GOUP. D'ARRET			1	1	1									

Gruppe 2094 106 SCHALTUNG
 Group GEARSHIFT SYST.
 Groupe CHANGEMT.VIT.

Stückzahl nach Ausführung / Quantity per model /
 Nombre par modèle

2094 001

19.05.93

Bild Nr. Fig. No. Fig. No.	Teilnummer Partnumber No. de pièce	Benennung	Description	Désignation	Änderung Modification Modification	Stückzahl nach Ausführung / Quantity per model / Nombre par modèle														
						alle all tous	019	020	021											
500	0636 304 019 M 10X1 DIN 910 ST FE/ZNPHR8F	VERSCHL.SCHR.	SCREW PLUG	VIS FERMETURE			1	1	1											
504	0634 303 280 8 X 1,5 ZFN 744 NBR -70-10	O-RING	O-RING	JOINT TORIQUE			1	1	1											
510	0736 304 151	VERSCHL.SCHR.	SCREW PLUG	VIS FERMETURE			2	2	2											
518	0634 303 280 8 X 1,5 ZFN 744 NBR -70-10	O-RING	O-RING	JOINT TORIQUE			2	2	2											
520	0630 361 039 32 DIN 443 FE/ZNPHR8F	VERSCHL.DECKEL	SEALING CAP	COUVERCLE			2	2	2											
530	0635 460 021	KUGEL	BALL	BILLE			4	4	4											
550	1203 313 004	DRUCKFEDER	COMPR.SPRING	RESSORT PRESS.			4	4	4											
560	0636 302 001 M 12X1,5 DIN 908 ST	VERSCHL.SCHR.	SCREW PLUG	VIS FERMETURE			4	4	4											
570	0634 303 144 9,5 X 2 ZFN 744 NBR -70-10	O-RING	O-RING	JOINT TORIQUE			4	4	4											
630	0636 305 011 AM 18X1,5 DIN 7604 ST	VERSCHL.SCHR.	SCREW PLUG	VIS FERMETURE			1	1	1											

ZFP-075.00 02/92 30.000

Gruppe 2094 106 SCHALTUNG
 Group GEARSHIFT SYST.
 Groupe CHANGEMT.VIT.

Stückzahl nach Ausführung / Quantity per model /
 Nombre par modèle

2094 001

19.05.93

Bild Nr. Fig. No. Fig. No.	Teilnummer Partnumber No. de pièce	Benennung	Description	Désignation	Änderung Modification Modification	Stückzahl nach Ausführung / Quantity per model / Nombre par modèle														
						alle all tous	019	020	021											
640	0634 306 524 15 X 2 ZFN 744 NBR -70-10	O-RING	O-RING	JOINT TORIQUE			1	1	1											

Gruppe 2094 152 SCHALTUNG
 Group GEARSHIFT SYST.
 Groupe CHANGEMT.VIT.

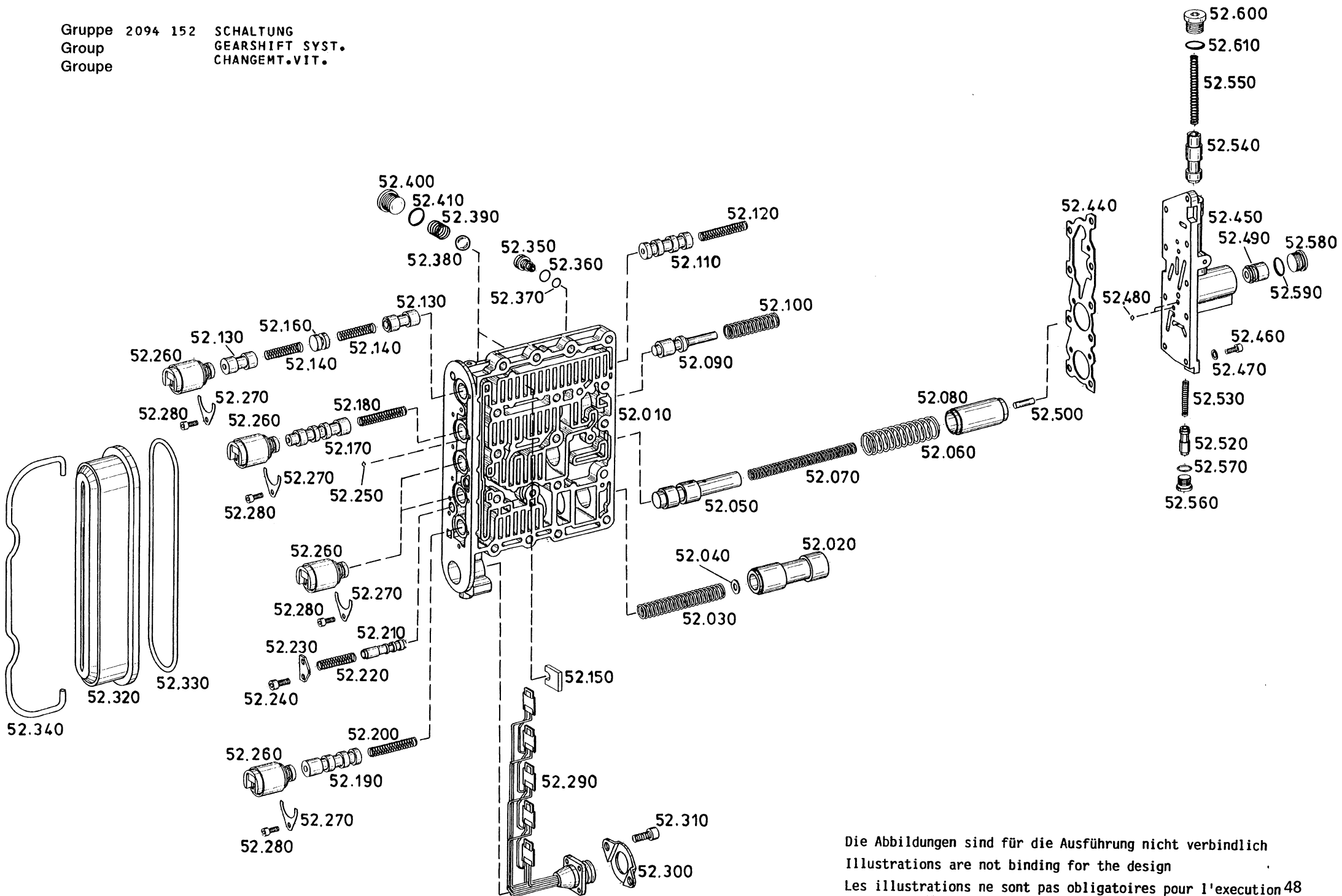

Die Abbildungen sind für die Ausführung nicht verbindlich
 Illustrations are not binding for the design
 Les illustrations ne sont pas obligatoires pour l'exécution 48

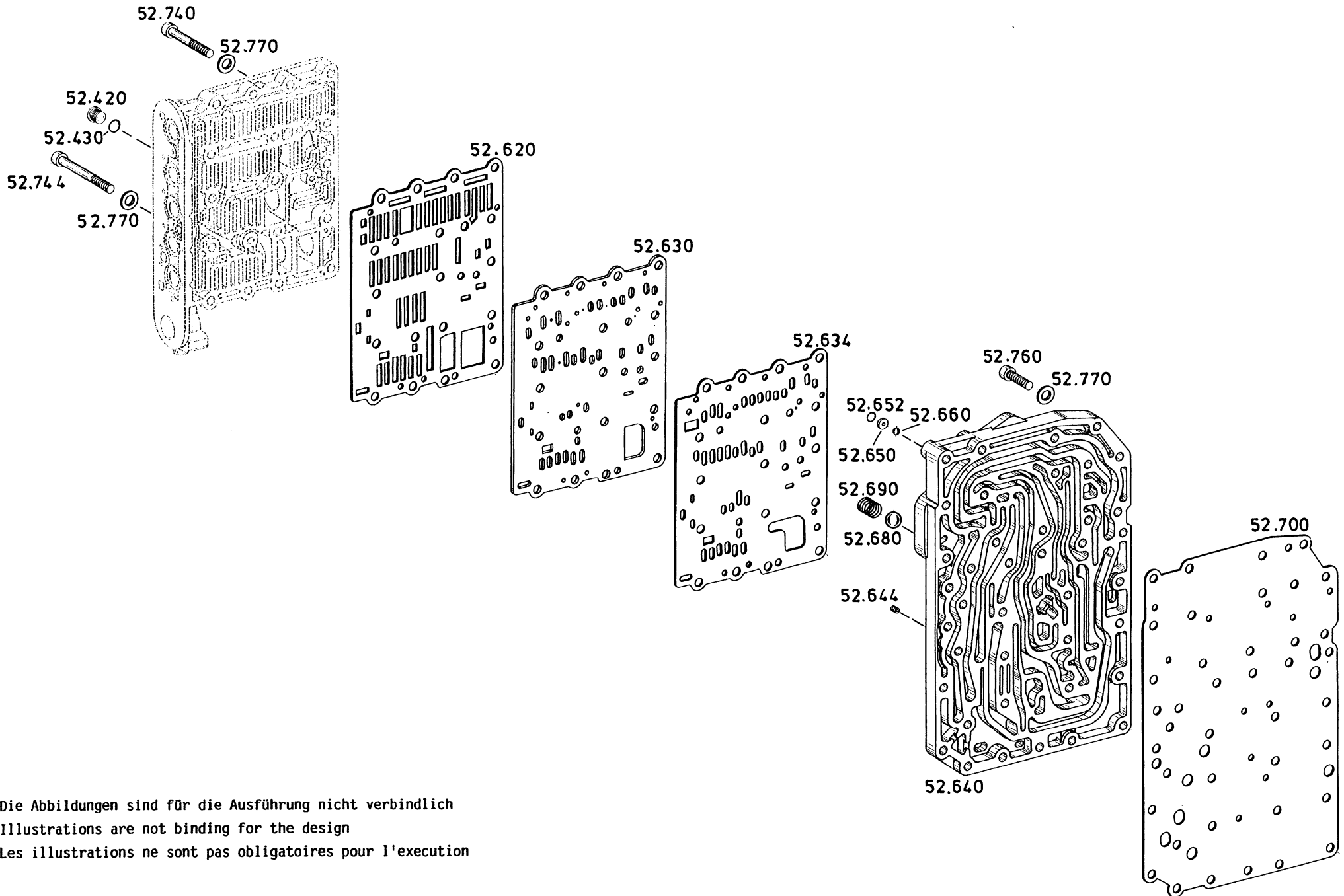

Die Abbildungen sind für die Ausführung nicht verbindlich
Illustrations are not binding for the design
Les illustrations ne sont pas obligatoires pour l'exécution

Gruppe 2094 152 SCHALTUNG
 Group GEARSHIFT SYST.
 Groupe CHANGEMT.VIT.

Stückzahl nach Ausführung / Quantity per model /
 Nombre par modèle

2094 001

19.05.93

Bild Nr. Fig. No. Fig. No.	Teilnummer Partnumber No. de pièce	Benennung	Description	Désignation	Änderung Modification Modification	alle all tous	Stückzahl nach Ausführung / Quantity per model / Nombre par modèle										
							019	020	021								
010	2094 352 024	VENTILGEHAEUSE	VALVE HOUSING	CARTER DE VALVE			1	1	1								
020	2093 352 030	KOLBEN	PISTON	PISTON			1	1	1								
030	0732 042 446	DRUCKFEDER	COMPR.SPRING	RESSORT PRESS.			1	1	1								
	2094 352 042	STIFT	PIN	GOUPILLE			1	1	1								
	0732 040 889	DRUCKFEDER	COMPR.SPRING	RESSORT PRESS.			1	1	1								
040		SCHEIBE WAHLWEISE	WASHER OPTIONAL	RONDELLE EN OPTION													
	0630 000 185 10X 16 X0,2 DIN 988						1	1	1								
	0630 000 164 10X 16 X0,3 DIN 988						1	1	1								
	0630 000 148 10X 16 X0,4 PS						1	1	1								
	0630 004 038 10X 16 X0,5 DIN 988						1	1	1								
	0630 004 037 10X 16 X1 DIN 988						1	1	1								
050	2093 352 043	KOLBEN	PISTON	PISTON			1	1	1								
060	0732 042 315	DRUCKFEDER	COMPR.SPRING	RESSORT PRESS.			1	1	1								
070	0732 042 316	DRUCKFEDER	COMPR.SPRING	RESSORT PRESS.			1	1	1								
080	4644 306 377	KOLBEN	PISTON	PISTON			1	1	1								
090	4644 306 509	KOLBEN	PISTON	PISTON			1	1	1								
100	0732 042 317	DRUCKFEDER	COMPR.SPRING	RESSORT PRESS.			1	1	1								
110	2093 352 034	KOLBEN	PISTON	PISTON			1	1	1								
120	0732 042 025	DRUCKFEDER	COMPR.SPRING	RESSORT PRESS.			1	1	1								
130	2093 352 036	KOLBEN	PISTON	PISTON			2	2	2								

Gruppe 2094 152 SCHALTUNG
 Group GEARSHIFT SYST.
 Groupe CHANGEMT.VIT.

Stückzahl nach Ausführung / Quantity per model /
 Nombre par modèle

2094 001

19.05.93

Bild Nr. Fig. No. Fig. No.	Teilnummer Partnumber No. de pièce	Benennung	Description	Désignation	Anderung Modification Modification	Stückzahl nach Ausführung / Quantity per model / Nombre par modèle														
						alle all tous	019	020	021											
140	0732 040 597	DRUCKFEDER	COMPR.SPRING	RESSORT PRESS.			2	2	2											
150	4644 306 234	ANSCHLAGBLECH	STOP PLATE	TOLE D'ARRET			1	1	1											
160	4644 306 267	ANSCHLAG	STOP	BUTEE			1	1	1											
170	2093 352 003	KOLBEN	PISTON	PISTON			1	1	1											
180	0732 042 025	DRUCKFEDER	COMPR.SPRING	RESSORT PRESS.			1	1	1											
190	2093 352 042	KOLBEN	PISTON	PISTON			1	1	1											
200	0732 042 025	DRUCKFEDER	COMPR.SPRING	RESSORT PRESS.			1	1	1											
210	2093 352 015	REDUZIERVERTIL	REDUCTION VALVE	DETENDEUR			1	1	1											
220	0732 042 024	DRUCKFEDER	COMPR.SPRING	RESSORT PRESS.			1	1	1											
230	4644 306 386	HALTEBLECH	FIXING PLATE	TOLE SUPPORT			1	1	1											
240	0636 101 107 M 5 X 10 DIN 912 8.8	ZYL.SCHRAUBE	CAP SCREW	VIS TETE CYL.			2	2	2											
250	0635 460 005	KUGEL	BALL	BILLE			10	10	10											
260	0501 311 654	MAGNETVENTIL	SOLENOID VALVE	ELECTROVANNE			5	5	5											
270	1043 326 045	HALTEBLECH	FIXING PLATE	TOLE SUPPORT			5	5	5											
280	0636 101 107 M 5 X 10 DIN 912 8.8	ZYL.SCHRAUBE	CAP SCREW	VIS TETE CYL.			5	5	5											
290	2093 252 002	KABELBAUM	WIRING HARNESS	FAISCEAU CABLES			1	1	1											
300	4644 306 399	HALTEBLECH	FIXING PLATE	TOLE SUPPORT			1	1	1											
310	0636 101 478 M 6 X 14 DIN 912 8.8	ZYL.SCHRAUBE	CAP SCREW	VIS TETE CYL.			2	2	2											

Gruppe 2094 152 SCHALTUNG
 Group GEARSHIFT SYST.
 Groupe CHANGEMT.VIT.

Stückzahl nach Ausführung / Quantity per model /
 Nombre par modèle

2094 001

19.05.93

Bild Nr. Fig. No. Fig. No.	Teilnummer Partnumber No. de pièce	Benennung	Description	Désignation	Änderung Modification Modification	alle all tous	Stückzahl nach Ausführung / Quantity per model / Nombre par modèle											
							019	020	021									
320	4644 206 039	DECKEL	COVER	COUVERCLE			1	1	1									
330	0634 349 606 159,2 X 5,7	O-RING	O-RING	JOINT TORIQUE			1	1	1									
340	4644 306 388	SPANNBUEGEL	CLAMP.BRACKET	COLLIER SERRAGE			1	1	1									
350	2093 352 049 2093 352 047 2093 352 046	BLENDE WAHLWEISE	ORIFICE OPTIONAL	AJUTAGE EN OPTION			1	1	1									
360	0634 303 280 8 X 1,5 ZFN 744 NBR -70-10	O-RING	O-RING	JOINT TORIQUE			1	1	1									
370	0634 306 170 6 X 1,5 ZFN 744 NBR -70-10	O-RING	O-RING	JOINT TORIQUE			1	1	1									
380	0635 460 027	KUGEL	BALL	BILLE			2	2	2									
390	0732 041 226	DRUCKFEDER	COMPR.SPRING	RESSORT PRESS.			2	2	2									
400	0636 302 004 M 18X1,5 DIN 908 ST FE/ZNPHR8F	VERSCHL.SCHR.	SCREW PLUG	VIS FERMETURE			2	2	2									
410	0634 306 524 15 X 2 ZFN 744 NBR -70-10	O-RING	O-RING	JOINT TORIQUE			2	2	2									
420	0636 302 031 M 10X1 DIN 908 ST	VERSCHL.SCHR.	SCREW PLUG	VIS FERMETURE			13	13	13									

ZFP-075.00 02/92 30.000

Gruppe 2094 152 SCHALTUNG
 Group GEARSHIFT SYST.
 Groupe CHANGEMT.VIT.

Stückzahl nach Ausführung / Quantity per model /
 Nombre par modèle

2094 001

19.05.93

Bild Nr. Fig. No. Fig. No.	Teilnummer Partnumber No. de pièce	Benennung	Description	Désignation	Änderung Modification Modification	alle all tous	Stückzahl nach Ausführung / Quantity per model / Nombre par modèle											
							019	020	021									
430	0634 303 280 8 X 1,5 ZFN 744 NBR -70-10	O-RING	O-RING	JOINT TORIQUE			13	13	13									
440	4644 306 382	DICHTUNG	GASKET	JOINT			1	1	1									
450	4644 306 511	SCHALTGEHAEUSE	G.SHIFT HOUSING	CART.CDE VIT.			1	1	1									
460	0636 101 011 M 6 X 18 DIN 912 8.8	ZYL.SCHRAUBE	CAP SCREW	VIS TETE CYL.			9	9	9									
470	0630 003 004 6,4 DIN 433 200HV	SCHEIBE	WASHER	RONDELLE			9	9	9									
480	0635 460 005	KUGEL	BALL	BILLE			5	5	5									
490		KOLBEN WAHLWEISE	PISTON OPTIONAL	PISTON EN OPTION														
	2093 352 038	B=21					1	1	1									
	2093 352 037	B=20,5					1	1	1									
	2093 352 040	B=20,0					1	1	1									
	2093 352 048	B=19,5					1	1	1									
500	0635 470 104	WALZE	ROLLER	ROULEAU			1	1	1									
520	4644 306 397	KOLBEN	PISTON	PISTON			1	1	1									
530	0732 042 318	DRUCKFEDER	COMPR.SPRING	RESSORT PRESS.			1	1	1									
540	4644 306 398	KOLBEN	PISTON	PISTON			1	1	1									
550	0732 041 764	DRUCKFEDER	COMPR.SPRING	RESSORT PRESS.			1	1	1									
560	0636 302 001 M 12X1,5 DIN 908 ST	VERSCHL.SCHR.	SCREW PLUG	VIS FERMETURE			1	1	1									

Gruppe 2094 152 SCHALTUNG
 Group GEARSHIFT SYST.
 Groupe CHANGEMT.VIT.

Stückzahl nach Ausführung / Quantity per model /
 Nombre par modèle
 2094 001 19.05.93

Bild Nr. Fig. No. Fig. No.	Teilnummer Partnumber No. de pièce	Benennung	Description	Désignation	Änderung Modification Modification	alle all tous	Stückzahl nach Ausführung / Quantity per model / Nombre par modèle											
							019	020	021									
570	0634 303 144 9,5 X 2 ZFN 744 NBR -70-10	O-RING	O-RING	JOINT TORIQUE			1	1	1									
580	0636 302 005 M 20X1,5 DIN 908 ST	VERSCHL.SCHR.	SCREW PLUG	VIS FERMETURE			1	1	1									
590	0634 306 198 17 X 2 ZFN 744 NBR -70-10	O-RING	O-RING	JOINT TORIQUE			1	1	1									
600	2093 352 041	SCHRAUBE	SCREW	VIS			1	1	1									
610	0634 306 524 15 X 2 ZFN 744 NBR -70-10	O-RING	O-RING	JOINT TORIQUE			1	1	1									
620	2094 352 040	DICHTUNG	GASKET	JOINT			1	1	1									
630	2094 352 020	ZWISCHENBLECH	INTERM.SHEET	TOLE INTERM.			1	1	1									
634	2094 352 021	DICHTUNG	GASKET	JOINT			1	1	1									
640	2094 352 019	KANALPLATTE	DUCT PLATE	PLAQUE CANIVEAU			1	1	1									
644	4644 306 076	BLENDE	ORIFICE	AJUTAGE			1	1	1									
650	0730 150 663	SCHEIBE	WASHER	RONDELLE			1	1	1									
652	0634 313 266 7 X 1,5 ZFN 744 FPM -70-10	O-RING	O-RING	JOINT TORIQUE	35332		1	1	1									
	0634 306 169 7 X 1,5 ZFN 744 NBR -70-10	ANLAUFTEIL O-RING	INTRODUCTION DATE O-RING	MOMENT DE DEMARRAGE JOINT TORIQUE	35332		1	1	1									
		AUSLAUFTEIL	TERMINATING DATE	MOMENT DE TERMNAISON														

Gruppe 2094 152 SCHALTUNG
 Group GEARSHIFT SYST.
 Groupe CHANGEMT.VIT.

Stückzahl nach Ausführung / Quantity per model /
 Nombre par modèle
 2094 001 19.05.93

Bild Nr. Fig. No. Fig. No.	Teilnummer Partnumber No. de pièce	Benennung	Description	Désignation	Änderung Modification Modification	Stückzahl nach Ausführung / Quantity per model / Nombre par modèle															
						alle all tous	019	020	021												
660	0635 460 302	KUGEL	BALL	BILLE			1	1	1												
680	0635 460 027	KUGEL	BALL	BILLE			1	1	1												
690	0732 041 226	DRUCKFEDER	COMPR.SPRING	RESSORT PRESS.			1	1	1												
700	2094 352 022	DICHTUNG	GASKET	JOINT			1	1	1												
740	0736 101 205	ZYL.SCHRAUBE	CAP SCREW	VIS TETE CYL.			16	16	16												
744	0736 101 206	ZYL.SCHRAUBE	CAP SCREW	VIS TETE CYL.			1	1	1												
760	0736 101 202	ZYL.SCHRAUBE	CAP SCREW	VIS TETE CYL.			10	10	10												
770	0630 003 006 8,4 DIN 433 200HV	SCHEIBE	WASHER	RONDELLE			27	27	27												

Gruppe 2094 177 HYDR.SCHALTUNG
Group
Groupe

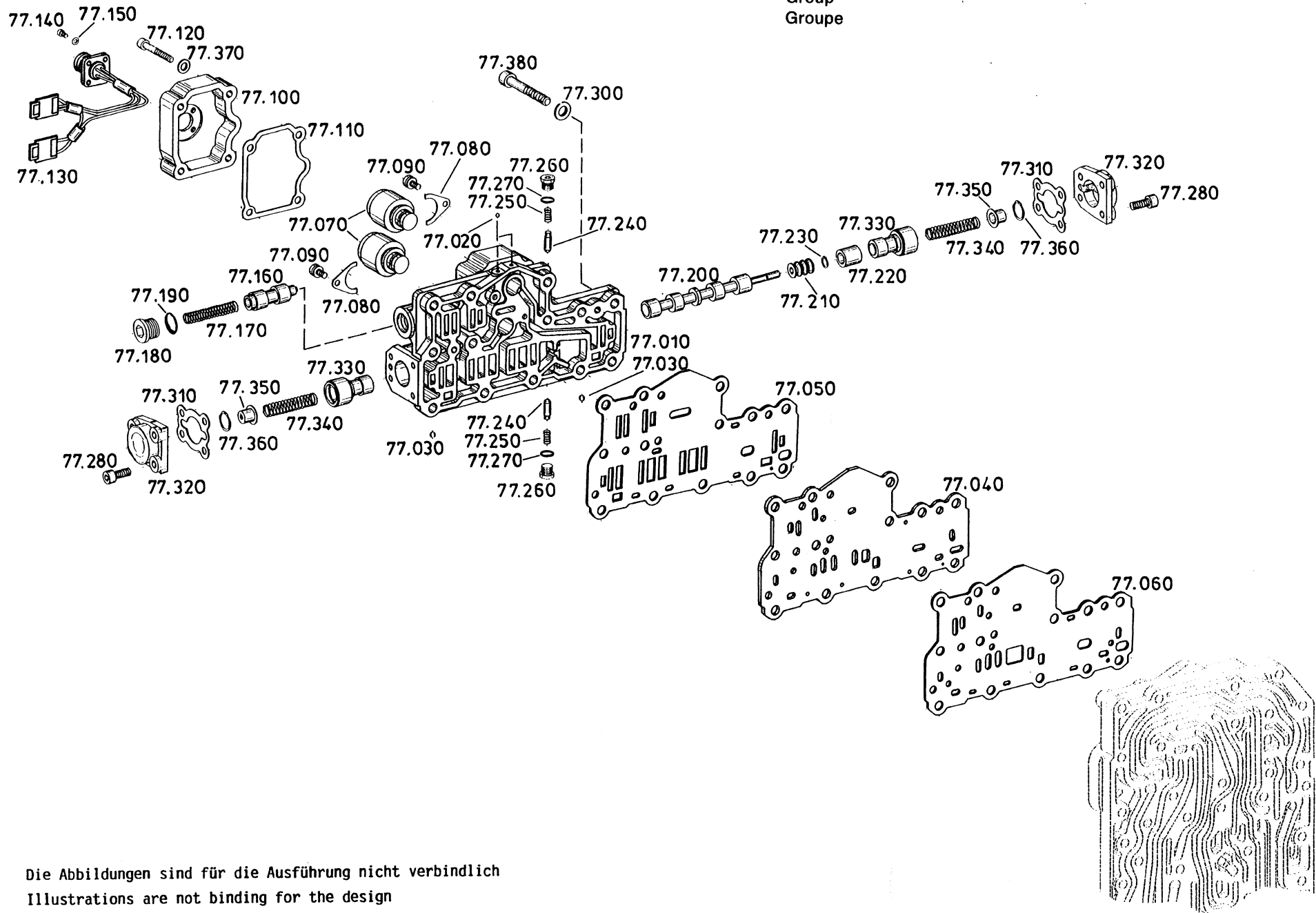

Die Abbildungen sind für die Ausführung nicht verbindlich
Illustrations are not binding for the design
Les illustrations ne sont pas obligatoires pour l'exécution

Gruppe 2094 177 HYDR.SCHALTUNG
 Group
 Groupe

Stückzahl nach Ausführung / Quantity per model /
 Nombre par modèle

2094 001

19.05.93

Bild Nr. Fig. No. Fig. No.	Teilnummer Partnumber No. de pièce	Benennung	Description	Désignation	Änderung Modification Modification	alle all tous	Stückzahl nach Ausführung / Quantity per model / Nombre par modèle												
							019	020	021										
010	2093 377 026	VENTILBLOCK	VALVE BLOCK	BLOC-VALVES			1	1	1										
020	0635 460 004	KUGEL	BALL	BILLE			2	2	2										
030	0635 460 010	KUGEL	BALL	BILLE			2	2	2										
040	2094 377 049	ZWISCHENPLATTE	INTERM.PLATE	PLAQUE INTERM.			1	1	1										
050	2094 377 050	DICHTUNG	GASKET	JOINT			1	1	1										
060	2094 377 051	DICHTUNG	GASKET	JOINT			1	1	1										
070	0501 311 654	MAGNETVENTIL	SOLENOID VALVE	ELECTROVANNE			2	2	2										
080	1043 326 045	HALTEBLECH	FIXING PLATE	TOLE SUPPORT			2	2	2										
090	0736 101 094	ZYL.SCHRAUBE	CAP SCREW	VIS TETE CYL.			2	2	2										
100	2093 377 013	DECKEL	COVER	COUVERCLE			1	1	1										
110	2093 377 016	DICHTUNG	GASKET	JOINT			1	1	1										
120	0636 101 017 M 6 X 35 DIN 912 8.8	ZYL.SCHRAUBE	CAP SCREW	VIS TETE CYL.			4	4	4										
130	2094 277 014	KABELBAUM	WIRING HARNESS	FAISCEAU CABLES			1	1	1										
140	0636 404 298 M 4 X 10 DIN 84 4.8 FE/ZN8C	ZYL.SCHRAUBE	CAP SCREW	VIS TETE CYL.			4	4	4										
150	0630 050 039 U 4,5 X 7	USITRING	USIT RING	BAGUE USIT			4	4	4										
160	2094 377 041	KOLBEN	PISTON	PISTON			1	1	1										
170	0732 042 329	DRUCKFEDER	COMPR.SPRING	RESSORT PRESS.			1	1	1										

ZFP-075.00 02/92 30.000

Gruppe 2094 177 HYDR.SCHALTUNG
 Group
 Groupe

Stückzahl nach Ausführung / Quantity per model /
 Nombre par modèle

2094 001

19.05.93

Bild Nr. Fig. No. Fig. No.	Teilnummer Partnumber No. de pièce	Benennung	Description	Désignation	Änderung Modification Modification	Stückzahl nach Ausführung / Quantity per model / Nombre par modèle														
						alle all tous	019	020	021											
180	0636 302 014 M 18X1,5 DIN 908 ST	VERSCHL.SCHR.	SCREW PLUG	VIS FERMETURE			1	1	1											
190	0634 306 524 15 X 2 ZFN 744 NBR -70-10	O-RING	O-RING	JOINT TORIQUE			1	1	1											
200	2093 377 021	KOLBEN	PISTON	PISTON			1	1	1											
210	2093 377 020	RASTE	DETENT	CRAN D'ARRET			1	1	1											
220	2093 377 022	KOLBEN	PISTON	PISTON			1	1	1											
230	0630 501 002 6X0,7 DIN 471	SICHERUNGSRING	RETAINING RING	JONC D'ARRET			1	1	1											
240	2093 377 009	KOLBEN	PISTON	PISTON			2	2	2											
250	0732 041 159	DRUCKFEDER	COMPR.SPRING	RESSORT PRESS.			2	2	2											
260	0636 302 031 M 10X1 DIN 908 ST	VERSCHL.SCHR.	SCREW PLUG	VIS FERMETURE			2	2	2											
270	0634 303 280 8 X 1,5 ZFN 744 NBR -70-10	O-RING	O-RING	JOINT TORIQUE			2	2	2											
280	0636 101 012 M 6 X 20 DIN 912 8.8	ZYL.SCHRAUBE	CAP SCREW	VIS TETE CYL.			8	8	8											
300	0630 003 006 8,4 DIN 433 200HV	SCHEIBE	WASHER	RONDELLE			13	13	13											

Gruppe 2094 177 HYDR.SCHALTUNG
 Group
 Groupe

Stückzahl nach Ausführung / Quantity per model /
 Nombre par modèle
 2094 001 19.05.93

Bild Nr. Fig. No. Fig. No.	Teilnummer Partnumber No. de pièce	Benennung	Description	Désignation	Änderung Modification Modification	alle all tous	Stückzahl nach Ausführung / Quantity per model / Nombre par modèle													
							019	020	021											
310	2093 377 014	DICHTUNG	GASKET	JOINT			2	2	2											
320	2093 377 012	DECKEL	COVER	COUVERCLE			2	2	2											
330	2093 377 023	KOLBEN	PISTON	PISTON			2	2	2											
340	0732 040 722	DRUCKFEDER	COMPR.SPRING	RESSORT PRESS.			2	2	2											
350	2093 377 024	KAPPE	CAP	CAPUCHON			2	2	2											
360	0630 532 140 JV 18	V-RING	V-RING	BAGUE-V			2	2	2											
370	0630 003 004 6,4 DIN 433 200HV	SCHEIBE	WASHER	RONDELLE			4	4	4											
380	0736 101 204	ZYL.SCHRAUBE	CAP SCREW	VIS TETE CYL.			13	13	13											

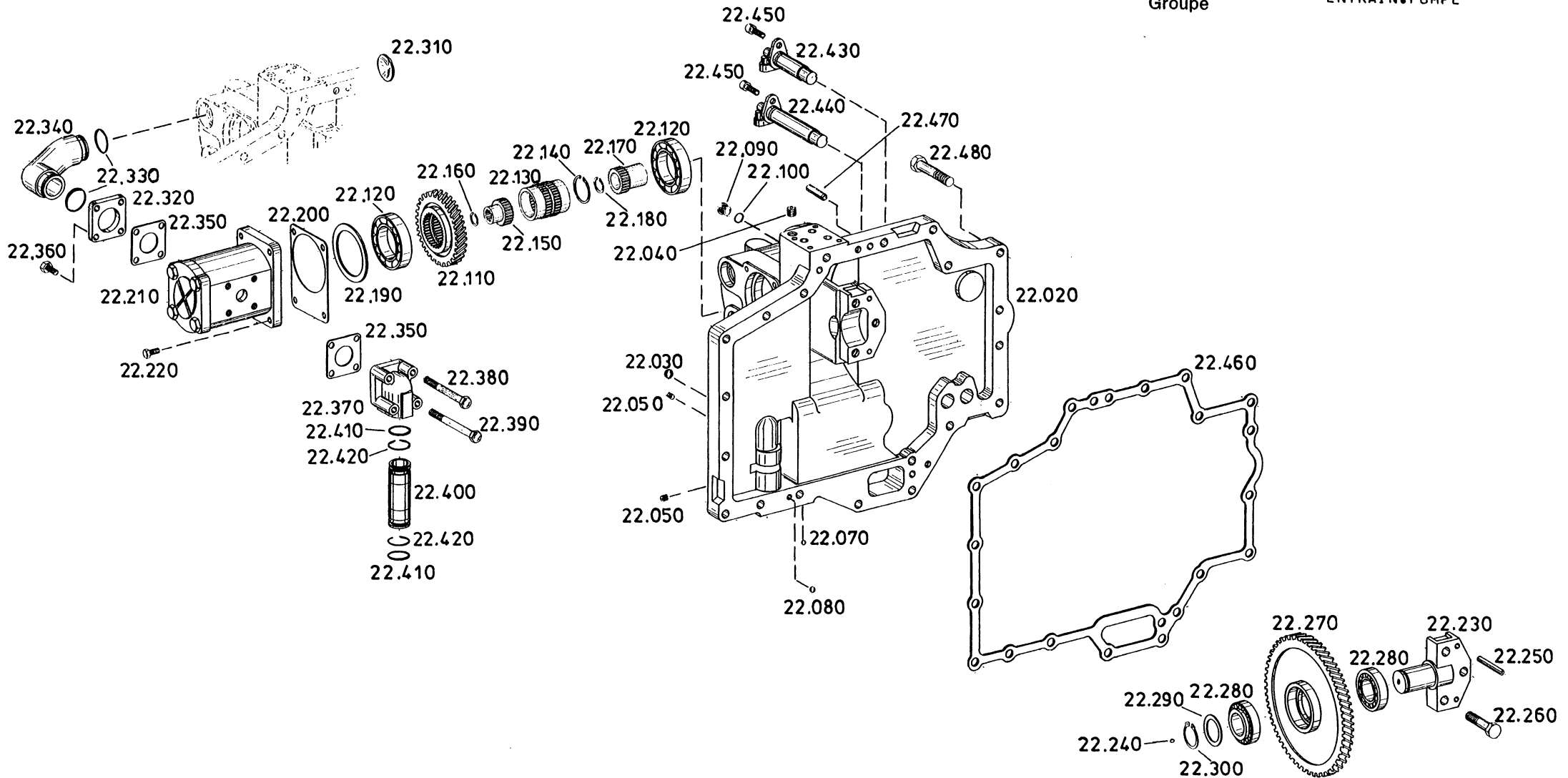

Die Abbildungen sind für die Ausführung nicht verbindlich
 Illustrations are not binding for the design
 Les illustrations ne sont pas obligatoires pour l'exécution

Gruppe 2094 122 PUMPENANTRIEB
 Group PUMP DRIVE
 Groupe ENTRAIN.POMPE

Stückzahl nach Ausführung / Quantity per model /
 Nombre par modèle

2094 001

19.05.93

Bild Nr. Fig. No. Fig. No.	Teilnummer Partnumber No. de pièce	Benennung	Description	Désignation	Änderung Modification Modification	alle all tous	Stückzahl nach Ausführung / Quantity per model / Nombre par modèle											
							019	020	021									
020	2094 322 040	GEHAEUSE	HOUSING	CARTER			1	1	1									
030	0635 460 023	KUGEL	BALL	BILLE			1	1	1									
040	0631 610 128 M 14 X12 DIN 913 45H	GEWINDESTIFT	SET SCREW	GOUJON FILETE			1	1	1									
050	0631 610 107 M 8 X 6 DIN 913 45H	GEWINDESTIFT	SET SCREW	GOUJON FILETE			2	2	2									
070	0635 460 012	KUGEL	BALL	BILLE			1	1	1									
080	0635 460 017	KUGEL	BALL	BILLE			1	1	1									
090	0636 302 031 M 10X1 DIN 908 ST	VERSCHL.SCHR.	SCREW PLUG	VIS FERMETURE			1	1	1									
100	0634 313 322 8 X 1,5 ZFN 744 FPM -70-10	O-RING	O-RING	JOINT TORIQUE			1	1	1									
110	2094 322 034 Z=39 2094 322 035 Z=41	STIRNRAD	SPUR GEAR	PIGNON CYLINDR.			1	1										
120	0750 116 176	KUGELLAGER	BALL BEARING	ROULEM.A BILLES			2	2	2									
130	2094 322 027	BUCHSE	BUSH	DOUILLE			1	1	1									
140	0630 502 018 35X1,5 DIN 472	SICHERUNGSRING	RETAINING RING	JONC D'ARRET			1	1	1									
150	2094 322 028	BUCHSE	BUSH	DOUILLE			1	1	1									

ZFP-075.00 02/92 30.000

Gruppe 2094 122 PUMPENANTRIEB
 Group PUMP DRIVE
 Groupe ENTRAIN.POMPE

Stückzahl nach Ausführung / Quantity per model /
 Nombre par modèle

2094 001

19.05.93

Bild Nr. Fig. No. Fig. No.	Teilnummer Partnumber No. de pièce	Benennung	Description	Désignation	Änderung Modification Modification	Stückzahl nach Ausführung / Quantity per model / Nombre par modèle														
						alle all tous	019	020	021											
160	0630 502 002 14X1 DIN 472	SICHERUNGSRING	RETAINING RING	JONC D'ARRET			1	1	1											
170	2094 322 029	BUCHSE	BUSH	DOUILLE			1	1	1											
180	0630 502 007 20X1 DIN 472	SICHERUNGSRING	RETAINING RING	JONC D'ARRET			1	1	1											
190		SCHEIBE WAHLWEISE	WASHER OPTIONAL	RONDELLE EN OPTION																
	1232 304 063	S=0,9					1	1	1											
	1232 304 066	S=1,2					1	1	1											
	1232 304 050	S=1,5					1	1	1											
	1232 304 059	S=1,8					1	1	1											
	1232 304 032	S=2,1					1	1	1											
	1232 304 061	S=2,4					1	1	1											
	1232 304 085	S=2,6					1	1	1											
	0730 109 066	S=2,9					1	1	1											
	0730 109 067	S=3,2					1	1	1											
200	2052 322 097	DICHTUNG	GASKET	JOINT			1	1	1											
210	0501 003 848	PUMPE	PUMP	POMPE			1													
	0501 004 477	PUMPE	PUMP	POMPE					1	1										
220	0636 010 066 M 8 X 30 DIN 933 8.8	6KT.SCHRAUBE	HEXAGON SCREW	VIS HEXAGONALE			4													
	0636 015 089 M 8 X 25 DIN 933 8.8	6KT.SCHRAUBE	HEXAGON SCREW	VIS HEXAGONALE					4	4										
230	2094 322 032	LAGERBOCK	BRACKET	SUPPORT			1	1	1											
240	0635 460 010	KUGEL	BALL	BILLE			1	1	1											

Gruppe 2094 122 PUMPENANTRIEB
 Group PUMP DRIVE
 Groupe ENTRAIN.POMPE

Stückzahl nach Ausführung / Quantity per model /
 Nombre par modèle
 2094 001 19.05.93

Bild Nr. Fig. No. Fig. No.	Teilnummer Partnumber No. de pièce	Benennung	Description	Désignation	Änderung Modification Modification	Stückzahl nach Ausführung / Quantity per model / Nombre par modèle														
						alle all tous	019	020	021											
250	0631 306 754 8 M 6X 36 ZFN 6 16MNCR5 E	ZYLINDERSTIFT	CYLINDRICAL PIN	GOUPILLE CYL.			2	2	2											
260	0636 011 356 M 12 X 45 DIN 931 10.9	6KT.SCHRAUBE	HEXAGON SCREW	VIS HEXAGONALE			3	3	3											
270	2094 322 036 Z=75	STIRNRAD	SPUR GEAR	PIGNON CYLINDR.																
	2094 322 037 Z=77	STIRNRAD	SPUR GEAR	PIGNON CYLINDR.			1	1												
280	0635 370 039	ROLLENLAGER	ROLLER BEARING	ROULEM.A ROUL.			2	2	2											
290		AUSGL.SCHEIBE WAHLWEISE	SHIM OPTIONAL	RONDELLE EN OPTION																
	0730 006 994	A=2,00					1	1	1											
	0730 006 995	A=2,05					1	1	1											
	0730 006 996	A=2,10					1	1	1											
	0730 006 997	A=2,15					1	1	1											
	0730 006 998	A=2,20					1	1	1											
	0730 006 999	A=2,25					1	1	1											
	0730 007 001	A=2,30					1	1	1											
	0730 007 002	A=2,35					1	1	1											
	0730 007 003	A=2,40					1	1	1											
	0730 007 004	A=2,45					1	1	1											
	0730 007 005	A=2,50					1	1	1											
	0730 007 006	A=2,55					1	1	1											
	0730 007 007	A=2,60					1	1	1											
	0730 007 008	A=2,65					1	1	1											
	0730 007 009	A=2,70					1	1	1											
	0730 007 010	A=2,75					1	1	1											
	0730 007 011	A=2,80					1	1	1											
	0730 007 012	A=2,85					1	1	1											
300	0630 531 036 30X2 DIN 471	SICHERUNGSRING	RETAINING RING	JONC D'ARRET			1	1	1											
310	0630 362 040 34 DIN 470	VERSCHL.SCHEIBE	SEALING DISC	RONDELLE FERMET			1	1	1											

Gruppe 2094 122 PUMPENANTRIEB
 Group PUMP DRIVE
 Groupe ENTRAIN.POMPE

Stückzahl nach Ausführung / Quantity per model /
 Nombre par modèle

2094 001

19.05.93

Bild Nr. Fig. No. Fig. No.	Teilnummer Partnumber No. de pièce	Benennung	Description	Désignation	Änderung Modification Modification	alle all tous	Stückzahl nach Ausführung / Quantity per model / Nombre par modèle											
							019	020	021									
320	2094 336 015	FLANSCH	FLANGE	BRIDE			1	1	1									
330	0634 303 312 30 X 2,5 ZFN 744 NBR -70-10	O-RING	O-RING	JOINT TORIQUE			2	2	2									
340	2094 347 011	KRUEMMER	MANIFOLD	COUDE			1	1	1									
350	2094 322 018	DICHTUNG	GASKET	JOINT			2	2	2									
360	0636 015 084 M 8 X 22 DIN 933 8.8	6KT.SCHRAUBE	HEXAGON SCREW	VIS HEXAGONALE			4	4	4									
370	2094 347 012	KRUEMMER	MANIFOLD	COUDE			1	1	1									
380	0636 010 084 M 8 X 45 DIN 931 8.8	6KT.SCHRAUBE	HEXAGON SCREW	VIS HEXAGONALE			2	2	2									
390	0636 010 092 M 8 X 55 DIN 931 8.8	6KT.SCHRAUBE	HEXAGON SCREW	VIS HEXAGONALE			2	2	2									
400	2094 347 037	ROHR	PIPE	TUBE			1	1	1									
410	0634 306 214 23 X 2,5 ZFN 744 NBR -70-10	O-RING	O-RING	JOINT TORIQUE			2	2	2									
420	0630 505 521 A 28 DIN 7993	SPRENGRING	SNAP RING	CIRCLIP			2	2	2									
430	0501 208 802	SENSOR					1	1	1									
440	0501 208 803	SENSOR					1	1	1									

ZFP-075.00 02/92 30.000

Gruppe 2094 122 PUMPENANTRIEB
 Group PUMP DRIVE
 Groupe ENTRAIN.POMPE

Stückzahl nach Ausführung / Quantity per model /
 Nombre par modèle

2094 001

19.05.93

Bild Nr. Fig. No. Fig. No.	Teilnummer Partnumber No. de pièce	Benennung	Description	Désignation	Änderung Modification Modification	alle all tous	Stückzahl nach Ausführung / Quantity per model / Nombre par modèle													
							019	020	021											
450	0636 101 027 M 8 X 20 DIN 912 8.8	ZYL.SCHRAUBE	CAP SCREW	VIS TETE CYL.			2													
	0636 101 415 M 8 X 16 DIN 912 8.8	ZYL.SCHRAUBE	CAP SCREW	VIS TETE CYL.					2	2										
460	2094 322 041	DICHTUNG	GASKET	JOINT			1	1	1											
470	0631 306 076 10 M 6X 35 ZFN 6 ST50K * 9S20K	ZYLINDERSTIFT	CYLINDRICAL PIN	GOUPILLE CYL.			2	2	2											
480	0636 010 156 M 10 X 40 DIN 931 8.8	6KT.SCHRAUBE	HEXAGON SCREW	VIS HEXAGONALE			13	13	13											
	0636 010 174 M 10 X 60 DIN 931 8.8	6KT.SCHRAUBE	HEXAGON SCREW	VIS HEXAGONALE			3	3	3											
	0636 010 192 M 10 X 95 DIN 931 8.8	6KT.SCHRAUBE	HEXAGON SCREW	VIS HEXAGONALE			2	2	2											
	0636 010 200 M 10 X110 DIN 931 8.8	6KT.SCHRAUBE	HEXAGON SCREW	VIS HEXAGONALE			2	2	2											

ZFP-075.00 02/92 30.000

Gruppe 2094 136 OELVERSORGUNG
Group OIL SUPPLY
Groupe ALIMENT•HUILE

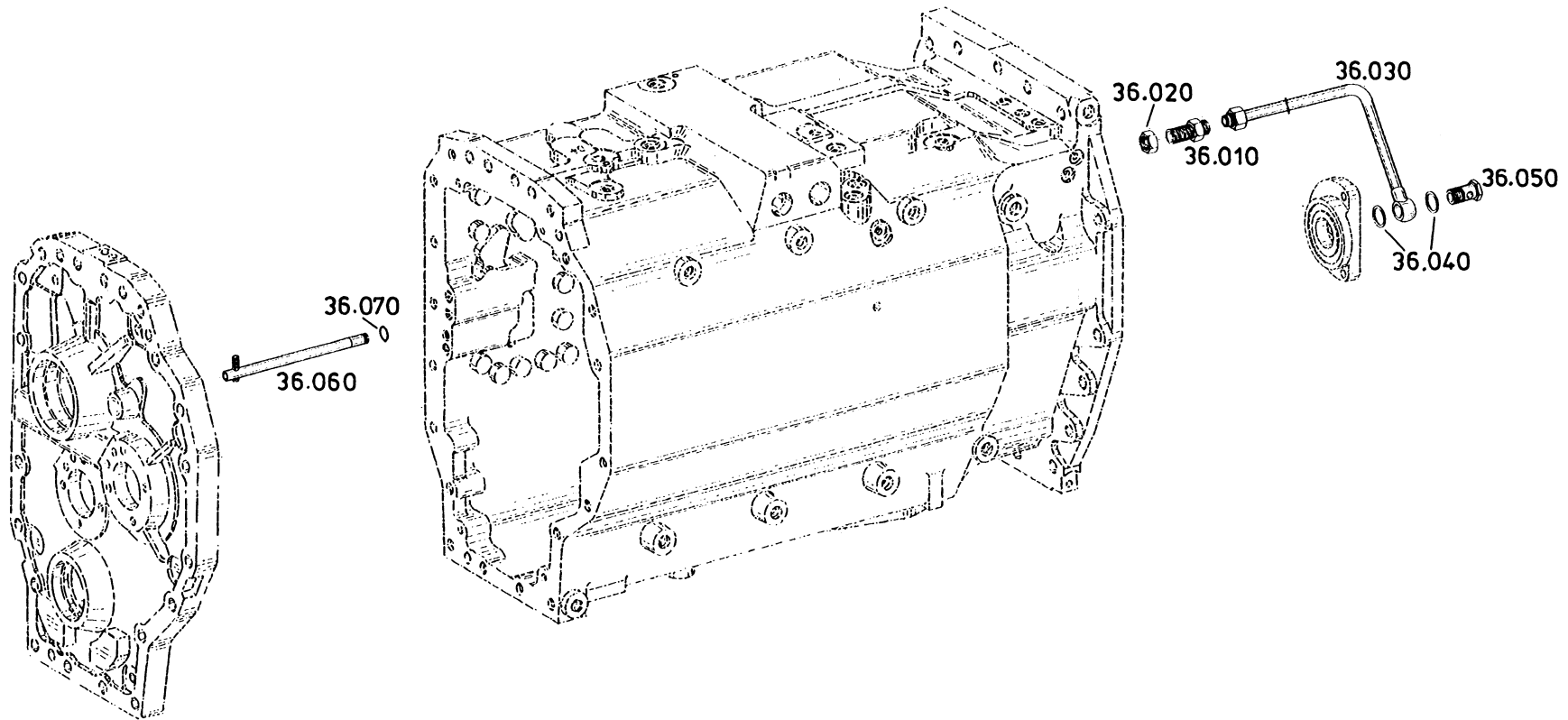

Die Abbildungen sind für die Ausführung nicht verbindlich
Illustrations are not binding for the design
Les illustrations ne sont pas obligatoires pour l'exécution

Gruppe 2094 136 DELVERSORGUNG
 Group OIL SUPPLY
 Groupe ALIMENT.HUILE

Stückzahl nach Ausführung / Quantity per model /
 Nombre par modèle

2094 001

19.05.93

Bild Nr. Fig. No. Fig. No.	Teilnummer Partnumber No. de pièce	Benennung	Description	Désignation	Änderung Modification Modification	Stückzahl nach Ausführung / Quantity per model / Nombre par modèle														
						alle all tous	019	020	021											
010	0637 846 604 L 18 DIN 3910 ST	SCHOTTSTUTZEN	NIPPLE	MANCHON			1	1	1											
020	0637 019 004 M 26X1,5 DIN 80705 ALT 5S FE/ZNPHR8F	MUTTER AUSG.6.69	NUT	ECROU			1	1	1											
030	2094 236 001	ROHR	PIPE	TUBE			1	1	1											
040	0634 801 073 A 22 X 27 DIN 7603 ST	DICHTRING	SEALING RING	BAGUE ETANCH.			2	2	2											
050	0637 835 006 18 DIN 7643	HOHLSCHRAUBE	UNION SCREW	VIS CREUSE			1	1	1											
060	2094 236 002	ROHR	PIPE	TUBE			1	1	1											
070	0634 306 186 12 X 1,5 ZFN 744 NBR -70-10	O-RING	O-RING	JOINT TORIQUE			1	1	1											

Gruppe 2094 147 DELVERSORGUNG
 Group OIL SUPPLY
 Groupe ALIMENT. HUILE

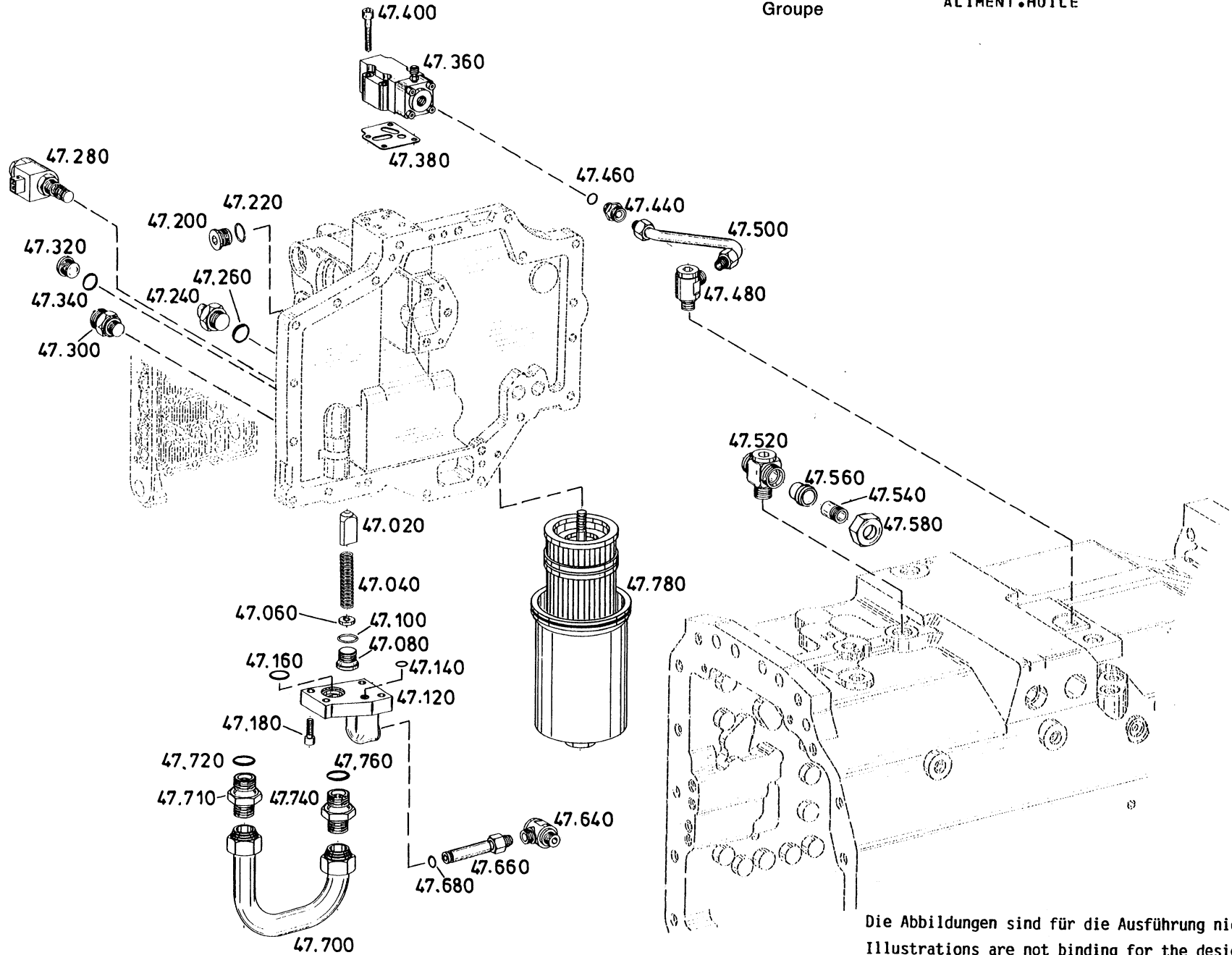

Die Abbildungen sind für die Ausführung nicht verbindlich
 Illustrations are not binding for the design
 Les illustrations ne sont pas obligatoires pour l'exécution

Gruppe 2094 147 DELVERSORGUNG
 Group OIL SUPPLY
 Groupe ALIMENT.HUILE

Stückzahl nach Ausführung / Quantity per model /
 Nombre par modèle

2094 001

19.05.93

Bild Nr. Fig. No. Fig. No.	Teilnummer Partnumber No. de pièce	Benennung	Description	Désignation	Änderung Modification Modification	alle all tous	Stückzahl nach Ausführung / Quantity per model / Nombre par modèle											
							019	020	021									
020	2094 336 030	VENTILKEGEL	VALVE CONE	CONE DE VALVE			1	1	1									
040	1405 301 021	DRUCKFEDER	COMPR.SPRING	RESSORT PRESS.			1	1	1									
060		ANLAUFSCHLEIBE WAHLWEISE	THRUST WASHER OPTIONAL	RONDELLE BUTEE EN OPTION														
	0770 032 662	S=3,25					1	1	1									
	0770 032 659	S=3,5					1	1	1									
	0770 032 663	S=3,75					1	1	1									
	0770 032 964	S=4,0					1	1	1									
	0770 032 965	S=4,25					1	1	1									
	0770 032 966	S=4,5					1	1	1									
	0770 032 967	S=4,75					1	1	1									
	0770 032 657	S=2,50					1	1	1									
	0770 032 661	S=2,75					1	1	1									
	0770 032 658	S=3,0					1	1	1									
080	0636 302 008 M 26X1,5 DIN 908 ST	VERSCHL.SCHR.	SCREW PLUG	VIS FERMETURE			1	1	1									
100	0634 303 233 23 X 2 ZFN 744 NBR -70-10	O-RING	O-RING	JOINT TORIQUE			1	1	1									
120	2094 347 031	FLANSCH	FLANGE	BRIDE			1	1	1									
140	0634 313 035 8 X 2,5 ZFN 744 FPM -70-10	O-RING	O-RING	JOINT TORIQUE			1	1	1									
160	0634 303 293 28 X 3 ZFN 744 NBR -70-10	O-RING	O-RING	JOINT TORIQUE			1	1	1									
180	0636 101 031 M 8 X 30 DIN 912 8.8	ZYL.SCHRAUBE	CAP SCREW	VIS TETE CYL.			4	4	4									

Gruppe 2094 147 DELVERSORGUNG
 Group OIL SUPPLY
 Groupe ALIMENT.HUILE

Stückzahl nach Ausführung / Quantity per model /
 Nombre par modèle

2094 001

19.05.93

Bild Nr. Fig. No. Fig. No.	Teilnummer Partnumber No. de pièce	Benennung	Description	Désignation	Änderung Modification Modification	alle all tous	Stückzahl nach Ausführung / Quantity per model / Nombre par modèle													
							019	020	021											
200	0636 302 015 M 22X1,5 DIN 908 ST	VERSCHL.SCHR.	SCREW PLUG	VIS FERMETURE			1	1	1											
220	0634 304 287 19 X 2 ZFN 744 NBR -70-10	O-RING	O-RING	JOINT TORIQUE			1	1	1											
240	0501 313 601	SCHALTER	SWITCH	INTERRUPTEUR			1	1	1											
260	0634 304 287 19 X 2 ZFN 744 NBR -70-10	O-RING	O-RING	JOINT TORIQUE			1	1	1											
280	0501 313 662	MAGNETVENTIL	SOLENOID VALVE	ELECTROVANNE			1	1	1											
300	0501 310 043	KONTR.SCHALTER	CONTROL SWITCH	CONTACTEUR TEM.			1	1	1											
320	0636 302 014 M 18X1,5 DIN 908 ST	VERSCHL.SCHR.	SCREW PLUG	VIS FERMETURE			1	1	1											
340	0634 306 524 15 X 2 ZFN 744 NBR -70-10	O-RING	O-RING	JOINT TORIQUE			1	1	1											
360	0501 004 722	VENTIL	VALVE	VALVE			1	1	1											
380	2094 347 027	DICHTUNG	GASKET	JOINT			1	1	1											
400	0636 101 036 M 8 X 50 DIN 912 8.8	ZYL.SCHRAUBE	CAP SCREW	VIS TETE CYL.			4	4	4											

Gruppe 2094 147 DELVERSORGUNG
 Group OIL SUPPLY
 Groupe ALIMENT.HUILE

Stückzahl nach Ausführung / Quantity per model /
 Nombre par modèle

2094 001

19.05.93

Bild Nr. Fig. No. Fig. No.	Teilnummer Partnumber No. de pièce	Benennung	Description	Désignation	Änderung Modification Modification	Stückzahl nach Ausführung / Quantity per model / Nombre par modèle														
						alle all tous	019	020	021											
440	0637 842 510 L 12 BM DIN 3901 ST	EINSCHR.STUTZEN	SCREW-IN SLEEVE	RACCORD FILETE			1	1	1											
460	0634 306 012 13,3 X 2,4 ZFN 744 NBR -70-10	O-RING	O-RING	JOINT TORIQUE			1	1	1											
480	0501 309 404	VERSCHRAUBUNG	PIPE UNION	RACCORD A VIS			1	1	1											
500	2094 247 013	ROHR	PIPE	TUBE			1	1	1											
520	0637 885 214 DSVT 22-LM OMD	VERSCHRAUBUNG	PIPE UNION	RACCORD A VIS			1	1	1											
540	0637 885 213 XKOR 22/15-PL	REDUZIERUNG	REDUCER	REDUCTION			1	1	1											
560	0637 880 035 L 22 DIN 3861 ST	SCHNEIDRING	CUTTING RING	BAGUE DE COUPE			1	1	1											
580	0637 880 047 AL 22 DIN 3870	UEBERWURFMUTTER	UNION NUT	ECROU - CHAPEAU			1	1	1											
640	0501 309 404	VERSCHRAUBUNG	PIPE UNION	RACCORD A VIS			1	1	1											
660	2094 247 015	ROHR	PIPE	TUBE			1	1	1											
680	0634 313 593 10 X 2,5 ZFN 744 FPM -80-10	O-RING	O-RING	JOINT TORIQUE			1	1	1											
700	2094 247 017	ROHR	PIPE	TUBE			1	1	1											
710	0737 843 077	EINSCHR.STUTZEN	SCREW-IN SLEEVE	RACCORD FILETE			1	1	1											

ZFP-075.00 02/92 30.000

Gruppe 2094 147 OELVERSORGUNG
 Group OIL SUPPLY
 Groupe ALIMENT.HUILE

Stückzahl nach Ausführung / Quantity per model /
 Nombre par modèle

2094 001

19.05.93

Bild Nr. Fig. No. Fig. No.	Teilnummer Partnumber No. de pièce	Benennung	Description	Désignation	Änderung Modification Modification	Stückzahl nach Ausführung / Quantity per model / Nombre par modèle														
						alle all tous	019	020	021											
720	0634 303 283 27 X 2,5 ZFN 744 NBR -70-10	O-RING	O-RING	JOINT TORIQUE			1	1	1											
740	0637 885 316 GE 28-LM-OMD	VERSCHRAUBUNG	PIPE UNION	RACCORD A VIS			1	1	1											
760	0634 306 047 30 X 3 ZFN 744 NBR -70-10	O-RING	O-RING	JOINT TORIQUE			1	1	1											
780	---	SAUGFILTER *	SUCTION FILTER *	FILTRE D'ASPIR. *			1	1	1											
		* SIEHE SEITE 77 * SEE PAGE 77 * VOYEZ PAGE 77																		

Gruppe 2094 192 SCHALTEILE
Group GEARSHIFT PARTS
Groupe ELTS PASS.VIT.

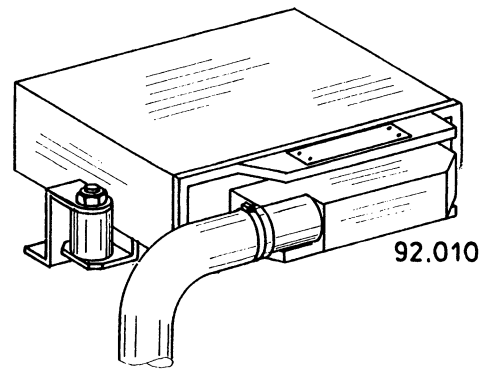

Die Abbildungen sind für die Ausführung nicht verbindlich
Illustrations are not binding for the design
Les illustrations ne sont pas obligatoires pour l'exécution

Gruppe 2094 192 SCHALTTEILE
 Group GEARSHIFT PARTS
 Groupe ELTS PASS.VIT.

Stückzahl nach Ausführung / Quantity per model /
 Nombre par modèle
 2094 001 19.05.93

Bild Nr. Fig. No. Fig. No.	Teilnummer Partnumber No. de pièce	Benennung	Description	Désignation	Änderung Modification Modification	Stückzahl nach Ausführung / Quantity per model / Nombre par modèle														
						alle all tous	019	020	021											
010	6009 059 010	STEUERUNG	CONTROL UNIT	COMMANDE			1													

Gruppe 0501 209 FILTER
Group FILTER
Groupe FILTRE

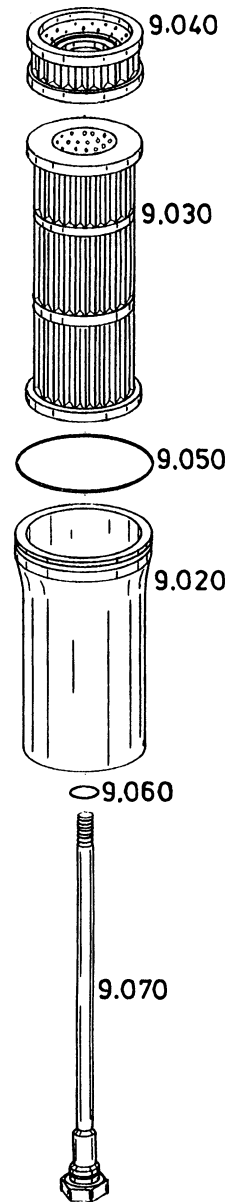

Die Abbildungen sind für die Ausführung nicht verbindlich
Illustrations are not binding for the design
Les illustrations ne sont pas obligatoires pour l'exécution

Gruppe 0501 209 FILTER
 Group FILTER
 Groupe FILTRE

Stückzahl nach Ausführung / Quantity per model /
 Nombre par modèle
 2094 001 19.05.93

Bild Nr. Fig. No. Fig. No.	Teilnummer Partnumber No. de pièce	Benennung	Description	Désignation	Änderung Modification Modification	Stückzahl nach Ausführung / Quantity per model / Nombre par modèle														
						alle all tous	019	020	021											
---	0501 209 080	FILTER KPL. BESTEHEND AUS: BILD NR. 020-070	FILTER CPL. CONSISTING OF: FIG NO. 020-070	FILTRE CPL. COMPOSE DE: FIG NO. 020-070			1	1	1											
020	0501 314 632	GEHAEUSE	HOUSING	CARTER			1	1	1											
030	0501 314 626	PAPIERFILTER	PAPERFILTER	FILTRE EN PAPIER			1	1	1											
040	0501 314 634	VENTILSCHUTZSIEB	SCREEN FILTER	FILTRE MICROMETIQUE			1	1	1											
050	0634 313 487 112x3 ZFN 744 FPM -70-10	O-RING	O-RING	JOINT TORIQUE			1	1	1											
060	0634 313 198 20x3 ZFN 744 FPM -70-10	O-RING	O-RING	JOINT TORIQUE			1	1	1											
070	0501 209 279	STAB KPL. MIT BILD NR. 060	BAR KPL. WITH FIG NO. 060	BARRE CPL. AVEC FIG NO. 060			1	1	1											

Gruppe 2094 199 LOSTEILE
Group LOOSE PARTS
Groupe PCES.DETACHEES

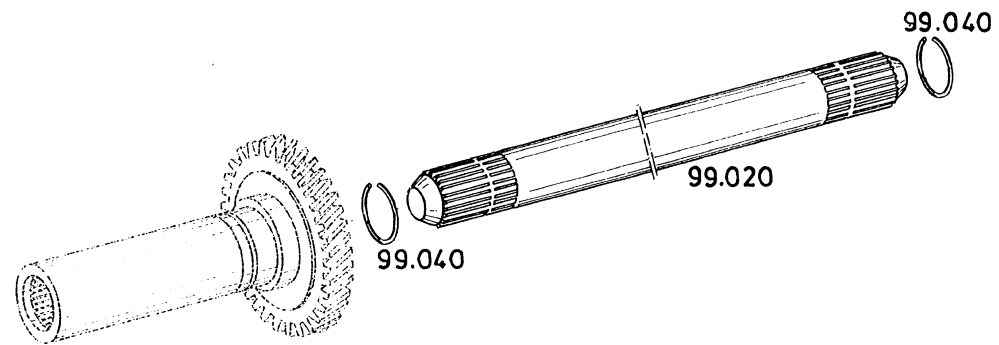

Die Abbildungen sind für die Ausführung nicht verbindlich
Illustrations are not binding for the design
Les illustrations ne sont pas obligatoires pour l'exécution

Gruppe 2094 199 LOSTEILE
 Group LOOSE PARTS
 Groupe PCES.DETACHEES

Stückzahl nach Ausführung / Quantity per model /
 Nombre par modèle

2094 001

19.05.93

Bild Nr. Fig. No. Fig. No.	Teilnummer Partnumber No. de pièce	Benennung	Description	Désignation	Änderung Modification Modification	Stückzahl nach Ausführung / Quantity per model / Nombre par modèle														
						alle all tous	019	020	021											
020	2094 310 005	WELLE	SHAFT	ARBRE			1	1	1											
040	0630 505 535 A 35 DIN 7993	SPRENGRING	SNAP RING	CIRCLIP			2	2	2											

ZFP-075.00 02/92 30.000

