

**ERSATZTEIL-LISTE
SPARE PARTS LIST
LISTE DES PIECES DE
RECHANCE**

Änderungen vorbehalten!
With the reserve of modifications
Modifications reserves!

**ZF-SCHLEPPERTRIEBWERK
ZF-TRACTOR TRANSMISSION
ENSEMBLE BOITE-PONT ZF
POUR TRACTEURS AGRICOLES**

Stückliste Nr.: / Parts list No.: / Liste de pieces No.: 2094 004 002/003/004/005/006/007



ZF Passau GmbH
Donaustr. 25-71 94034 Passau

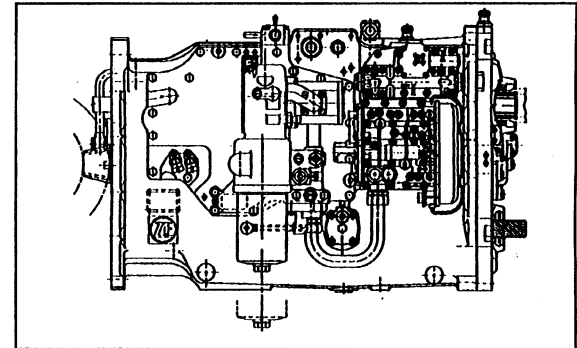

T-7300

Ausgabe: 11.94

LIEFERBEDINGUNGEN FÜR ERSATZTEILE

Bestellungen auf Ersatzteile sollen stets folgende Angaben enthalten, um eine richtige und schnelle Lieferung zu sichern:

1. **Type**
2. **Aggregatnummer**
3. **Stücklistennummer**
4. **Fabrikat und Typw des Fahrzeuges**
5. **Benennung des Ersatzteils:** Wie in der Ersatzteilliste aufgeführt.
6. **Ersatzteil-Nummer:** Siehe Ersatzteilliste, Nummer ist größtenteils auch imTeil eingeschlagen.
7. **Versandart:** Post, Luftpost, Express, Fracht, Eilgut, Stückgut; fehlen Angaben, so geschieht der Versand nach unserem Ermessen.

} Angaben siehe Typenschild
bzw. eingeschlagene Zahlen

Telefonische oder telegrafische Bestellungen bitten wir schriftlich zu bestätigen.

Der Versand geschieht auf Gefahr des Käufers, auch dann, wenn die Ersatzteile nicht berechnet werden.

Zahlungsbedingungen: Die Kosten für Ersatzteile werden durch Nachnahme erhoben.

DELIVERY CONDITIONS FOR SPARE PARTS

In order to secure a correct and prompt delivery, all spare part orders should be compiled as follows:

1. **Type**
2. **Serial-No.**
3. **Parts list No.**
4. **Trade mark and type of vehicle:**
5. **Denomination of spare part:** according to the indication in the parts list.
6. **Spare parts No.:** see spare parts list, the number is very often engraved on the part.
7. **Way of delivery:** mail, air mail, express delivery, ordinary freight, express goods, cargo; if no indication is made, the transportation will be realized to our opinion.

} see indications on type
identification plate
resp. engraved part number

We kindly ask you to confirm orders given by telephone call or telegramme.

Even if the spare parts are free of charge the delivery will be to the buyers obligation.

Terms: Cash on delivery.

CONDITIONS DE LIVRAISON POUR LES PIÈCES DE RECHANGE

Afin de vous assurer une prompte et correcte livraison, les commandes des pièces de rechange doivent être rédigées dans la façon suivante:

1. **Type**
2. **No. de la série**
3. **No. de la liste de pièces**
4. **Marque et type de véhicule**
5. **Dénomination de la pièce de rechange** come indiqué sur la liste des pièces de rechange.
6. **No. de la pièce:** v. liste des pièces de rechange, la plupart du temps, le nombre vient aussi poinçonné sur la pièce.
7. **Mode d'expédition:** ar poste, poste aérienne, express, en grande vitesse, en colis; où il n'y a pas des spécifications, l'expédition sera effectuée à notre choix.

} v. les indications sur la plaque
de type, resp. les chiffres poinçonnées

Nous vous prions de nous confirmer par écrit les commandes données par téléphone ou télégramme.

La marchandise sera toujours expédiée aux risques de l'acheteur, même dans le cas où les pièces de rechange ne viennent pas facturées.

Conditions de payment: contre remboursement.

INHALTSVERZEICHNIS	TABLE OF CONTENTS	TABLE DES MATIERES	GRUPPE GROUP GROUPE	SEITE PAGE PAGE
--------------------	-------------------	--------------------	---------------------------	-----------------------

BETR.BREMSE	SERVICE BRAKE	FREIN DE SERVICE	124	41
FAHRKUPPLUNG	DRIVE CLUTCH	EMBRAYAGE	113	19
FILTER	FILTER	FILTRE	209	79
GETRIEBEGEHAUSE	GEARBOX HOUSING	CARTER DE BOITE	101	23
HAUPTWELLE	MAIN SHAFT	ARBRE PRINCIPAL	104	33
HYDR.SCHALTUNG	GEARSH.SYST.HYDR.	CHANGEMT.VIT HYDR.	177	59
KRIECHGANG	CRAWLER	VIT.EXTRA-LENTE	114	27
LASTSCHALTGRUPPE	POWER SHIFT GROUP	CH. DE VIT.SOUS CHARGE	159	13
LOSTEILE	LOOSE PARTS	PCES.DETACHEES	199	77
OELVERSORGUNG	OIL SUPPLY	ALIMENT.HUILE	136	69
OELVERSORGUNG	OIL SUPPLY	ALIMENT.HUILE	147	71
PUMPENANTRIEB	PUMP DRIVE	ENTRAIN.POMPE	122	63
SCHALTUNG	GEARSHIFT SYST.	CHANGEMT. VIT.	106	45
SCHALTUNG	GEARSHIFT SYST.	CHANGEMT. VIT.	152	52
SPLITGRUPPE	SPLITTER GROUP	SPLITTER	168	3
VORDERRADANTRIEB	FRONT WH.DRIVE	ENTAIN.ROUE AV	146	37
VORGELEGEWELLE	LAYSHAFT	ARBRE INTERM.	103	29
ZAPFWELLE	P.T.O. SHAFT	PRISE DE FORCE	110	11

Gruppe 2094 168 SPLITGRUPPE
 Group
 Groupe

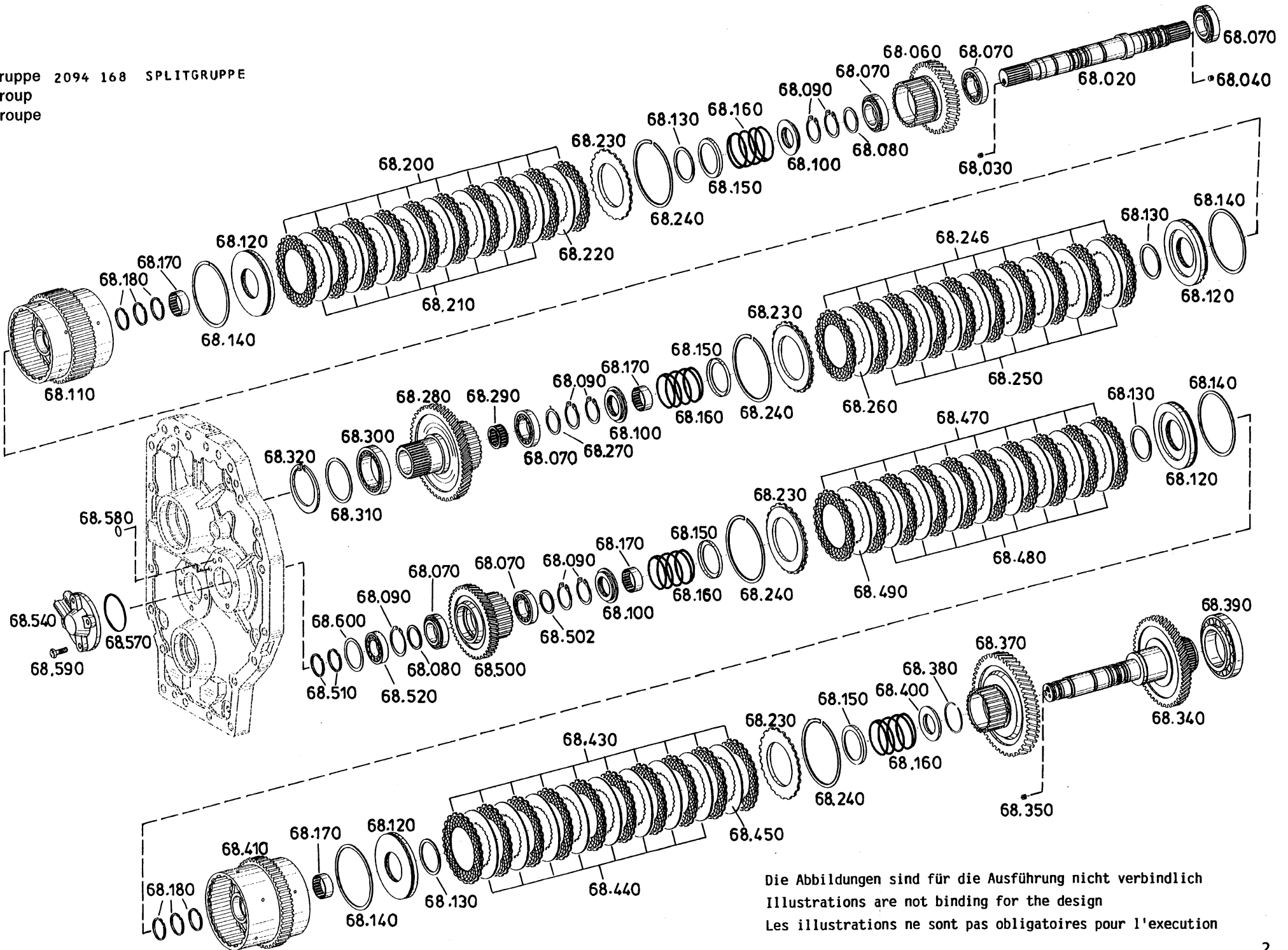

Die Abbildungen sind für die Ausführung nicht verbindlich
 Illustrations are not binding for the design
 Les illustrations ne sont pas obligatoires pour l'exécution

Gruppe 2094 168 SPLIT-GRUPPE
 Group POWERSH.SPLITT.
 Groupe DOUBL.DE GAMME

Stückzahl nach Ausführung / Quantity per model /
 Nombre par modèle

2094 004

11.11.94

Bild Nr. Fig. No. Fig. No.	Teilnummer Partnumber No. de pièce	Benennung	Description	Désignation	Änderung Modification Modification	2094 004							11.11.94					
						alle all tous	002	003	004	005	006	007						
020	2094 359 031	ANTRIEBSWELLE	INPUT SHAFT	ARBRE D'ENTREE			1	1										
	2094 359 041	ANTRIEBSWELLE	INPUT SHAFT	ARBRE D'ENTREE					1	1	1	1						
030	0731 607 026	BLENDE	ORIFICE	AJUTAGE			2	2	2	2	2	2						
040	0631 610 010 M 10 X 8 DIN 913 8.8	GEWINDESTIFT	SET SCREW	GOUJON FILETE			2	2	2	2	2	2						
060	2094 359 034	STIRNRAD	SPUR GEAR	PIGNON CYLINDR. Z=41			1	1	1	1	1	1						
070	0750 117 504	ROLLENLAGER	ROLLER BEARING	ROULEM.A ROUL.			6	6	6	6								
	0750 117 656	ROLLENLAGER	ROLLER BEARING	ROULEM.A ROUL.								6	6					
080		AUSGL.SCHEIBE WAHLWEISE	SHIM OPTIONAL	RONDELLE EN OPTION														
	0730 107 830	S=1,45					2	2	2	2	2	2	2					
	0730 107 831	S=1,5					2	2	2	2	2	2	2					
	0730 107 832	S=1,55					2	2	2	2	2	2	2					
	0730 107 833	S=1,6					2	2	2	2	2	2	2					
	0730 107 834	S=1,65					2	2	2	2	2	2	2					
	0730 107 835	S=1,7					2	2	2	2	2	2	2					
	0730 107 836	S=1,75					2	2	2	2	2	2	2					
	0730 107 837	S=1,8					2	2	2	2	2	2	2					
	0730 109 572	S=1,475					2	2	2	2	2	2	2					
	0730 109 573	S=1,525					2	2	2	2	2	2	2					
	0730 109 574	S=1,575					2	2	2	2	2	2	2					
	0730 109 575	S=1,625					2	2	2	2	2	2	2					
	0730 109 576	S=1,675					2	2	2	2	2	2	2					
	0730 109 577	S=1,725					2	2	2	2	2	2	2					
	0730 109 578	S=1,775					2	2	2	2	2	2	2					
	0730 109 579	S=1,825					2	2	2	2	2	2	2					
	0730 109 580	S=1,85					2	2	2	2	2	2	2					
090	0501 314 965	SICHERUNGSRING	RETAINING RING	JONC D'ARRET					7	7	7	7						
	0630 531 050 40X2,5 DIN 471	SICHERUNGSRING	RETAINING RING	JONC D'ARRET			7	7										

Gruppe 2094 168 SPLIT-GRUPPE
 Group POWERSH.SPLITT.
 Groupe DOUBL.DE GAMME

Stückzahl nach Ausführung / Quantity per model /
 Nombre par modèle

2094 004

11.11.94

Bild Nr. Fig. No. Fig. No.	Teilnummer Partnumber No. de pièce	Benennung	Description	Désignation	Änderung Modification Modification	2094 004							11.11.94		
						alle all tous	002	003	004	005	006	007			
100	0735 298 130	NADELLAGER	NEEDLE BEARING	ROULEMT A AIG.			3	3	3	3	3	3			
110	2094 259 019	LAMELLENTRAEGER	DISC CARRIER	PORTE DISQUES			1	1	1	1	1	1			
120	2094 359 004	KOLBEN	PISTON	PISTON			4	4	4	4	4	4			
130	0750 112 140	PROFILDICHTRING	PROF.SEAL RING	JOINT PROFILE			4	4	4	4	4	4			
140	0750 112 141	PROFILDICHTRING	PROF.SEAL RING	JOINT PROFILE			4	4	4	4	4	4			
150	4642 308 083	FUEHRUNGSRING	GUIDE RING	BAGUE GUIDAGE			4	4	4	4	4	4			
160	0732 041 183	DRUCKFEDER	COMPR.SPRING	RESSORT PRESS.			4	4	4	4	4	4			
170	0750 115 365	NADELHUELSE	NEEDLE SLEEVE	DOUILLE A AIG.			4	4	4	4	4	4			
180	0634 402 541 40 X 2 DIN 34118	R-RING SH P KA	PISTON RING	SEGMENT			10	10	10	10	10	10			
200	0501 313 598	AUSSENLAMELLE	O.CLUTCH DISC	DISQUE EXT.			10	10	10	10	10	10			
210	2094 313 073	INNENLAMELLE	I.CLUTCH DISC	DISQUE INT.			8	8	8	8	8	8			
220		INNENLAMELLE WAHLWEISE	I.CLUTCH DISC OPTIONAL	DISQUE INT. EN OPTION											
	2094 313 071	S=1,5					1	1	1	1	1	1			
	2094 313 072	S=2,5					1	1	1	1	1	1			
	2094 313 073	S=2,0					1	1	1	1	1	1			
230	4642 308 185	ENDSCHEIBE	END SHIM	RONDELLE			4	4	4	4	4	4			
240	0730 513 180	SPRENGRING	SNAP RING	CIRCLIP			4	4	4	4	4	4			
246	0501 313 598	AUSSENLAMELLE	O.CLUTCH DISC	DISQUE EXT.			10	10	10	10	10	10			
250	2094 313 073	INNENLAMELLE	I.CLUTCH DISC	DISQUE INT.			8	8	8	8	8	8			
260		INNENLAMELLE WAHLWEISE	I.CLUTCH DISC OPTIONAL	DISQUE INT. EN OPTION											
	2094 313 071	S=1,5					1	1	1	1	1	1			
	2094 313 072	S=2,5					1	1	1	1	1	1			
	2094 313 073	S=2,0					1	1	1	1	1	1			
270	0730 107 826	AUSGL.SCHEIBE	SHIM	RONDELLE			1	1							

Gruppe 2094 168 SPLIT-GRUPPE
 Group POWERSH.SPLITT.
 Groupe DOUBL.DE GAMME

Stückzahl nach Ausführung / Quantity per model /
 Nombre par modèle

2094 004

11.11.94

Bild Nr. Fig. No. Fig. No.	Teilnummer Partnumber No. de pièce	Benennung	Description	Désignation	Änderung Modification Modification	2094 004							11.11.94		
						alle all tous	002	003	004	005	006	007			
	0730 107 831	AUSGL.SCHEIBE	SHIM	RONDELLE					1	1	1	1			
280	2094 359 030 Z=59	ANTRIEBSRAD	INPUT GEAR	ROUE MOTRICE			1	1							
	2094 359 039 Z=59	ANTRIEBSRAD	INPUT GEAR	ROUE MOTRICE					1	1	1	1			
290	0750 115 361	NADELKRANZ	NEEDLE CAGE	CAGE A AIG.			1	1	1	1	1	1			
300	0750 117 505	ROLLENLAGER	ROLLER BEARING	ROULEM.A ROUL.			1	1	1	1	1	1			
310		AUSGL.SCHEIBE WAHLWEISE	SHIM OPTIONAL	RONDELLE EN OPTION											
	0730 107 839	S=1,2					1	1	1	1	1	1			
	0730 107 840	S=1,25					1	1	1	1	1	1			
	0730 107 841	S=1,3					1	1	1	1	1	1			
	0730 107 842	S=1,35					1	1	1	1	1	1			
	0730 107 843	S=1,4					1	1	1	1	1	1			
	0730 107 844	S=1,45					1	1	1	1	1	1			
	0730 107 845	S=1,5					1	1	1	1	1	1			
	0730 107 846	S=1,55					1	1	1	1	1	1			
	0730 107 847	S=1,6					1	1	1	1	1	1			
	0730 107 848	S=1,65					1	1	1	1	1	1			
	0730 107 849	S=1,7					1	1	1	1	1	1			
	0730 107 850	S=1,75					1	1	1	1	1	1			
	0730 107 851	S=1,8					1	1	1	1	1	1			
	0730 107 852	S=1,85					1	1	1	1	1	1			
	0730 107 853	S=1,9					1	1	1	1	1	1			
	0730 107 854	S=1,95					1	1	1	1	1	1			
	0730 107 855	S=2,0					1	1	1	1	1	1			
	0730 107 856	S=2,05					1	1	1	1	1	1			
	0730 107 857	S=2,1					1	1	1	1	1	1			
	0730 107 858	S=2,15					1	1	1	1	1	1			
	0730 107 859	S=2,2					1	1	1	1	1	1			
320	0630 502 043 95X3 DIN 472	SICHERUNGSRING	RETAINING RING	JONC D'ARRET			1	1	1	1	1	1			
340	2094 359 037 Z=59	ABTRIEBSWELLE	OUTPUT SHAFT	ARBRE DE SORTIE			1	1	1	1	1	1			
350	0631 610 010 M 10 X 8 DIN 913 8.8	GEWINDESTIFT	SET SCREW	GOUJON FILETE			2	2	2	2	2	2			

Gruppe 2094 168 SPLIT-GRUPPE
 Group POWERSH.SPLITT.
 Groupe DOUBL.DE GAMME

Stückzahl nach Ausführung / Quantity per model /
 Nombre par modèle

2094 004

11.11.94

Bild Nr. Fig. No. Fig. No.	Teilnummer Partnumber No. de pièce	Benennung	Description	Désignation	Änderung Modification Modification	alle all tous									
						002	003	004	005	006	007				
370	2094 359 032 Z=60	STIRNRAD	SPUR GEAR	PIGNON CYLINDR.			1	1	1	1	1	1			
380	0630 513 093 SW 65	SPRENGRING	SNAP RING	CIRCLIP			1	1	1	1	1	1			
390	0750 117 267	ROLLENLAGER	ROLLER BEARING	ROULEM.A ROUL.			1	1	1	1	1	1			
400	0735 298 131	NADELLAGER	NEEDLE BEARING	ROULEMT A AIG.			1	1	1	1	1	1			
410	2094 259 020	LAMELLENTRAEGER	DISC CARRIER	PORTE DISQUES			1	1	1	1	1	1			
430	0501 313 598	AUSSENLAMELLE	O.CLUTCH DISC	DISQUE EXT.			10	10	10	10	10	10			
440	2094 313 073	INNENLAMELLE	I.CLUTCH DISC	DISQUE INT.			8	8	8	8	8	8			
450		INNENLAMELLE WAHLWEISE	I.CLUTCH DISC OPTIONAL	DISQUE INT. EN OPTION											
	2094 313 071	S=1,5					1	1	1	1	1	1			
	2094 313 072	S=2,5					1	1	1	1	1	1			
	2094 313 073	S=2,0					1	1	1	1	1	1			
470	0501 313 598	AUSSENLAMELLE	O.CLUTCH DISC	DISQUE EXT.			10	10	10	10	10	10			
480	2094 313 073	INNENLAMELLE	I.CLUTCH DISC	DISQUE INT.			8	8	8	8	8	8			
490		INNENLAMELLE WAHLWEISE	I.CLUTCH DISC OPTIONAL	DISQUE INT. EN OPTION											
	2094 313 071	S=1,5					1	1	1	1	1	1			
	2094 313 072	S=2,5					1	1	1	1	1	1			
	2094 313 073	S=2,0					1	1	1	1	1	1			
500	2094 359 033 Z=50	STIRNRAD	SPUR GEAR	PIGNON CYLINDR.			1	1							
	2094 359 040 Z=50 RE	STIRNRAD	SPUR GEAR	PIGNON CYLINDR.					1	1	1	1			
502	0730 107 831	AUSGL.SCHEIBE	SHIM	RONDELLE					1	1	1	1			
510	0634 402 540 35 X 2 DIN 34118	R-RING SH P KA	PISTON RING	SEGMENT			2	2	2	2	2	2			
520	0750 117 503	ROLLENLAGER	ROLLER BEARING	ROULEM.A ROUL.			1	1	1	1	1	1			

Gruppe 2094 168 SPLIT-GRUPPE
 Group POWERSH.SPLITT.
 Groupe DOUBL.DE GAMME

Stückzahl nach Ausführung / Quantity per model /
 Nombre par modèle

2094 004

11.11.94

Bild Nr. Fig. No. Fig. No.	Teilnummer Partnumber No. de pièce	Benennung	Description	Désignation	Änderung Modification Modification	2094 004							11.11.94					
						alle all tous	002	003	004	005	006	007						
540	2094 259 007 KPL.	DECKEL	COVER	COUVERCLE			1	1										
	2094 259 007 KPL.	DECKEL	COVER	COUVERCLE					1	1	1	1						
570	0634 303 303 62 X 4 ZFN 744 NBR -70-10	O-RING	O-RING	JOINT TORIQUE			1	1	1	1	1	1						
580	0634 303 085 12 X 3 ZFN 744 NBR -70-10	O-RING	O-RING	JOINT TORIQUE			2	2	2	2	2	2						
590	0636 015 129 M 10 X 35 DIN 933 8.8	6KT.SCHRAUBE	HEXAGON SCREW	VIS HEXAGONALE			4	4	4	4	4	4						
600		AUSGL.SCHEIBE WAHLWEISE	SHIM OPTIONAL	RONDELLE EN OPTION														
	0730 101 078	S=1,3					1	1	1	1	1	1						
	0730 101 077	S=1,5					1	1	1	1	1	1						
	0730 101 076	S=1,7					1	1	1	1	1	1						
	0730 101 075	S=1,9					1	1	1	1	1	1						
	0730 101 074	S=2,1					1	1	1	1	1	1						
	0730 101 073	S=2,3					1	1	1	1	1	1						
	0730 106 657	S=1,2					1	1	1	1	1	1						
	0730 106 658	S=1,25					1	1	1	1	1	1						
	0730 106 659	S=1,35					1	1	1	1	1	1						
	0730 103 474	S=1,4					1	1	1	1	1	1						
	0730 106 660	S=1,45					1	1	1	1	1	1						
	0730 106 661	S=1,55					1	1	1	1	1	1						
	0730 103 473	S=1,6					1	1	1	1	1	1						
	0730 106 662	S=1,65					1	1	1	1	1	1						
	0730 106 663	S=1,75					1	1	1	1	1	1						
	0730 101 461	S=1,8					1	1	1	1	1	1						

Gruppe 2094 168 SPLIT-GRUPPE
 Group POWERSH.SPLITT.
 Groupe DOUBL.DE GAMME

Stückzahl nach Ausführung / Quantity per model /
 Nombre par modèle

2094 004

11.11.94

Bild Nr. Fig. No. Fig. No.	Teilnummer Partnumber No. de pièce	Benennung	Description	Désignation	Änderung Modification Modification	Stückzahl nach Ausführung / Quantity per model / Nombre par modèle									
						alle all tous	002	003	004	005	006	007			
	0730 107 518	S=1,85					1	1	1	1	1	1			
	0730 107 519	S=1,95					1	1	1	1	1	1			
	0730 101 462	S=2,0					1	1	1	1	1	1			
	0730 107 520	S=2,05					1	1	1	1	1	1			
	0730 107 521	S=2,15					1	1	1	1	1	1			
	0730 103 010	S=2,2					1	1	1	1	1	1			
	0730 107 522	S=2,25					1	1	1	1	1	1			
	0730 109 610	S=2,35					1	1	1	1	1	1			
	0730 109 611	S=2,40					1	1	1	1	1	1			
	0730 109 612	S=2,45					1	1	1	1	1	1			
	0730 109 613	S=2,50					1	1	1	1	1	1			

Gruppe 2094 110 ZAPFWELLE
Group P.T.O. SHAFT
Groupe PRISE DE FORCE

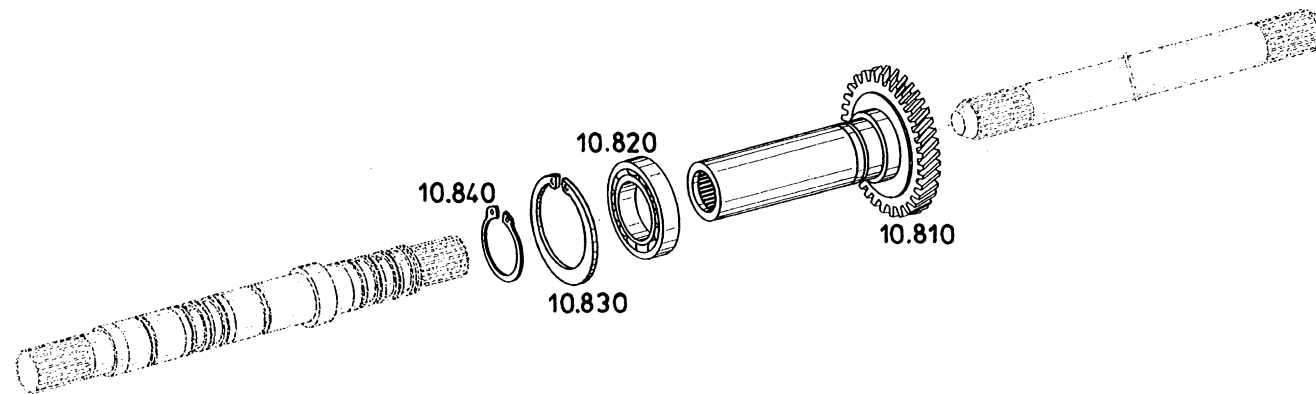

Die Abbildungen sind für die Ausführung nicht verbindlich
Illustrations are not binding for the design
Les illustrations ne sont pas obligatoires pour l'exécution

Gruppe 2094 110 ZAPFWELLE
 Group P.T.O.SHAFT
 Groupe PRISE DE FORCE

Stückzahl nach Ausführung / Quantity per model /
 Nombre par modèle

2094 004

11.11.94

Bild Nr. Fig. No. Fig. No.	Teilnummer Partnumber No. de pièce	Benennung	Description	Désignation	Änderung Modification Modification	alle all tous									
						002	003	004	005	006	007				
810	2094 310 054 Z=46	STIRNRAD	SPUR GEAR	PIGNON CYLINDR.			1	1	1	1	1	1			
820	0635 331 223	KUGELLAGER	BALL BEARING	ROULEM.A BILLES			1	1	1	1	1	1			
830	0630 502 039 80X2,5 DIN 472	SICHERUNGSRING	RETAINING RING	JONC D'ARRET			1	1	1	1	1	1			
840	0630 531 065 50X3 DIN 471	SICHERUNGSRING	RETAINING RING	JONC D'ARRET			1	1	1	1	1	1			

Gruppe 2094 159 LASTSCHALTGR.
Group
Groupe

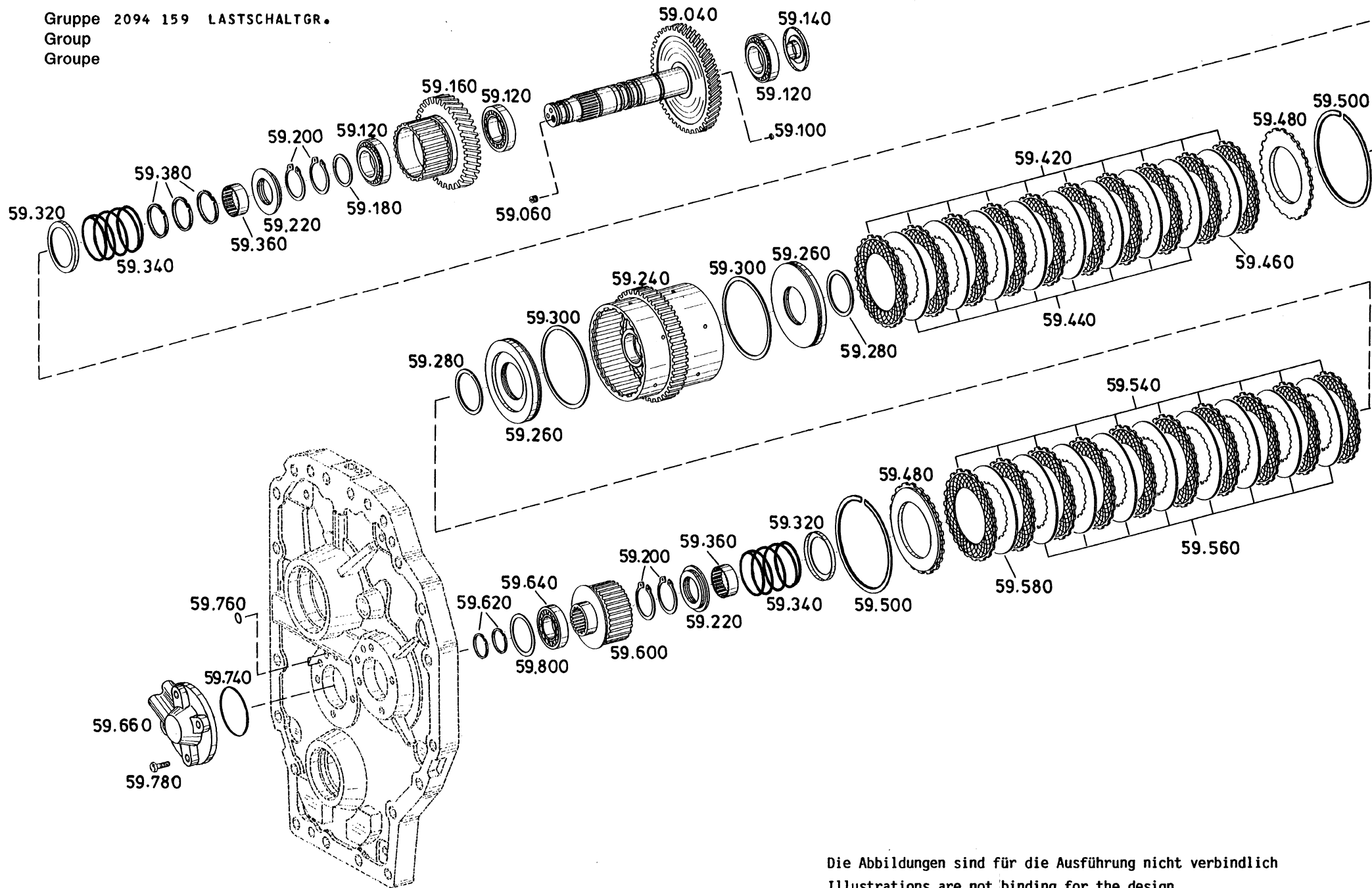

Die Abbildungen sind für die Ausführung nicht verbindlich
Illustrations are not binding for the design
Les illustrations ne sont pas obligatoires pour l'exécution

Bild Nr. Fig. No. Fig. No.	Teilnummer Partnumber No. de pièce	Benennung	Description	Désignation	Änderung Modification Modification	2094 004							11.11.94		
						alle all tous	002	003	004	005	006	007			
040	2094 359 042 Z=58	ZWISCHENWELLE	INTERM.SHAFT	ARBRE INTERM.			1	1	1	1	1	1			
060	0631 610 010 M 10 X 8 DIN 913 8.8	GEWINDESTIFT	SET SCREW	GOUJON FILETE			2	2	2	2	2	2			
100	0730 361 115	VERSCHL.DECKEL	SEALING CAP	COUVERCLE			1	1	1	1	1	1			
120	0750 117 504	ROLLENLAGER	ROLLER BEARING	ROULEM.A ROUL.			3	3	3	3					
	0750 117 656	ROLLENLAGER	ROLLER BEARING	ROULEM.A ROUL.								3	3		
140	2094 359 014	OELFANGBLECH	OIL COLL.PLATE	TOLE D'HUILE			1	1	1	1	1	1			
160	2094 359 034 Z=41	STIRNRAD	SPUR GEAR	PIGNON CYLINDR.			1	1	1	1	1	1			
180		AUSGL.SCHEIBE WAHLWEISE	SHIM OPTIONAL	RONDELLE EN OPTION											
	0730 107 830	S=1,45					1	1	1	1	1	1			
	0730 107 831	S=1,5					1	1	1	1	1	1			
	0730 107 832	S=1,55					1	1	1	1	1	1			
	0730 107 833	S=1,6					1	1	1	1	1	1			
	0730 107 834	S=1,65					1	1	1	1	1	1			
	0730 107 835	S=1,7					1	1	1	1	1	1			
	0730 107 836	S=1,75					1	1	1	1	1	1			
	0730 107 837	S=1,8					1	1	1	1	1	1			
	0730 109 572	S=1,475					1	1	1	1	1	1			
	0730 109 573	S=1,525					1	1	1	1	1	1			
	0730 109 574	S=1,575					1	1	1	1	1	1			
	0730 109 575	S=1,625					1	1	1	1	1	1			
	0730 109 576	S=1,675					1	1	1	1	1	1			
	0730 109 577	S=1,725					1	1	1	1	1	1			
	0730 109 578	S=1,775					1	1	1	1	1	1			
	0730 109 579	S=1,825					1	1	1	1	1	1			
	0730 109 580	S=1,85					1	1	1	1	1	1			
200	0501 314 965	SICHERUNGSRING	RETAINING RING	JONC D'ARRET			4	4	4	4	4	4			
220	0735 298 130	NADELLAGER	NEEDLE BEARING	ROULEMT A AIG.			2	2	2	2	2	2			
240	2094 259 020	LAMELLENTRAEGER	DISC CARRIER	PORTE DISQUES			1	1	1	1	1	1			
260	2094 359 004	KOLBEN	PISTON	PISTON			2	2	2	2	2	2			

Gruppe 2094 159 LASTSCHALTGR.
 Group
 Groupe

Stückzahl nach Ausführung / Quantity per model /
 Nombre par modèle

2094 004

11.11.94

Bild Nr. Fig. No. Fig. No.	Teilnummer Partnumber No. de pièce	Benennung	Description	Désignation	Änderung Modification Modification	2094 004							11.11.94		
						alle all tous	002	003	004	005	006	007			
280	0750 112 140	PROFILDICHTRING	PROF.SEAL RING	JOINT PROFILE			2	2	2	2	2	2			
300	0750 112 141	PROFILDICHTRING	PROF.SEAL RING	JOINT PROFILE			2	2	2	2	2	2			
320	4642 308 083	FUEHRUNGSRING	GUIDE RING	BAGUE GUIDAGE			2	2	2	2	2	2			
340	0732 041 183	DRUCKFEDER	COMPR.SPRING	RESSORT PRESS.			2	2	2	2	2	2			
360	0750 115 365	NADELHUELSE	NEEDLE SLEEVE	DOUILLE A AIG.			2	2	2	2	2	2			
380	0634 402 541 40 X 2 DIN 34118	R-RING SH P KA	PISTON RING	SEGMENT			3	3	3	3	3	3			
420	0501 313 598	AUSSENLAMELLE	O.CLUTCH DISC	DISQUE EXT.			10	10	10	10	10	10			
440	2094 313 073	INNENLAMELLE	I.CLUTCH DISC	DISQUE INT.			8	8	8	8	8	8			
460		INNENLAMELLE WAHLWEISE	I.CLUTCH DISC OPTIONAL	DISQUE INT. EN OPTION											
	2094 313 071	S=1,5					1	1	1	1	1	1			
	2094 313 072	S=2,5					1	1	1	1	1	1			
	2094 313 073	S=2,0					1	1	1	1	1	1			
480	4642 308 185	ENDSCHEIBE	END SHIM	RONDELLE			2	2	2	2	2	2			
500	0730 513 180	SPRENGRING	SNAP RING	CIRCLIP			2	2	2	2	2	2			
540	0501 313 598	AUSSENLAMELLE	O.CLUTCH DISC	DISQUE EXT.			10	10	10	10	10	10			
560	2094 313 073	INNENLAMELLE	I.CLUTCH DISC	DISQUE INT.			8	8	8	8	8	8			
580		INNENLAMELLE WAHLWEISE	I.CLUTCH DISC OPTIONAL	DISQUE INT. EN OPTION											
	2094 313 071	S=1,5					1	1	1	1	1	1			
	2094 313 072	S=2,5					1	1	1	1	1	1			
	2094 313 073	S=2,0					1	1	1	1	1	1			
600	2094 359 011	INNENL.TRAEGER	I.DISC CARRIER	PORTE-DISQ.INT.			1	1	1	1	1	1			
620	0634 402 540 35 X 2 DIN 34118	R-RING SH P KA	PISTON RING	SEGMENT			2	2	2	2	2	2			

Gruppe 2094 159 LASTSCHALTGR.
 Group
 Groupe

Stückzahl nach Ausführung / Quantity per model /
 Nombre par modèle

2094 004

11.11.94

Bild Nr. Fig. No. Fig. No.	Teilnummer Partnumber No. de pièce	Benennung	Description	Désignation	Änderung Modification Modification	alle all tous	2094 004								
							002	003	004	005	006	007			
640	0750 117 503	ROLLENLAGER	ROLLER BEARING	ROULEM.A ROUL.			1	1	1	1	1	1			
660	2094 259 007	DECKEL	COVER	COUVERCLE			1	1	1	1	1	1			
740	0634 303 303 62 X 4 ZFN 744 NBR -70-10	O-RING	O-RING	JOINT TORIQUE			1	1	1	1	1	1			
760	0634 303 085 12 X 3 ZFN 744 NBR -70-10	O-RING	O-RING	JOINT TORIQUE			2	2	2	2	2	2			
780	0636 015 129 M 10 X 35 DIN 933 8.8	6KT.SCHRAUBE	HEXAGON SCREW	VIS HEXAGONALE			4	4	4	4	4	4			
800		AUSGL.SCHEIBE WAHLWEISE	SHIM OPTIONAL	RONDELLE EN OPTION											
	0730 101 078	S=1,3					1	1	1	1	1	1			
	0730 101 077	S=1,5					1	1	1	1	1	1			
	0730 101 076	S=1,7					1	1	1	1	1	1			
	0730 101 075	S=1,9					1	1	1	1	1	1			
	0730 101 074	S=2,1					1	1	1	1	1	1			
	0730 101 073	S=2,3					1	1	1	1	1	1			
	0730 106 657	S=1,2					1	1	1	1	1	1			
	0730 106 658	S=1,25					1	1	1	1	1	1			
	0730 106 659	S=1,35					1	1	1	1	1	1			
	0730 103 474	S=1,4					1	1	1	1	1	1			
	0730 106 660	S=1,45					1	1	1	1	1	1			
	0730 106 661	S=1,55					1	1	1	1	1	1			
	0730 103 473	S=1,6					1	1	1	1	1	1			
	0730 106 662	S=1,65					1	1	1	1	1	1			
	0730 106 663	S=1,75					1	1	1	1	1	1			
	0730 101 461	S=1,8					1	1	1	1	1	1			
	0730 107 518	S=1,85					1	1	1	1	1	1			
	0730 107 519	S=1,95					1	1	1	1	1	1			
	0730 101 462	S=2,0					1	1	1	1	1	1			
	0730 107 520	S=2,05					1	1	1	1	1	1			
	0730 107 521	S=2,15					1	1	1	1	1	1			
	0730 103 010	S=2,2					1	1	1	1	1	1			
	0730 107 522	S=2,25					1	1	1	1	1	1			

Gruppe 2094 159 LASTSCHALTGR.

Group

Groupe

Stückzahl nach Ausführung / Quantity per model /
Nombre par modèle

2094 004

11.11.94

Bild Nr. Fig. No. Fig. No.	Teilnummer Partnumber No. de pièce	Benennung	Description	Désignation	Änderung Modification Modification	alle all tous									
							002	003	004	005	006	007			
	0730 109 610	S=2,35					1	1	1	1	1	1			
	0730 109 611	S=2,40					1	1	1	1	1	1			
	0730 109 612	S=2,45					1	1	1	1	1	1			
	0730 109 613	S=2,50					1	1	1	1	1	1			

Gruppe 2094 113 FAHRKUPPLUNG
 Group DRIVE CLUTCH
 Groupe EMBRAYAGE

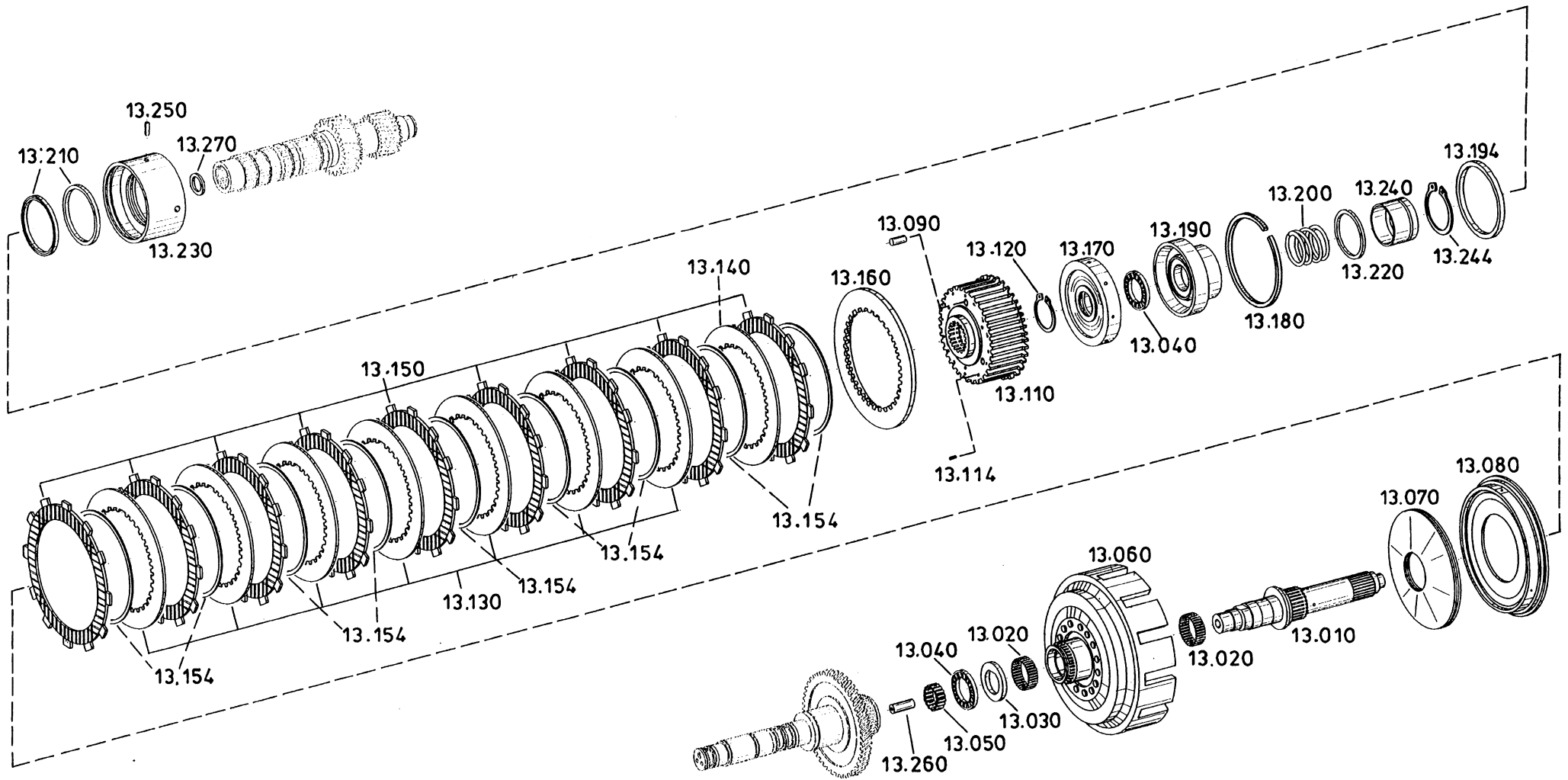

Die Abbildungen sind für die Ausführung nicht verbindlich
 Illustrations are not binding for the design
 Les illustrations ne sont pas obligatoires pour l'exécution

Bild Nr. Fig. No. Fig. No.	Teilnummer Partnumber No. de pièce	Benennung	Description	Désignation	Änderung Modification Modification	alle all tous	2094 004						11.11.94				
							002	003	004	005	006	007					
010	2094 313 062	KUPPLUNGSWELLE	CLUTCH SHAFT	ARBRE D'EMBR.			1										
	2094 313 068	KUPPLUNGSWELLE	CLUTCH SHAFT	ARBRE D'EMBR.				1	1	1	1	1	1				
020	0750 115 360	NADELKRANZ	NEEDLE CAGE	CAGE A AIG.			2	2	2	2	2	2					
030		SCHEIBE WAHLWEISE	WASHER OPTIONAL	RONDELLE EN OPTION													
	0730 109 606	A=6,65					1	1	1	1	1	1	1				
	0730 109 607	A=6,75					1	1	1	1	1	1	1				
	0730 109 608	A=6,85					1	1	1	1	1	1	1				
	0730 108 659	A=6,3					1	1	1	1	1	1	1				
	0730 108 660	A=6,4					1	1	1	1	1	1	1				
	0730 108 661	A=6,5					1	1	1	1	1	1	1				
	0730 108 662	A=6,6					1	1	1	1	1	1	1				
	0730 108 663	A=6,7					1	1	1	1	1	1	1				
	0730 108 664	A=6,8					1	1	1	1	1	1	1				
	0730 108 665	A=6,9					1	1	1	1	1	1	1				
	0730 108 666	A=7,0					1	1	1	1	1	1	1				
	0730 108 667	A=7,1					1	1	1	1	1	1	1				
	0730 108 668	A=7,2					1	1	1	1	1	1	1				
	0730 108 669	A=7,3					1	1	1	1	1	1	1				
	0730 108 670	A=7,4					1	1	1	1	1	1	1				
	0730 109 609	A=6,95					1	1	1	1	1	1	1				
040	0750 115 358	AX.ROLLENLAGER	AX.ROLLER BEAR.	BUTEE AX.ROULX.			2	2	2	2	2	2					
050	0750 115 357	NADELKRANZ	NEEDLE CAGE	CAGE A AIG.			1	1	1	1	1	1					
060	2094 213 010 KPL.	KUPPLUNGSGLOCKE	BELL HOUSING	CLOCHE D'EMBR.			1										
	2094 213 013 KPL.	KUPPLUNGSGLOCKE	BELL HOUSING	CLOCHE D'EMBR.				1	1	1	1	1					
070	0501 313 704	FEDERPACKET	CUP SPRING	RONDELLE BELLEV			1	1	1	1	1	1					
080	2094 313 063	DRUCKPLATTE	PRESSURE PLATE	PLAQUE PRESSION			1	1	1	1	1	1					
090	2094 313 055	DRUCKBOLZEN	PRESSURE PIN	BOULON PRESSION			3	3	3	3	3	3					
110	2094 313 061	INNENL.TRAEGER	I.DISC CARRIER	PORTE-DISQ.INT.			1	1	1	1	1	1					
114	1043 333 128	VERSCHL.DECKEL	SEALING CAP	COUVERCLE			14	14	14	14	14	14					

Gruppe 2094 113 FAHRKUPPLUNG
 Group DRIVE CLUTCH
 Groupe EMBRAYAGE

Stückzahl nach Ausführung / Quantity per model /
 Nombre par modèle

2094 004

11.11.94

Bild Nr. Fig. No. Fig. No.	Teilnummer Partnumber No. de pièce	Benennung	Description	Désignation	Änderung Modification Modification	alle all tous	Stückzahl nach Ausführung / Quantity per model / Nombre par modèle								
							002	003	004	005	006	007			
120	0630 531 065 50X3 DIN 471	SICHERUNGSRING	RETAINING RING	JONC D'ARRET			1	1	1	1	1	1			
130	0750 140 049	INNENLAMELLE	I.CLUTCH DISC	DISQUE INT.			7	7	7	7	7	7			
140	2094 313 052 2094 313 053 2094 313 054	INNENLAMELLE WAHLWEISE A=2,9 A=3,2 A=3,5	I.CLUTCH DISC OPTIONAL	DISQUE INT. EN OPTION			1 1 1	1 1 1	1 1 1	1 1 1	1 1 1	1 1 1			
150	2094 213 009	BELAGLAMELLE	LIN.CLUTCH DISC	DISQUE GARNIT.			9	9	9	9	9	9			
154	0501 314 522	FEDER	SPRING WASHER	RONDELLE ELAST.			9	9	9	9	9	9			
160	0750 101 129 0750 101 130	ENDSCHEIBE WAHLWEISE S=4,9 S=5,7	END SHIM OPTIONAL	RONDELLE EN OPTION			1 1	1 1	1 1	1 1	1 1	1 1			
170	2094 313 049	DRUCKRING	PRESSURE RING	CONE SERRAGE			1	1	1	1	1	1			
180	0630 513 137 SB 137	SPRENGRING	SNAP RING	CIRCLIP			1	1	1	1	1	1			
190	2094 313 050	KOLBEN	PISTON	PISTON			1	1	1	1	1	1			
194	0501 313 668	DICHTRING	SEALING RING	BAGUE ETANCH.			1	1	1	1	1	1			
200	0732 042 353	DRUCKFEDER	COMPR.SPRING	RESSORT PRESS.			1	1	1	1	1	1			
210	0501 312 243	DICHTRING	SEALING RING	BAGUE ETANCH.			2	2	2	2	2	2			
220	0501 312 244	DICHTRING	SEALING RING	BAGUE ETANCH.			1	1	1	1	1	1			
230	2094 313 051 2094 313 065	BUCHSE BUCHSE	BUSH BUSH	DOUILLE DOUILLE			1		1	1	1	1	1		
240	2094 313 056	BUCHSE	BUSH	DOUILLE			1	1	1	1	1	1			
244	0630 531 288 67X2,5 A67	SICHERUNGSRING	RETAINING RING	JONC D'ARRET			1	1	1	1	1	1			

Gruppe 2094 113 FAHRKUPPLUNG
 Group DRIVE CLUTCH
 Groupe EMBRAYAGE

Stückzahl nach Ausführung / Quantity per model /
 Nombre par modèle

2094 004

11.11.94

Bild Nr. Fig. No. Fig. No.	Teilnummer Partnumber No. de pièce	Benennung	Description	Désignation	Änderung Modification Modification	alle all tous	2094 004							11.11.94		
							002	003	004	005	006	007				
250	0631 329 078 8 X 18 DIN 1481	SPANNSTIFT	SLOT.PIN	GOUPILLE ELAST.			1	1	1	1	1	1				
260	2094 313 059	ROHR	PIPE	TUBE			1	1	1	1	1	1				
270		SCHÉIBE WAHLWEISE	WASHER OPTIONAL	RONDELLE EN OPTION												
	0730 109 582	S=1,45					1	1	1	1	1	1				
	0730 109 583	S=1,55					1	1	1	1	1	1				
	0730 109 584	S=1,65					1	1	1	1	1	1				
	0730 109 585	S=1,75					1	1	1	1	1	1				
	0730 109 586	S=1,85					1	1	1	1	1	1				
	0730 108 557	S=2,5					1	1	1	1	1	1				
	0730 108 556	S=2,4					1	1	1	1	1	1				
	0730 108 555	S=2,3					1	1	1	1	1	1				
	0730 108 554	S=2,2					1	1	1	1	1	1				
	0730 108 553	S=2,1					1	1	1	1	1	1				
	0730 108 552	S=2,0					1	1	1	1	1	1				
	0730 108 551	S=1,9					1	1	1	1	1	1				
	0730 108 550	S=1,8					1	1	1	1	1	1				
	0730 108 549	S=1,7					1	1	1	1	1	1				
	0730 108 548	S=1,6					1	1	1	1	1	1				
	0730 108 547	S=1,5					1	1	1	1	1	1				

Gruppe 2094 101 GETR.GEHAUSE
 Group GEARBOX HOUSING
 Groupe CARTER DE BOITE

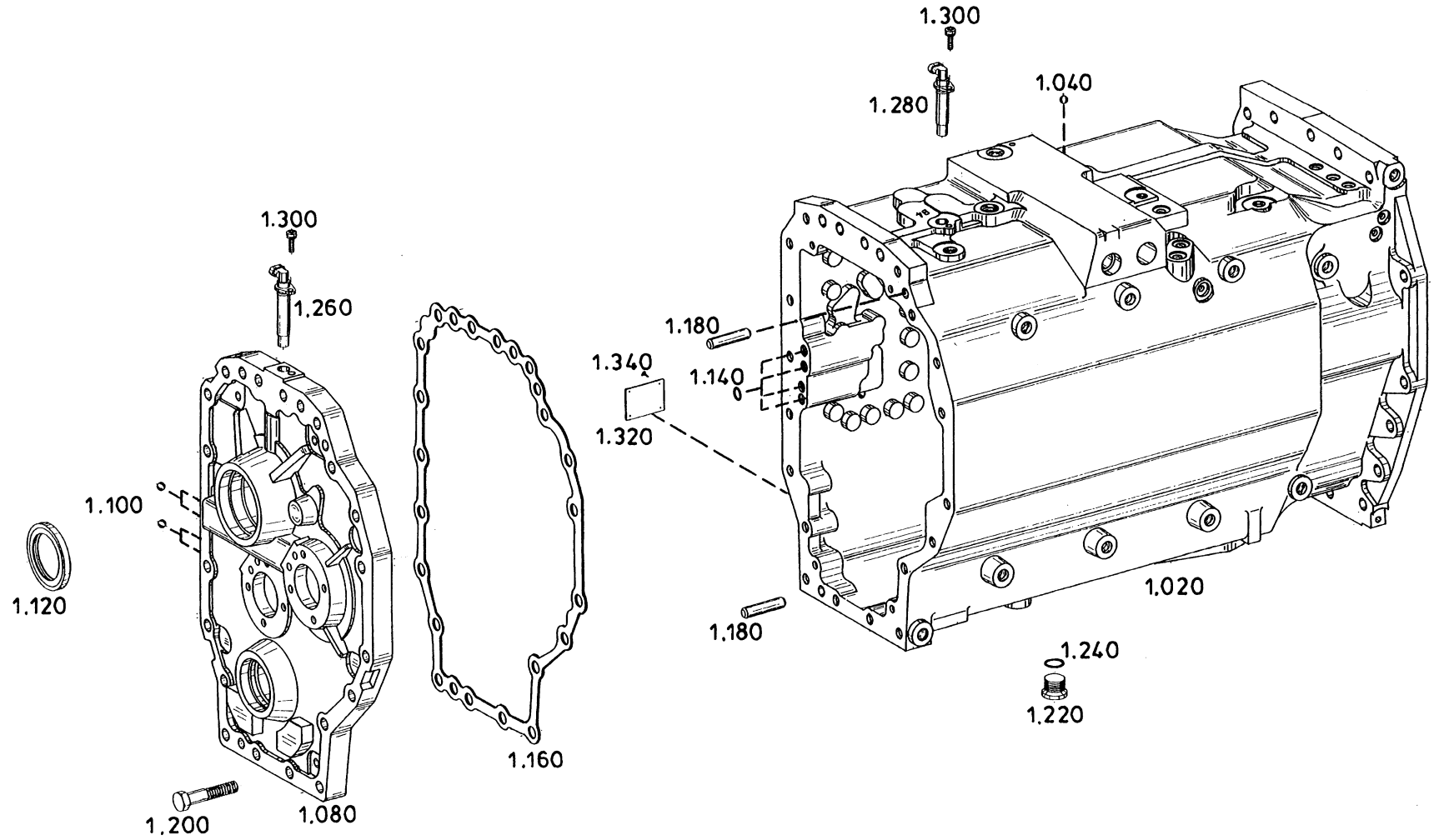

Die Abbildungen sind für die Ausführung nicht verbindlich
 Illustrations are not binding for the design
 Les illustrations ne sont pas obligatoires pour l'exécution

Gruppe 2094 101 GETR.GEHAUSE
 Group GEARBOX HOUSING
 Groupe CARTER DE BOITE

Stückzahl nach Ausführung / Quantity per model /
 Nombre par modèle

2094 004

11.11.94

Bild Nr. Fig. No. Fig. No.	Teilnummer Partnumber No. de pièce	Benennung	Description	Désignation	Änderung Modification Modification	Stückzahl nach Ausführung / Quantity per model / Nombre par modèle									
						alle all tous	002	003	004	005	006	007			
020	2094 301 024	GEHAUSE	HOUSING	CARTER		1									
	2094 301 029	GEHAUSE	HOUSING	CARTER				1	1	1	1	1			
040	0635 460 022	KUGEL	BALL	BILLE		3	2	2	2	2	2				
080	2094 301 028	DECKEL	COVER	COUVERCLE		1									
	2094 301 031	DECKEL	COVER	COUVERCLE				1	1	1	1	1			
100	0635 460 021	KUGEL	BALL	BILLE		4	4	4	4	4	4				
120	0750 111 371	WELLENDICHTRING	SHAFT SEAL	BAGUE ETANCH.		1	1	1	1	1	1				
140	0634 303 085 12 X 3 ZFN 744 NBR -70-10	O-RING	O-RING	JOINT TORIQUE		4	4	4	4	4	4				
160	2094 301 027	DICHTUNG	GASKET	JOINT		1									
	2094 301 030	DICHTUNG	GASKET	JOINT				1	1	1	1	1			
180	0631 306 670 16 M 6X 70 ZFN 6 ST50K * 9S20K	ZYLINDERSTIFT	CYLINDRICAL PIN	GOUPILLE CYL.		2	2	2	2	2	2				
200	0636 011 356 M 12 X 45 DIN 931 10.9	6KT.SCHRAUBE	HEXAGON SCREW	VIS HEXAGONALE		4	4	4	4	4	4				
220	0636 302 009 M 33X2 DIN 908 ST	VERSCHL.SCHR.	SCREW PLUG	VIS FERMETURE		1	1	1	1	1	1				
240	0634 303 312 30 X 2,5 ZFN 744 NBR -70-10	O-RING	O-RING	JOINT TORIQUE		1	1	1	1	1	1				
260	0501 209 178	DREHZAHLGEBER	SPEED TRANSMITT	CAPTEUR TACHYM.		1									

Gruppe 2094 101 GETR.GEHAEUSE
 Group GEARBOX HOUSING
 Groupe CARTER DE BOITE

Stückzahl nach Ausführung / Quantity per model /
 Nombre par modèle

2094 004

11.11.94

Bild Nr. Fig. No. Fig. No.	Teilnummer Partnumber No. de pièce	Benennung	Description	Désignation	Änderung Modification Modification	Stückzahl nach Ausführung / Quantity per model / Nombre par modèle								
						alle all tous	002	003	004	005	006	007		
	0501 209 644	DREHZAHLGEBER	SPEED TRANSMITT	CAPTEUR TACHYM.				1	1	1	1	1		
280	0501 209 177	DREHZAHLGEBER	SPEED TRANSMITT	CAPTEUR TACHYM.		1								
	0501 209 643	DREHZAHLGEBER	SPEED TRANSMITT	CAPTEUR TACHYM.			1	1	1	1	1			
300	0636 101 027 M 8 X 20 DIN 912 8.8	ZYL.SCHRAUBE	CAP SCREW	VIS TETE CYL.		2	2	2	2	2	2			
320	0730 365 124	BAUMUSTERSCHILD	TYPE PLATE	PLAQUE SIGNALET		1	1	1	1	1	1			
340	0631 311 009 3 X 5 DIN 1476 ST	KERBNAGEL	GROOVED STUD	RIVET CANNELE		4	4	4	4	4	4			
---	0637 885 219 MR 0080 M14X1,5	ENTLUEFTER	BREATHER	RENIFLARD		2								

Gruppe 2094 114 KRIECHGANG
Group CRAWLER
Groupe VIT.EXTRA-LENTE

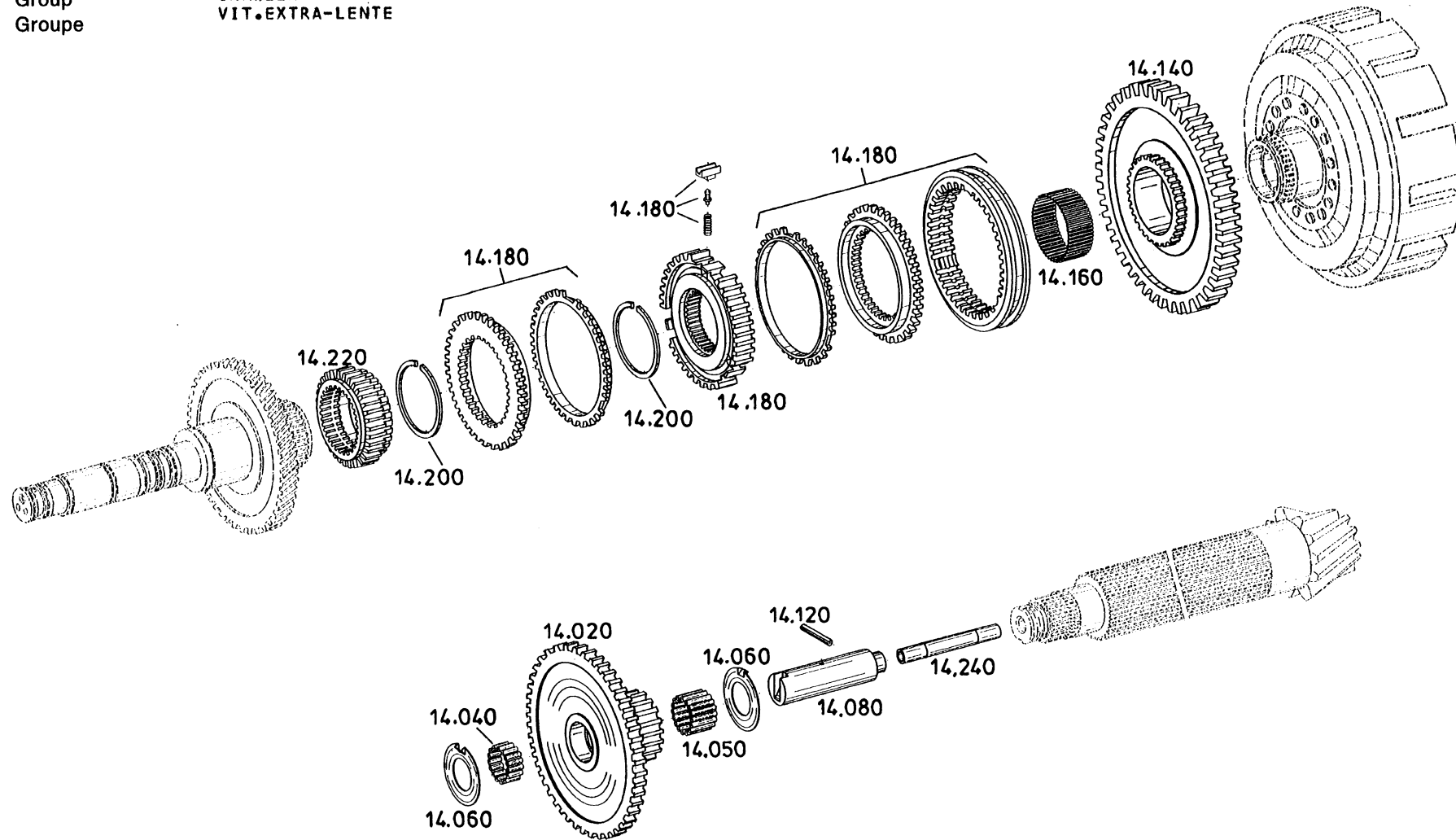

Die Abbildungen sind für die Ausführung nicht verbindlich
Illustrations are not binding for the design
Les illustrations ne sont pas obligatoires pour l'exécution

Gruppe 2094 114 KRIECHGANG
 Group CRAWLER
 Groupe VIT.EXTRA-LENTE

Stückzahl nach Ausführung / Quantity per model /
 Nombre par modèle

2094 004

11.11.94

Bild Nr. Fig. No. Fig. No.	Teilnummer Partnumber No. de pièce	Benennung	Description	Désignation	Änderung Modification Modification	alle all tous	2094 004							11.11.94		
							002	003	004	005	006	007				
020	2094 314 020 Z=69/18	DOPPELRAD	DOUBLE GEAR	PIGNON DOUBLE			1	1	1	1	1	1				
040	0750 115 357	NADELKRANZ	NEEDLE CAGE	CAGE A AIG.			1	1	1	1	1	1				
050	0735 320 114	NADELKAEFIG	NEEDLE CAGE	CAGE A AIG.			1	1	1	1	1	1				
060	0730 102 047	ANLAUFSCHEIBE	THRUST WASHER	RONDELLE BUTEE			2	2	2	2	2	2				
080	2094 314 013	BOLZEN	PIN	AXE			1	1	1	1	1	1				
120	0631 329 072 6 X 40 DIN 1481	SPANNSTIFT	SLOT.PIN	GOUPILLE ELAST.			1	1	1	1	1	1				
140	2094 314 019 Z=60	ZAHNRAD	GEAR	PIGNON			1	1	1	1	1	1				
160	0750 115 359	NADELKRANZ	NEEDLE CAGE	CAGE A AIG.			1	1	1	1	1	1				
180	6002 000 921	SYNCHRONISIERG.	SYNCHRONIZER	SYNCHRONISATION			1	1	1	1	1	1				
200	0630 513 123 SW 63	SPRENGRING	SNAP RING	CIRCLIP			2	2	2	2	2	2				
220	2094 314 015 Z=32	ZAHNRAD	GEAR	PIGNON			1	1	1	1	1	1				
240	2094 314 007	ROHR	PIPE	TUBE			1	1	1	1	1	1				

Gruppe 2094 103 VORGELEGEWELLE
 Group LAYSHAFT
 Groupe ARBRE INTERM.

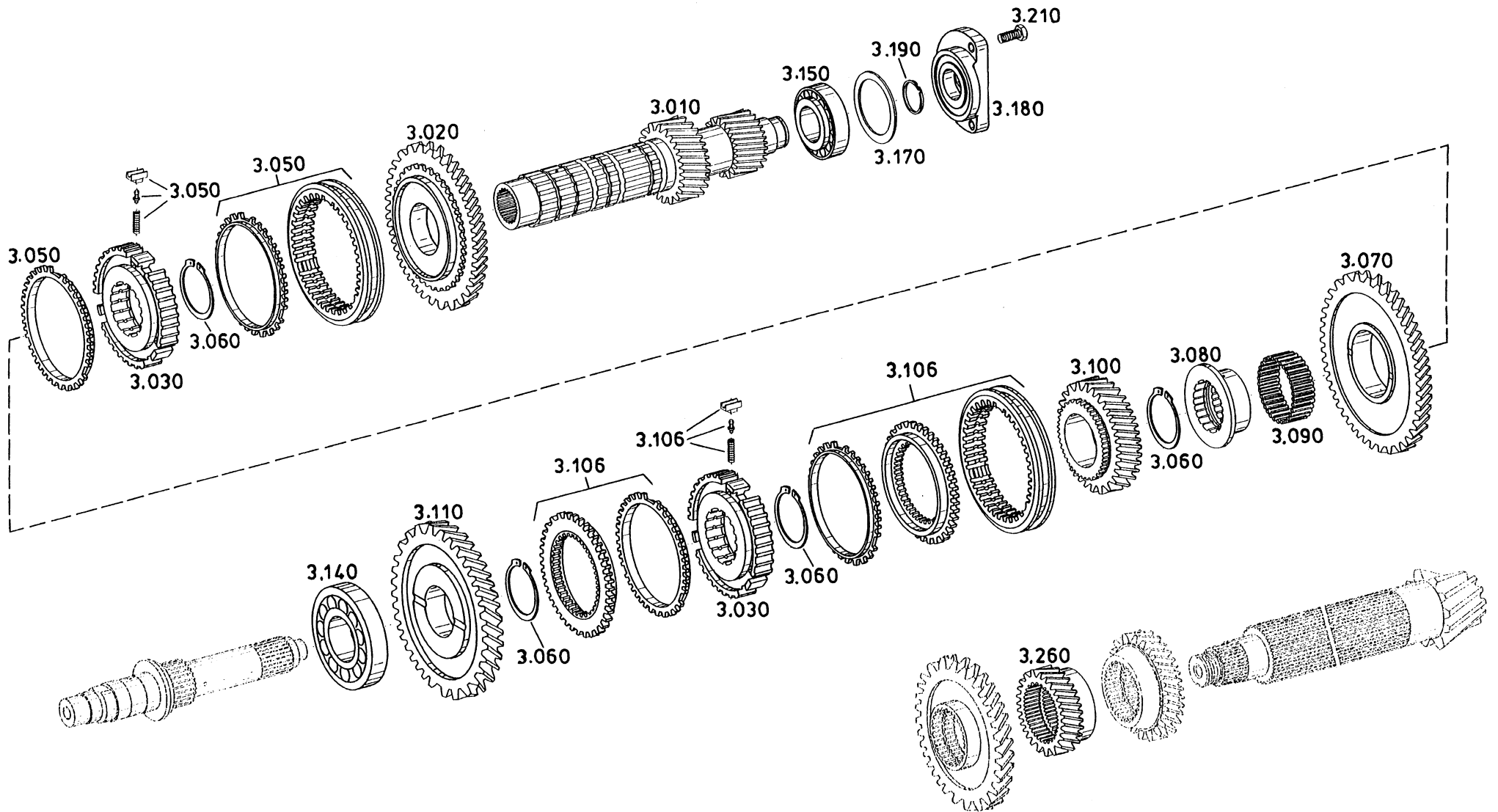

Die Abbildungen sind für die Ausführung nicht verbindlich
 Illustrations are not binding for the design
 Les illustrations ne sont pas obligatoires pour l'exécution

Gruppe 2094 103 VORGELEGEWELLE
 Group LAYSHAFT
 Groupe ARBRE INTERM.

Stückzahl nach Ausführung / Quantity per model /
 Nombre par modèle

2094 004

11.11.94

Bild Nr. Fig. No. Fig. No.	Teilnummer Partnumber No. de pièce	Benennung	Description	Désignation	Änderung Modification Modification	2094 004							11.11.94		
						alle all tous	002	003	004	005	006	007			
010	2094 303 036	VORGELEGEWELLE	LAYSHAFT	ARBRE INTERM.			1	1	1	1	1	1			
	Z=22 RE														
020	2094 303 038	ZAHNRAD	GEAR	PIGNON			1	1	1	1	1	1			
	Z=47/5.G														
030	6002 306 081	SYNCHRONKOERPER	SYNCHRO.BODY	MOYEU SYNCHRON.	KO1634/94		2	2	2	2	2	2			
	AUSLAUFTEIL		TERMINATING DATE	MOMENT TERMNAISON											
050	6002 000 936	SYNCHRONISIERG.	SYNCHRONIZER	SYNCHRONISATION	KO1634/94		1	1	1	1	1	1			
	ANLAUFTEIL		INTRODUCTION DATE	MOMENT.D.DEMARRAGE											
	6002 199 022	SYNCHRONTEILE			KO1634/94		1	1	1	1	1	1			
	AUSLAUFTEIL		TERMINATING DATE	MOMENT TERMNAISON											
060	0730 501 442	SICHERUNGSRING	RETAINING RING	JONC D'ARRET			4	4	4	4	4	4			
070	2094 303 048	ZAHNRAD	GEAR	PIGNON			1	1	1	1	1	1			
	Z=58														
080		BUCHSE	BUSH	DOUILLE											
		WAHLWEISE	OPTIONAL	EN OPTION											
	2094 303 044	L=33.1					1	1	1	1	1	1			
	2094 303 045	L=33.2					1	1	1	1	1	1			
	2094 303 046	L=33.3					1	1	1	1	1	1			
	2094 303 047						1	1	1	1	1	1			
090	0750 115 081	NADELKAEFIG	NEEDLE CAGE	CAGE A AIG.			1	1	1	1	1	1			
100	2094 303 042	ZAHNRAD	GEAR	PIGNON			1	1	1	1	1	1			
	Z=25/3.G														
106	6002 000 935	SYNCHRONISIERG.	SYNCHRONIZER	SYNCHRONISATION	KO1634/94		1	1	1	1	1	1			
	ANLAUFTEIL		INTRODUCTION DATE	MOMENT.D.DEMARRAGE											
	6002 199 021	SYNCHRONTEILE			KO1634/94		1	1	1	1	1	1			
	AUSLAUFTEIL		TERMINATING DATE	MOMENT TERMNAISON											
110	2094 303 041	ZAHNRAD	GEAR	PIGNON			1	1	1	1	1	1			
	Z=35/4.G														
140	0750 117 588	ROLLENLAGER	ROLLER BEARING	ROULEM.A ROUL.			1	1	1	1	1	1			
150	0750 117 618	ROLLENLAGER	ROLLER BEARING	ROULEM.A ROUL.			1	1	1	1	1	1			
170		AUSGL.SCHEIBE	SHIM	RONDELLE											
		WAHLWEISE	OPTIONAL	EN OPTION											
	1232 304 085	S=2,6					1	1	1	1	1	1			
	1232 304 084	S=2,55					1	1	1	1	1	1			
	1232 304 083	S=2,5					1	1	1	1	1	1			
	1232 304 082	S=2,45					1	1	1	1	1	1			
	1232 304 061	S=2,4					1	1	1	1	1	1			
	1232 304 081	S=2.35					1	1	1	1	1	1			
	1232 304 080	S=2.3					1	1	1	1	1	1			

Gruppe 2094 103 VORGELEGEWELLE
 Group LAYSHAFT
 Groupe ARBRE INTERM.

Stückzahl nach Ausführung / Quantity per model /
 Nombre par modèle

2094 004

11.11.94

Bild Nr. Fig. No. Fig. No.	Teilnummer Partnumber No. de pièce	Benennung	Description	Désignation	Änderung Modification Modification	alle all tous	2094 004								
							002	003	004	005	006	007			
	1232 304 079	S=2.25					1	1	1	1	1	1			
	1232 304 078	S=2.2					1	1	1	1	1	1			
	1232 304 077	S=2,15					1	1	1	1	1	1			
	1232 304 032	S=2,1					1	1	1	1	1	1			
	1232 304 076	S=2,05					1	1	1	1	1	1			
	1232 304 075	S=2,0					1	1	1	1	1	1			
	1232 304 074	S=1,95					1	1	1	1	1	1			
	1232 304 033	S=1,9					1	1	1	1	1	1			
	1232 304 073	S=1,85					1	1	1	1	1	1			
	1232 304 059	S=1,8					1	1	1	1	1	1			
	1232 304 058	S=1,75					1	1	1	1	1	1			
	1232 304 049	S=1,7					1	1	1	1	1	1			
	1232 304 057	S=1,65					1	1	1	1	1	1			
	1232 304 056	S=1,6					1	1	1	1	1	1			
180	2094 303 006	DECKEL	COVER	COUVERCLE			1	1	1	1	1	1			
190	0634 402 540 35 X 2 DIN 34118	R-RING SH P KA	PISTON RING	SEGMENT			1	1	1	1	1	1			
210	0636 015 124 M 10 X 28 DIN 933 8.8	6KT.SCHRAUBE	HEXAGON SCREW	VIS HEXAGONALE			3	3	3	3	3	3			
260	2094 304 029 Z=27/6.G	ZAHNRAD	GEAR	PIGNON			1	1	1	1	1	1			

Gruppe 2094 104 HAUPTWELLE
 Group MAIN SHAFT
 Groupe ARBRE PRINCIPAL

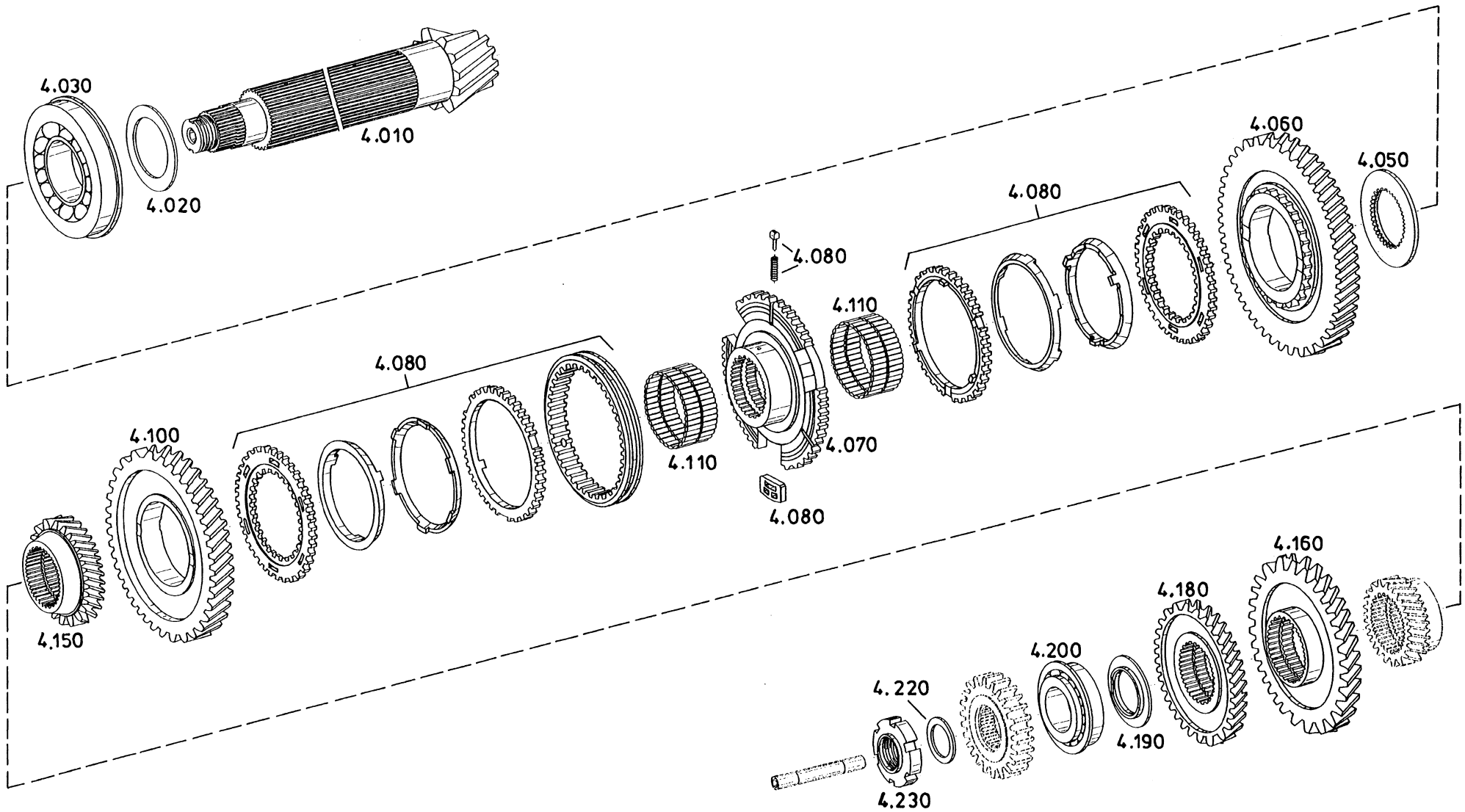

Die Abbildungen sind für die Ausführung nicht verbindlich
 Illustrations are not binding for the design
 Les illustrations ne sont pas obligatoires pour l'exécution

Gruppe 2094 104 HAUPTWELLE
 Group MAIN SHAFT
 Groupe ARBRE PRINCIPAL

Stückzahl nach Ausführung / Quantity per model /
 Nombre par modèle

2094 004

11.11.94

Bild Nr. Fig. No. Fig. No.	Teilnummer Partnumber No. de pièce	Benennung	Description	Désignation	Änderung Modification Modification	alle all tous	2094 004							11.11.94				
							002	003	004	005	006	007						
010	2094 304 051	HAUPTWELLE	MAIN SHAFT	ARBRE PRINCIPAL			1											
	Z=10 LI																	
	2094 304 052	HAUPTWELLE	MAIN SHAFT	ARBRE PRINCIPAL						1					1			
	Z=10 LI																	
	2094 304 053	HAUPTWELLE	MAIN SHAFT	ARBRE PRINCIPAL						1								
020	2094 304 054	HAUPTWELLE	MAIN SHAFT	ARBRE PRINCIPAL						1				1				
	Z=10 LI																	
			SCHEIBE	WASHER	RONDELLE													
			WAHLWEISE	OPTIONAL	EN OPTION													
	0730 107 723	S=3,4					1	1	1	1	1	1	1	1	1	1	1	
	0730 107 722	S=3,35					1	1	1	1	1	1	1	1	1	1	1	
	0730 107 721	S=3,3					1	1	1	1	1	1	1	1	1	1	1	
	0730 107 720	S=3,25					1	1	1	1	1	1	1	1	1	1	1	
	0730 107 719	S=3,20					1	1	1	1	1	1	1	1	1	1	1	
	0730 107 718	S=3,15					1	1	1	1	1	1	1	1	1	1	1	
	0730 107 717	S=3,1					1	1	1	1	1	1	1	1	1	1	1	
	0730 107 724	S=3,05					1	1	1	1	1	1	1	1	1	1	1	
	0730 107 716	S=3,0					1	1	1	1	1	1	1	1	1	1	1	
	0730 108 426	S=3,45					1	1	1	1	1	1	1	1	1	1	1	
	0730 108 427	S=3,50					1	1	1	1	1	1	1	1	1	1	1	
	0730 108 428	S=3,55					1	1	1	1	1	1	1	1	1	1	1	
	0730 108 429	S=3,60					1	1	1	1	1	1	1	1	1	1	1	
	030	0750 117 499	ROLLENLAGER	ROLLER BEARING	ROULEM.A ROUL.			1	1	1	1	1	1	1	1	1	1	1
	050	2094 304 038	ANLAUFSCHEIBE	THRUST WASHER	RONDELLE BUTEE			1	1	1	1	1	1	1	1	1	1	1
	060	2094 304 039	ZAHNRAD	GEAR	PIGNON			1	1	1	1	1	1	1	1	1	1	1
	Z=69/1.G																	
070	6002 305 972	SYNCHRONKOERPER	SYNCHRO.BODY	MOYEU SYNCHRON.			1	1	1	1	1	1	1	1	1	1	1	
	ZF-D155/																	
080	6002 199 020	SYNCHRONTEILE					1	1	1	1	1	1	1	1	1	1	1	
100	2094 304 040	ZAHNRAD	GEAR	PIGNON			1	1	1	1	1	1	1	1	1	1	1	
	Z=51/2.G																	
110	0735 321 219	NADELKRANZ	NEEDLE CAGE	CAGE A AIG.	K02373/94		4	4	4	4	4	4	4	4	4	4	4	
		ANLAUFTEIL	INTRODUCTION DATE	MOMENT.D.DEMARRAGE														
150	0899 313 655	NADELKRANZ	NEEDLE CAGE	CAGE A AIG.	K02373/94		2	2	2	2	2	2	2	2	2	2	2	
		AUSLAUFTEIL	TERMINATING DATE	MOMENT TERMNAISON														
160	2094 304 042	ZAHNRAD	GEAR	PIGNON			1	1	1	1	1	1	1	1	1	1	1	
	Z=31/5.G																	
160	2094 304 043	ZAHNRAD	GEAR	PIGNON			1	1	1	1	1	1	1	1	1	1	1	
	Z=38/3.G																	

Gruppe 2094 104 HAUPTWELLE
 Group MAIN SHAFT
 Groupe ARBRE PRINCIPAL

Stückzahl nach Ausführung / Quantity per model /
 Nombre par modèle

2094 004

11.11.94

Bild Nr. Fig. No. Fig. No.	Teilnummer Partnumber No. de pièce	Benennung	Description	Désignation	Änderung Modification Modification	alle all tous	2094 004							11.11.94		
							002	003	004	005	006	007				
180	2094 304 044	ZAHNRAD	GEAR	PIGNON			1	1	1	1	1	1				
	Z=36/4.G															
190		AUSGL. SCHEIBE WAHLWEISE	SHIM OPTIONAL	RONDELLE EN OPTION												
	0730 108 067	S=9,00					1	1	1	1	1	1				
	0730 108 068	S=8,90					1	1	1	1	1	1				
	0730 108 074	S=8,80					1	1	1	1	1	1				
	0730 108 069	S=8,70					1	1	1	1	1	1				
	0730 108 070	S=8,60					1	1	1	1	1	1				
	0730 108 076	S=8,50					1	1	1	1	1	1				
	0730 108 071	S=8,40					1	1	1	1	1	1				
	0730 108 072	S=8,30					1	1	1	1	1	1				
	0730 108 073	S=8,20					1	1	1	1	1	1				
	0730 108 075	S=8,10					1	1	1	1	1	1				
	0730 108 077	S=8,00					1	1	1	1	1	1				
	0730 108 079	S=7,90					1	1	1	1	1	1				
	0730 108 081	S=7,80					1	1	1	1	1	1				
	0730 108 083	S=7,70					1	1	1	1	1	1				
	0730 108 078	S=7,60					1	1	1	1	1	1				
	0730 108 084	S=7,50					1	1	1	1	1	1				
	0730 108 085	S=7,40					1	1	1	1	1	1				
	0730 108 080	S=7,30					1	1	1	1	1	1				
	0730 108 086	S=7,20					1	1	1	1	1	1				
	0730 108 087	S=7,10					1	1	1	1	1	1				
	0730 109 598	S=7,65					1	1	1	1	1	1				
	0730 109 599	S=7,75					1	1	1	1	1	1				
	0730 109 600	S=7,85					1	1	1	1	1	1				
	0730 109 601	S=7,95					1	1	1	1	1	1				
	0730 109 602	S=8,05					1	1	1	1	1	1				
	0730 109 603	S=8,15					1	1	1	1	1	1				
	0730 109 604	S=8,25					1	1	1	1	1	1				
	0730 109 605	S=8,35					1	1	1	1	1	1				
200	0750 117 498	ROLLENLAGER	ROLLER BEARING	ROULEM.A ROUL.			1	1	1	1	1	1				
220		SCHEIBE WAHLWEISE	WASHER OPTIONAL	RONDELLE EN OPTION												
	0730 107 714	S=3,5					1	1	1	1	1	1				
	0730 107 713	S=3,4					1	1	1	1	1	1				
	0730 107 712	S=3,3					1	1	1	1	1	1				
	0730 107 711	S=3,2					1	1	1	1	1	1				
	0730 107 710	S=3,1					1	1	1	1	1	1				
	0730 107 709	S=3,0					1	1	1	1	1	1				
	0730 107 708	S=2,9					1	1	1	1	1	1				

Gruppe 2094 104 HAUPTWELLE
 Group MAIN SHAFT
 Groupe ARBRE PRINCIPAL

Stückzahl nach Ausführung / Quantity per model /
 Nombre par modèle

2094 004

11.11.94

Bild Nr. Fig. No. Fig. No.	Teilnummer Partnumber No. de pièce	Benennung	Description	Désignation	Änderung Modification Modification	alle all tous	2094 004							11.11.94	
							002	003	004	005	006	007			
	0730 107 707	S=2,8					1	1	1	1	1	1			
	0730 107 706	S=2,7					1	1	1	1	1	1			
	0730 107 705	S=2,6					1	1	1	1	1	1			
	0730 107 704	S=2,5					1	1	1	1	1	1			
	0730 107 703	S=2,4					1	1	1	1	1	1			
	0730 107 702	S=2,3					1	1	1	1	1	1			
	0730 107 701	S=2,2					1	1	1	1	1	1			
	0730 107 700	S=2,1					1	1	1	1	1	1			
	0730 107 699	S=2,0					1	1	1	1	1	1			
	0730 109 592	S=2,35					1	1	1	1	1	1			
	0730 109 593	S=2,45					1	1	1	1	1	1			
	0730 109 594	S=2,55					1	1	1	1	1	1			
	0730 109 595	S=2,65					1	1	1	1	1	1			
	0730 109 596	S=2,75					1	1	1	1	1	1			
	0730 109 597	S=2,85					1	1	1	1	1	1			
	0730 109 614	S=2,95					1	1	1	1	1	1			
230	0737 502 164	NUTMUTTER	SLOTTED NUT	ECROU CANNELE			1	1	1	1	1	1			

Gruppe 2094 146 VORDERRADANTR.
 Group FRONT WH.DRIVE
 Groupe ENTRAIN.ROUE AV

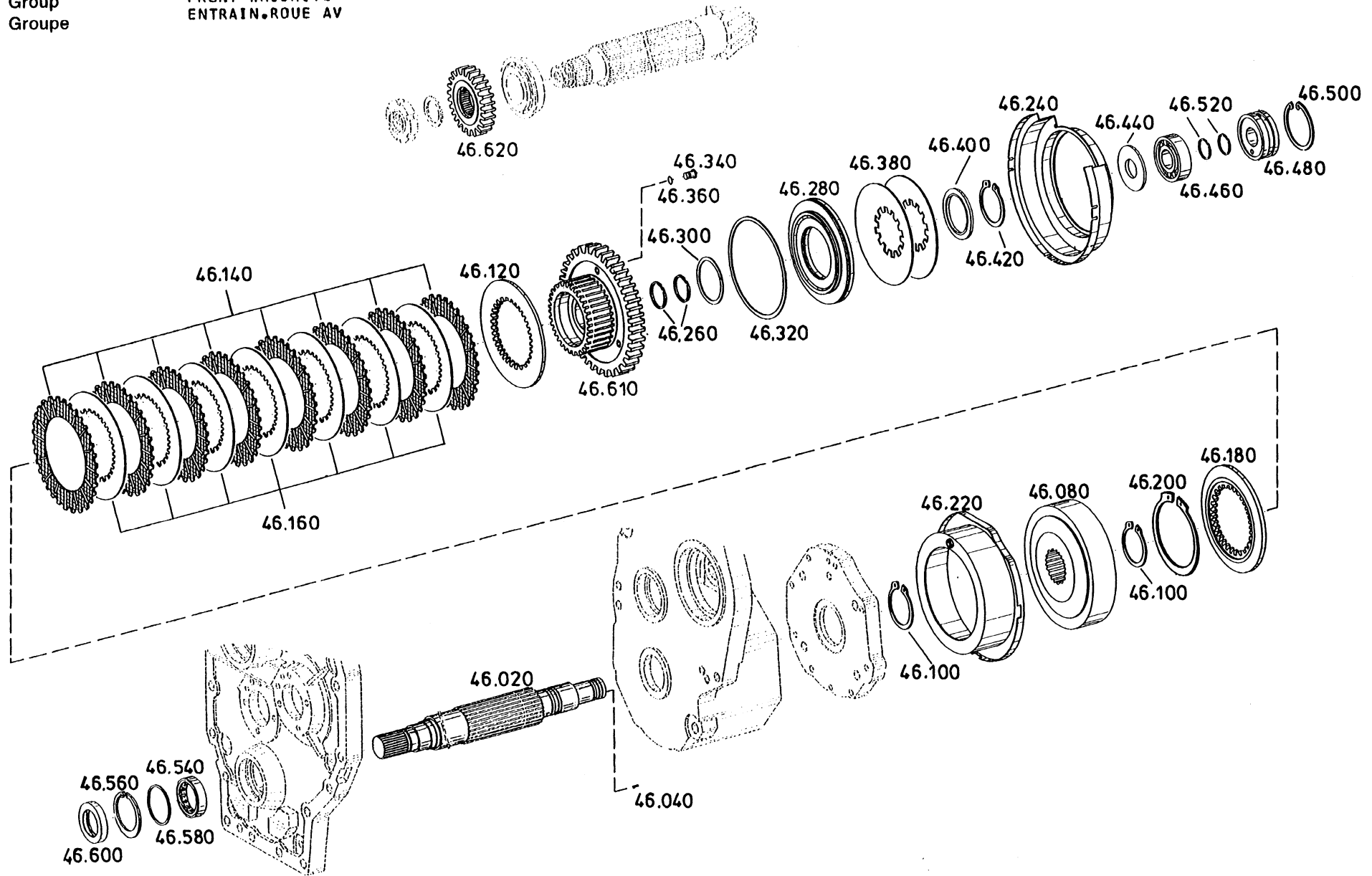

Die Abbildungen sind für die Ausführung nicht verbindlich
 Illustrations are not binding for the design
 Les illustrations ne sont pas obligatoires pour l'exécution

Gruppe 2094 146 VORDERRADANTR.
 Group FRONT WH.DRIVE
 Groupe ENTRAIN.ROUE AV

Stückzahl nach Ausführung / Quantity per model /
 Nombre par modèle

2094 004

11.11.94

Bild Nr. Fig. No. Fig. No.	Teilnummer Partnumber No. de pièce	Benennung	Description	Désignation	Änderung Modification Modification	2094 004							11.11.94		
						alle all tous	002	003	004	005	006	007			
020	2094 346 037	ANTRIEBSWELLE	INPUT SHAFT	ARBRE D'ENTREE			1	1	1	1	1	1			
	Z=28														
040	0631 610 070	GEWINDESTIFT	SET SCREW	GOUJON FILETE			1	1	1	1	1	1			
	M 6 X 8														
	DIN 913														
	8.8														
080	2094 346 002	KUPPLUNGSGLOCKE	BELL HOUSING	CLOCHE D'EMBR.			1	1	1	1	1	1			
100	0630 501 041	SICHERUNGSRING	RETAINING RING	JONC D'ARRET			2	2	2	2	2	2			
	60X2														
	DIN 471														
120		SCHEIBE	WASHER	RONDELLE											
		WAHLWEISE	OPTIONAL	EN OPTION											
	2094 346 042	S=6,55					1	1	1	1	1	1			
	2094 346 008	S=7,0					1	1	1	1	1	1			
	2094 346 043	S=7,45					1	1	1	1	1	1			
140	2094 246 014	AUSSENLEMMELLE	O.CLUTCH DISC	DISQUE EXT.			8	8	8	8	8	8			
160	2002 302 055	INNENLEMMELLE	I.CLUTCH DISC	DISQUE INT.	KO1749/94		7	7	7	7	7	7			
		AUSLAUFTEIL	TERMINATING DATE	MOMENT TERMNAISON											
	4644 308 329	INNENLEMMELLE	I.CLUTCH DISC	DISQUE INT.	KO1749/94		7	7	7	7	7	7			
		ANLAUFTEIL	INTRODUCTION DATE	MOMENT.D.DEMARRAGE											
180	2094 346 009	ENDSCHEIBE	END SHIM	RONDELLE			1	1	1	1	1	1			
200	0630 501 345	SICHERUNGSRING	RETAINING RING	JONC D'ARRET			1	1	1	1	1	1			
	107X4 A107														
220	2094 346 013	ABSCHIRMBLECH	SCREEN SHEET	TOLE DE PROT.			1	1	1	1	1	1			
240	2094 346 014	ABSCHIRMBLECH	SCREEN SHEET	TOLE DE PROT.			1	1	1	1	1	1			
260	0634 402 118	R-RING	PISTON RING	SEGMENT			2	2	2	2	2	2			
	45 X 2	SH													
	DIN 34110														
280	2094 346 038	KOLBEN	PISTON	PISTON			1	1	1	1	1	1			
300	0734 307 170	LIPPENDICHTRING	LIP SEAL.RING	BAGUE ETANCH.L.			1	1	1	1	1	1			
320	0734 307 211	LIPPENDICHTRING	LIP SEAL.RING	BAGUE ETANCH.L.			1	1	1	1	1	1			

Gruppe 2094 146 VORDERRADANTR.
 Group FRONT WH.DRIVE
 Groupe ENTRAIN.ROUE AV

Stückzahl nach Ausführung / Quantity per model /
 Nombre par modèle

2094 004

11.11.94

Bild Nr. Fig. No. Fig. No.	Teilnummer Partnumber No. de pièce	Benennung	Description	Désignation	Änderung Modification Modification	alle all tous	2094 004							11.11.94		
							002	003	004	005	006	007				
340	2094 346 039	BOLZEN	PIN	AXE			3	3	3	3	3	3				
360	0634 313 507 7 X 2,5 ZFN 744 ACM -70-10	O-RING	O-RING	JOINT TORIQUE			3	3	3	3	3	3				
380	0501 314 521	FEDERPAKET	CUP SPRING	RONDELLE BELLEV			1	1	1	1	1	1				
400	0730 107 794	SCHEIBE	WASHER	RONDELLE			1	1	1	1	1	1				
420	0630 531 080 65X4 DIN 471	SICHERUNGSRING	RETAINING RING	JONC D'ARRET			1	1	1	1	1	1				
440	0730 107 679	SCHEIBE	WASHER	RONDELLE			1	1	1	1	1	1				
460	0635 416 038	ROLLENLAGER	ROLLER BEARING	ROULEM.A ROUL.			1	1	1	1	1	1				
480	2094 346 012	OELZUFUEHRRING					1	1	1	1	1	1				
500	0630 502 039 80X2,5 DIN 472	SICHERUNGSRING	RETAINING RING	JONC D'ARRET			1	1	1	1	1	1				
520	0634 402 540 35 X 2 DIN 34118	R-RING SH P KA	PISTON RING	SEGMENT			2	2	2	2	2	2				
540	0750 116 233	KUGELLAGER	BALL BEARING	ROULEM.A BILLES			1	1	1	1	1	1				
560	0630 502 037 75X2,5 DIN 472	SICHERUNGSRING	RETAINING RING	JONC D'ARRET			1	1	1	1	1	1				
580		SCHEIBE WAHLWEISE	WASHER OPTIONAL	RONDELLE EN OPTION												
	0730 108 449	S=2,2					1	1	1	1	1	1				
	0730 108 450	S=2,3					1	1	1	1	1	1				
	0730 108 451	S=2,4					1	1	1	1	1	1				
	0730 108 537	S=2,5					1	1	1	1	1	1				
	0730 108 538	S=2,6					1	1	1	1	1	1				
	0730 109 587	S=2,7					1	1	1	1	1	1				
	0730 109 588	S=2,8					1	1	1	1	1	1				

Gruppe 2094 146 VORDERRADANTR.
 Group FRONT WH.DRIVE
 Groupe ENTRAIN.ROUE AV

Stückzahl nach Ausführung / Quantity per model /
 Nombre par modèle

2094 004

11.11.94

Bild Nr. Fig. No. Fig. No.	Teilnummer Partnumber No. de pièce	Benennung	Description	Désignation	Änderung Modification Modification	Stückzahl nach Ausführung / Quantity per model / Nombre par modèle								
						alle all tous	002	003	004	005	006	007		
600	0750 111 368	WELLENDICHTRING	SHAFT SEAL	BAGUE ETANCH.		1	1	1	1	1	1			
610	2094 246 015	ZAHNRAD	GEAR	PIGNON		1	1	1	1	1	1			
620	2094 304 050 KPL. Z=26	ZAHNRAD	GEAR	PIGNON		1	1	1	1	1	1			

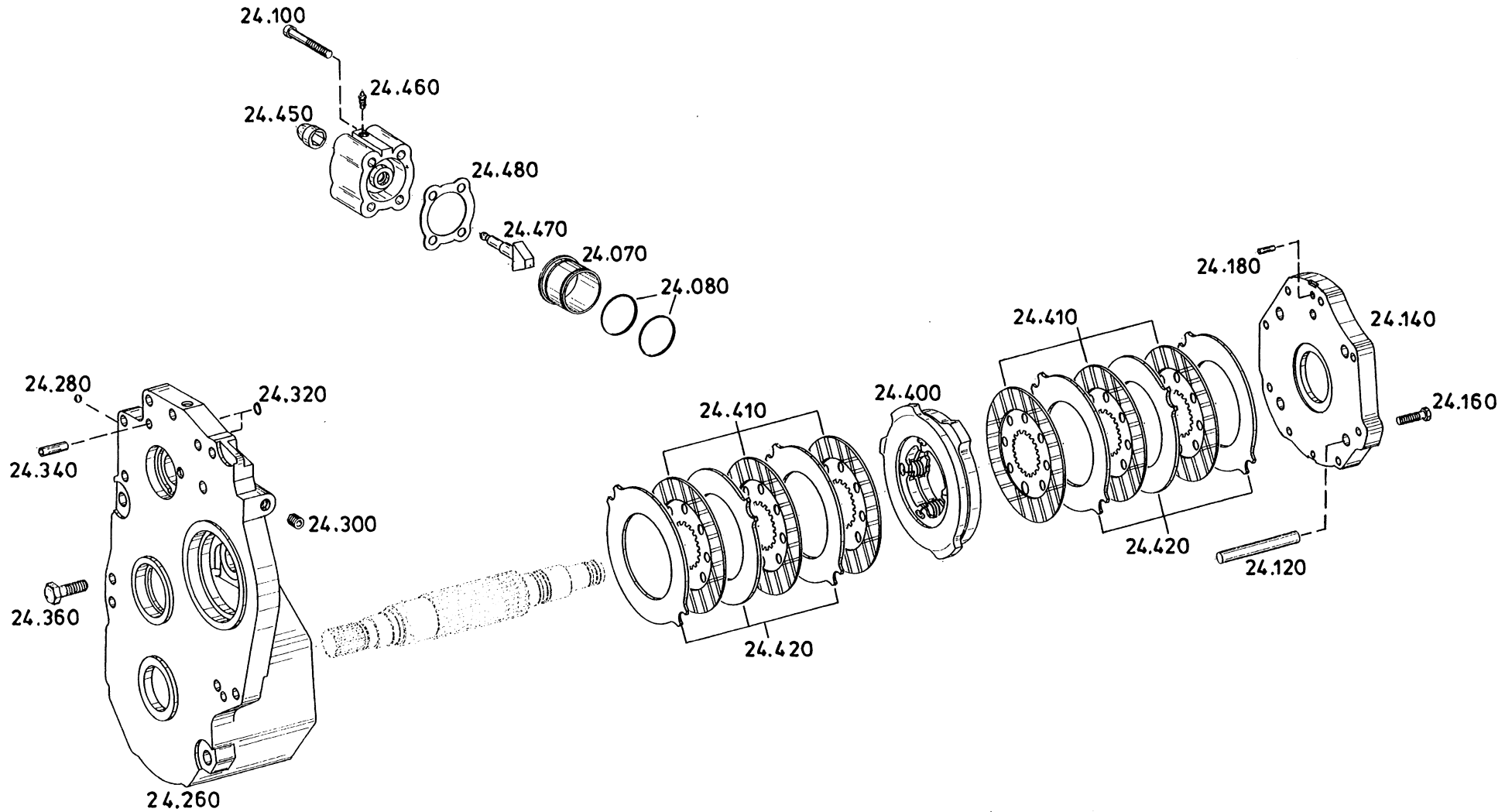

Die Abbildungen sind für die Ausführung nicht verbindlich
 Illustrations are not binding for the design
 Les illustrations ne sont pas obligatoires pour l'execution

Bild Nr. Fig. No. Fig. No.	Teilnummer Partnumber No. de pièce	Benennung	Description	Désignation	Änderung Modification Modification	alle all tous									
							002	003	004	005	006	007			
---	0501 004 720	BREMSE KPL. BESTEHEND AUS BILD NR. 400-420	BRAKE CPL. CONSISTING OF FIG NO. 400-420	FREIN CPL. COMPOSE DE FIG NO. 400-420			1	1	1	1	1	1			
400	0501 209 289	BETAETIGUNGSSCH. KPL.	ACTUATOR PLATE CPL.	RONDELLE CDE CPL. CPL.			1	1	1	1	1	1			
410	0501 314 650	BELAGLAMELLE	LIN.CLUTCH DISC	DISQUE GARNIT.			6	6	6	6	6	6			
420	0501 314 651	AUSSENLAMELLE	O.CLUTCH DISC	DISQUE EXT.			6	6	6	6	6	6			
---	0501 004 721	BREMSZYLINDER KPL. AUSLAUFTEIL BESTEHEND AUS BILD NR. 450-480	BRAKE CYLINDER CPL. TERMINATING DATE CONSISTING OF FIG NO. 450-480	CYLINDRE FREIN CPL. MOMENT TERMNAISON COMPOSE DE FIG NO. 450-480			1	1	1	1	1	1			
450	0501 314 646	SCHUTZKAPPE	PROTECTING CAP	CAPUCHON DE PROTECTION			1	1	1	1	1	1			
460	0501 209 288	ENTLUEFTERV. KPL.	VENT VALVE CPL.	SOUP. PURGE AIR CPL.			1	1	1	1	1	1			
470	0501 314 648	DRUCKKEIL	PRESSURE PIECE	POUSSOIR			1	1	1	1	1	1			
480	0501 314 649	DICHTUNG	GASKET	JOINT			1	1	1	1	1	1			
---	0501 005 418	BREMSZYLINDER KPL. ANLAUFTEIL BESTEHEND AUS BILD NR. 450-480	BRAKE CYLINDER CPL. INTRODUCTION DATE CONSISTING OF FIG NO. 450-480	CYLINDRE FREIN CPL. MOMENT D DEMARRAGE COMPOSE DE FIG NO. 450-480			1	1	1	1	1	1			
450	0501 314 646	SCHUTZKAPPE	PROTECTING CAP	CAPUCHON DE PROTECTION			1	1	1	1	1	1			
460	0501 209 288	ENTLUEFTERV. KPL.	VENT VALVE CPL.	SOUP.PURGE AIR CPL.			1	1	1	1	1	1			
470	0501 314 648	DRUCKKEIL	PRESSURE PIECE	POUSSOIR			1	1	1	1	1	1			
480	0501 315 264	DICHTUNG	GASKET	JOINT			1	1	1	1	1	1			

Gruppe 2094 124 BETR.BREMSE
 Group
 Groupe

Stückzahl nach Ausführung / Quantity per model /
 Nombre par modèle

2094 004

11.11.94

Bild Nr. Fig. No. Fig. No.	Teilnummer Partnumber No. de pièce	Benennung	Description	Désignation	Änderung Modification Modification	alle all tous							
						002	003	004	005	006	007		
070	2094 324 007	BUCHSE	BUSH	DOUILLE		1	1	1	1	1	1		
080	0634 306 271 57 X 2,5 ZFN 744 NBR -70-10	O-RING	O-RING	JOINT TORIQUE		2	2	2	2	2	2		
100	0636 101 335 M 8 X 80 DIN 912 10.9	ZYL.SCHRAUBE	CAP SCREW	VIS TETE CYL.		4	4	4	4	4	4		
120	0731 201 559	BOLZEN	PIN	AXE		4	4	4	4	4	4		
140	2094 324 006	SCHEIBE	WASHER	RONDELLE		1	1	1	1	1	1		
160	0636 010 459 M 10 X 45 DIN 931 10.9	6KT.SCHRAUBE	HEXAGON SCREW	VIS HEXAGONALE		8	8	8	8	8	8		
180	0631 306 071 10 M 6X 16 ZFN 6 ST50K * 9S20K	ZYLINDERSTIFT	CYLINDRICAL PIN	GOUPILLE CYL.		2	2	2	2	2	2		
260	2094 301 025	DECKEL	COVER	COUVERCLE		1	1	1	1	1	1		
280	0635 460 021	KUGEL	BALL	BILLE		8	8	8	8	8	8		
300	0631 610 128 M 14 X12 DIN 913 45H	GEWINDESTIFT	SET SCREW	GOUJON FILETE		3	3	3	3	3	3		
320	0634 303 085 12 X 3 ZFN 744 NBR -70-10	O-RING	O-RING	JOINT TORIQUE		2	2	2	2	2	2		
340	0631 315 561 C 12 X 45 DIN 7979	STIFT	PIN	GOUPILLE		2	2	2	2	2	2		
360	0636 011 024 M 12 X 50 DIN 931 10.9	6KT.SCHRAUBE	HEXAGON SCREW	VIS HEXAGONALE		10	10	10	10	10	10		

Gruppe 2094 106 SCHALTUNG
 Group GEARSHIFT SYST.
 Groupe CHANGEMT.VIT.

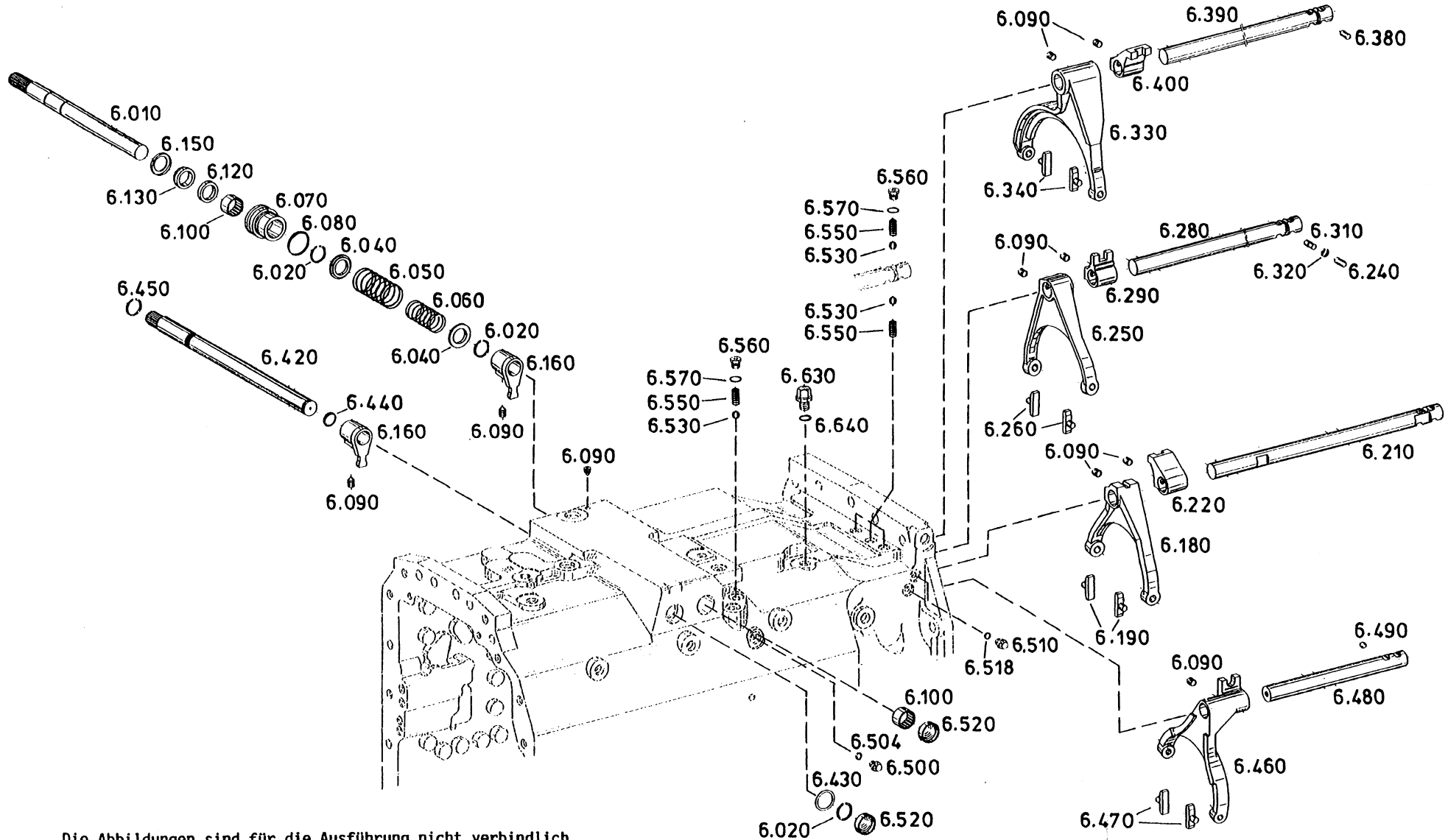

Die Abbildungen sind für die Ausführung nicht verbindlich
 Illustrations are not binding for the design
 Les illustrations ne sont pas obligatoires pour l'exécution

Gruppe 2094 106 SCHALTUNG
 Group GEARSHIFT SYST.
 Groupe CHANGEMT.VIT.

Stückzahl nach Ausführung / Quantity per model /
 Nombre par modèle

2094 004

11.11.94

Bild Nr. Fig. No. Fig. No.	Teilnummer Partnumber No. de pièce	Benennung	Description	Désignation	Änderung Modification Modification	2094 004							11.11.94		
						alle all tous	002	003	004	005	006	007			
010	2094 306 042	SCHALTWELLE	G.SHIFT SHAFT	ARBRE CDE VIT.			1	1	1	1	1	1			
020	0630 513 070 SW 25	SPRENGRING	SNAP RING	CIRCLIP			3	3	3	3	3	3			
040	2094 306 019	SCHEIBE	WASHER	RONDELLE			2	2	2	2	2	2			
050	0732 040 444	DRUCKFEDER	COMPR.SPRING	RESSORT PRESS.			1	1	1	1	1	1			
060	0732 040 728	DRUCKFEDER	COMPR.SPRING	RESSORT PRESS.			1	1	1	1	1	1			
070	2094 306 014	BUCHSE	BUSH	DOUILLE			1	1	1	1	1	1			
080	0634 304 355 37 X 3 ZFN 744 NBR -70-10	O-RING	O-RING	JOINT TORIQUE			1	1	1	1	1	1			
090	1238 306 065	GEWINDESTIFT	SET SCREW	GOUJON FILETE			19	19	19	19	19	19			
100	0635 303 053	NADELHUELSE	NEEDLE SLEEVE	DOUILLE A AIG.			2	2	2	2	2	2			
120	0634 301 303 25 X 35X 7 ZFN 132 NB	WELLENDICHTRING A	SHAFT SEAL	BAGUE ETANCH.			1	1	1	1	1	1			
130	0634 307 367 AS 25X 35X 7	ABSTREIFER X10	ROD WIPER	RACLEUR			1	1	1	1	1	1			
150	2094 306 020	SCHUTZRING	PROTECTING RING	BAGUE PROTECTR.			1	1	1	1	1	1			
160	2094 306 036	SCHALTFINGER	G.SHIFT FINGER	DOIGT DE CDE			2	2	2	2	2	2			
180	2094 306 004	SCHALTGABEL	GEAR SHIFT FORK	FOURCH.PASS.VIT			1	1	1	1	1	1			
190	1290 306 066	GLEITSTEIN	SLIDING PAD	COULISSEAU			2	2	2	2	2	2			
210	2094 306 037	SCHALTSCHIENE	GEAR SHIFT RAIL	GLISSIERE CDE			1								
	2094 306 045	SCHALTSCHIENE	GEAR SHIFT RAIL	GLISSIERE CDE				1	1	1	1	1			
220	2094 306 008	MITNEHMER	DRIVER	ENTRAINEUR			1	1	1	1	1	1			

Gruppe 2094 106 SCHALTUNG
 Group GEARSHIFT SYST.
 Groupe CHANGEMT.VIT.

Stückzahl nach Ausführung / Quantity per model /
 Nombre par modèle

2094 004

11.11.94

Bild Nr. Fig. No. Fig. No.	Teilnummer Partnumber No. de pièce	Benennung	Description	Désignation	Änderung Modification Modification	alle all tous	2094 004							11.11.94		
							002	003	004	005	006	007				
240	0731 208 205	SPERRSTIFT	LOCKING PIN	GOUP. D'ARRET			1	1	1	1	1	1				
250	2094 306 003	SCHALTGABEL	GEAR SHIFT FORK	FOURCH.PASS.VIT			1	1	1	1	1	1				
260	1290 306 066	GLEITSTEIN	SLIDING PAD	COULISSEAU			2	2	2	2	2	2				
280	2094 306 028	SCHALTSCHIENE	GEAR SHIFT RAIL	GLISSIERE CDE			1									
	2094 306 046	SCHALTSCHIENE	GEAR SHIFT RAIL	GLISSIERE CDE				1	1	1	1	1				
290	2094 306 007	MITNEHMER	DRIVER	ENTRAINEUR			1	1	1	1	1	1				
310	0731 201 193	SPERRSTIFT	LOCKING PIN	GOUP. D'ARRET			1	1	1	1	1	1				
320	0630 505 559 B 7 DIN 7993	SPRENGRING	SNAP RING	CIRCLIP			1	1	1	1	1	1				
330	2094 306 029	SCHALTGABEL	GEAR SHIFT FORK	FOURCH.PASS.VIT			1	1	1	1	1	1				
340	1290 306 066	GLEITSTEIN	SLIDING PAD	COULISSEAU			2	2	2	2	2	2				
380	0731 208 225	SPERRSTIFT	LOCKING PIN	GOUP. D'ARRET			1	1	1	1	1	1				
390	2094 306 030	SCHALTSCHIENE	GEAR SHIFT RAIL	GLISSIERE CDE			1									
	2094 306 043	SCHALTSCHIENE	GEAR SHIFT RAIL	GLISSIERE CDE				1	1	1	1	1				
400	2094 306 032	MITNEHMER	DRIVER	ENTRAINEUR			1	1	1	1	1	1				
420	2094 306 041	SCHALTWELLE	G.SHIFT SHAFT	ARBRE CDE VIT.			1	1	1	1	1	1				
	2094 306 047	SCHALTWELLE ANLAUFTEIL	G.SHIFT SHAFT INTRODUCTION DATE	ARBRE CDE VIT. MOMENT.D.DEMARRAGE	KO1582/94			1	1	1	1	1				
430	0730 003 739	SCHEIBE	WASHER	RONDELLE			1	1	1	1	1	1				
440	0634 303 199 20 X 3 ZFN 744 NBR -70-10	O-RING	O-RING	JOINT TORIQUE			1	1	1	1	1	1				
450	0630 505 527 A 25 DIN 7993	SPRENGRING	SNAP RING	CIRCLIP			1	1	1	1	1	1				

Gruppe 2094 106 SCHALTUNG
 Group GEARSHIFT SYST.
 Groupe CHANGEMT.VIT.

Stückzahl nach Ausführung / Quantity per model /
 Nombre par modèle

2094 004

11.11.94

Bild Nr. Fig. No. Fig. No.	Teilnummer Partnumber No. de pièce	Benennung	Description	Désignation	Änderung Modification Modification	alle all tous	2094 004								
							002	003	004	005	006	007			
460	2094 306 038	SCHALTGABEL	GEAR SHIFT FORK	FOURCH.PASS.VIT			1	1	1	1	1	1			
470	1290 306 066	GLEITSTEIN	SLIDING PAD	COULISSEAU			2	2	2	2	2	2			
480	2094 306 039	SCHALTSCHIENE	GEAR SHIFT RAIL	GLISSIERE CDE			1	1	1	1	1	1			
490	0731 208 206	SPERRSTIFT	LOCKING PIN	GOUP. D'ARRET			1	1	1	1	1	1			
500	0636 304 019 M 10X1 DIN 910 ST FE/ZNPHR8F	VERSCHL.SCHR.	SCREW PLUG	VIS FERMETURE			1	1	1	1	1	1			
504	0634 303 280 8 X 1,5 ZFN 744 NBR -70-10	O-RING	O-RING	JOINT TORIQUE			1	1	1	1	1	1			
510	0736 304 151	VERSCHL.SCHR.	SCREW PLUG	VIS FERMETURE			2	2	2	2	2	2			
518	0634 303 280 8 X 1,5 ZFN 744 NBR -70-10	O-RING	O-RING	JOINT TORIQUE			2	2	2	2	2	2			
520	0630 361 039 32 DIN 443 FE/ZNPHR8F	VERSCHL.DECKEL	SEALING CAP	COUVERCLE			2	2	2	2	2	2			
530	0635 460 021	KUGEL	BALL	BILLE			4	7	7	7	7	7			
550	1203 313 004	DRUCKFEDER	COMPR.SPRING	RESSORT PRESS.			4	7	7	7	7	7			
560	0636 302 001 M 12X1,5 DIN 908 ST	VERSCHL.SCHR.	SCREW PLUG	VIS FERMETURE			4	4	4	4	4	4			
570	0634 303 144 9,5 X 2 ZFN 744 NBR -70-10	O-RING	O-RING	JOINT TORIQUE			4	4	4	4	4	4			

Gruppe 2094 106 SCHALTUNG
 Group GEARSHIFT SYST.
 Groupe CHANGEMT.VIT.

Stückzahl nach Ausführung / Quantity per model /
 Nombre par modèle

2094 004

11.11.94

Bild Nr. Fig. No. Fig. No.	Teilnummer Partnumber No. de pièce	Benennung	Description	Désignation	Änderung Modification Modification	Stückzahl nach Ausführung / Quantity per model / Nombre par modèle										
						alle all tous	002	003	004	005	006	007				
630	0636 305 011 AM 18X1,5 DIN 7604 ST	VERSCHL.SCHR.	SCREW PLUG	VIS FERMETURE			1									
640	0634 306 524 15 X 2 ZFN 744 NBR -70-10	O-RING	O-RING	JOINT TORIQUE			1									

Gruppe 2094 152 SCHALTUNG
 Group GEARSHIFT SYST.
 Groupe CHANGEMT.VIT.

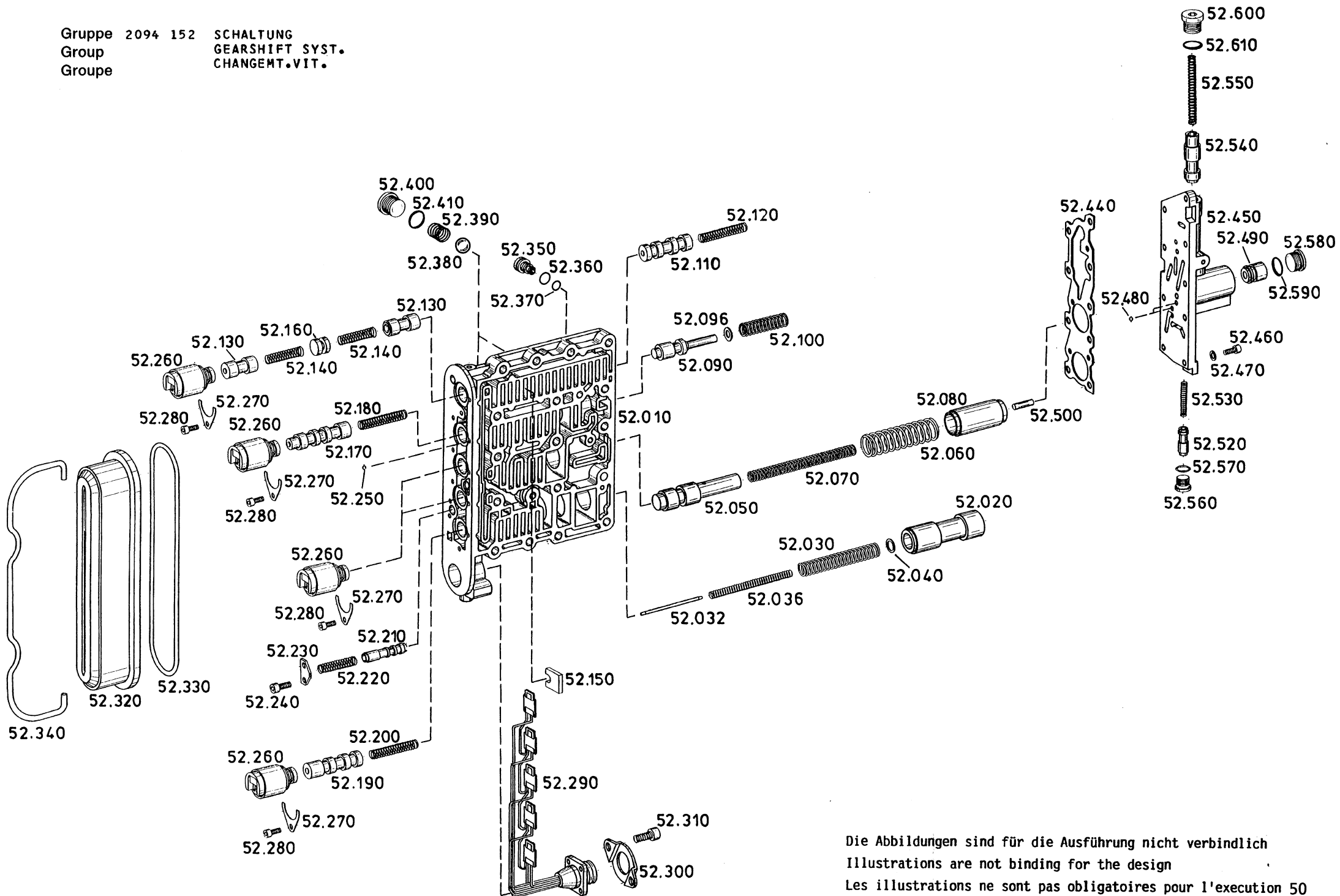

Die Abbildungen sind für die Ausführung nicht verbindlich
 Illustrations are not binding for the design
 Les illustrations ne sont pas obligatoires pour l'exécution 50

Gruppe 2094 152 SCHALTUNG
 Group GEARSHIFT SYST.
 Groupe CHANGEMT.VIT.

Stückzahl nach Ausführung / Quantity per model /
 Nombre par modèle

2094 004

11.11.94

Bild Nr. Fig. No. Fig. No.	Teilnummer Partnumber No. de pièce	Benennung	Description	Désignation	Änderung Modification Modification	alle all tous	2094 004								
							002	003	004	005	006	007			
010	2094 352 043	VENTILGEHAEUSE	VALVE HOUSING	CARTER DE VALVE			1	1	1	1	1	1			
020	2093 352 030	KOLBEN	PISTON	PISTON			1	1	1	1	1	1			
030	0732 042 446	DRUCKFEDER	COMPR.SPRING	RESSORT PRESS.			1	1	1	1	1	1			
032	2094 352 042	STIFT	PIN	GOUPILLE					1	1	1	1			
036	0732 040 889	DRUCKFEDER	COMPR.SPRING	RESSORT PRESS.					1	1	1	1			
040		SCHEIBE WAHLWEISE	WASHER OPTIONAL	RONDELLE EN OPTION											
	0630 000 185 10X 16 XO,2 DIN 988						1	1	1	1	1	1			
	0630 000 164 10X 16 XO,3 DIN 988						1	1	1	1	1	1			
	0630 000 148 10X 16 XO,4 PS						1	1	1	1	1	1			
	0630 004 038 10X 16 XO,5 DIN 988						1	1	1	1	1	1			
	0630 004 037 10X 16 X1 DIN 988						1	1	1	1	1	1			
050	2093 352 043	KOLBEN	PISTON	PISTON			1	1	1	1	1	1			
060	0732 042 315	DRUCKFEDER	COMPR.SPRING	RESSORT PRESS.			1	1	1	1	1	1			
070	0732 042 316	DRUCKFEDER	COMPR.SPRING	RESSORT PRESS.			1	1	1	1	1	1			
080	4644 306 377	KOLBEN	PISTON	PISTON			1	1	1	1	1	1			
090	4644 306 509	KOLBEN	PISTON	PISTON			1	1	1	1	1	1			
096	0730 001 411	SCHEIBE	WASHER	RONDELLE			1	1							
100	0732 042 317	DRUCKFEDER	COMPR.SPRING	RESSORT PRESS.			1	1	1	1	1	1			
110	2093 352 034	KOLBEN	PISTON	PISTON			1	1	1	1	1	1			
120	0732 042 025	DRUCKFEDER	COMPR.SPRING	RESSORT PRESS.			1	1	1	1	1	1			

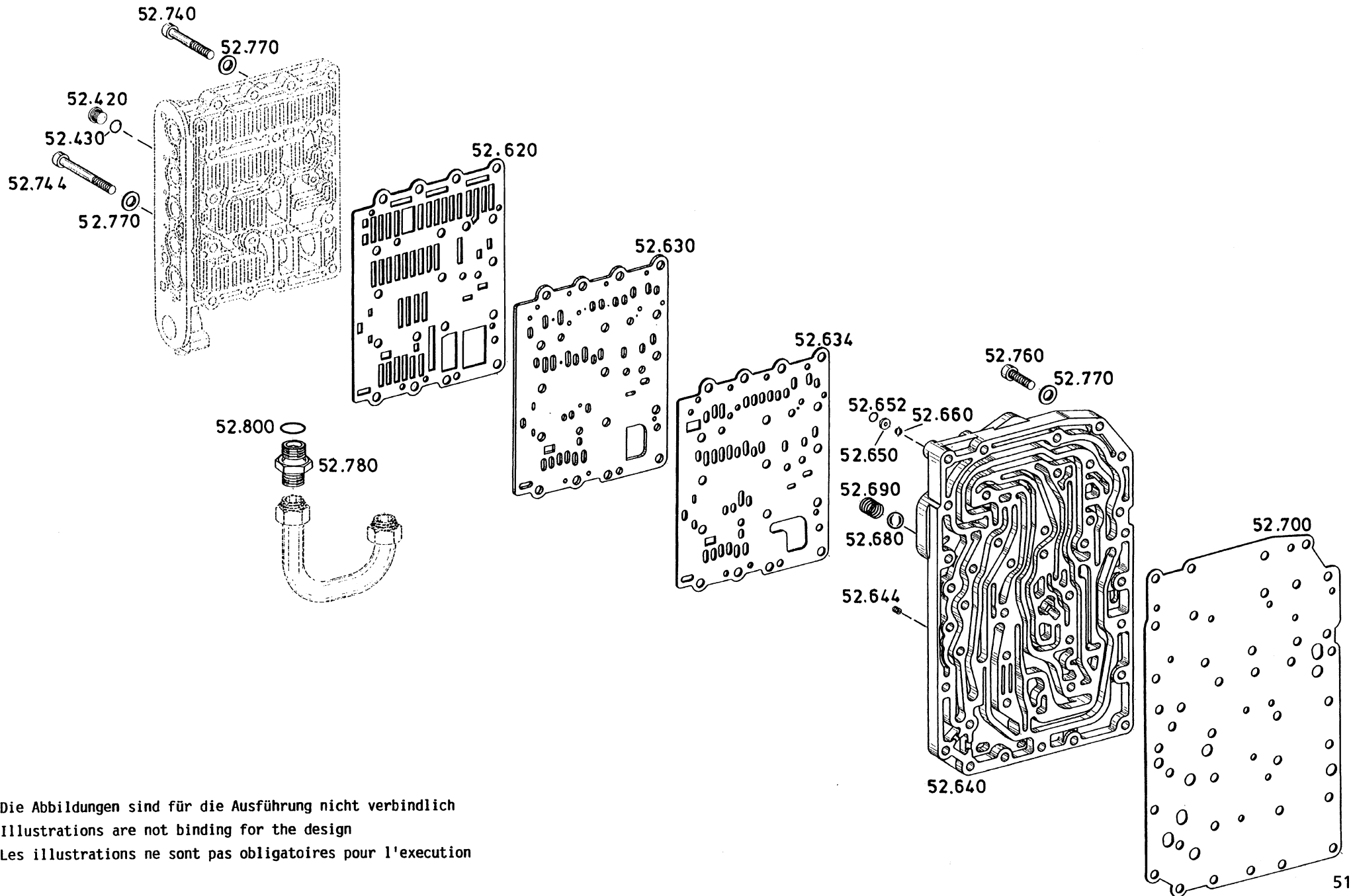

Die Abbildungen sind für die Ausführung nicht verbindlich
 Illustrations are not binding for the design
 Les illustrations ne sont pas obligatoires pour l'exécution

Gruppe 2094 152 SCHALTUNG
 Group GEARSHIFT SYST.
 Groupe CHANGEMT.VIT.

Stückzahl nach Ausführung / Quantity per model /
 Nombre par modèle

2094 004

11.11.94

Bild Nr. Fig. No. Fig. No.	Teilnummer Partnumber No. de pièce	Benennung	Description	Désignation	Änderung Modification Modification	alle all tous	2094 004							11.11.94		
							002	003	004	005	006	007				
130	2093 352 036	KOLBEN	PISTON	PISTON			2	2	2	2	2	2				
140	0732 040 597	DRUCKFEDER	COMPR.SPRING	RESSORT PRESS.			2	2	2	2	2	2				
150	4644 306 234	ANSCHLAGBLECH	STOP PLATE	TOLE D'ARRET			1	1	1	1	1	1				
160	4644 306 267	ANSCHLAG	STOP	BUTEE			1	1	1	1	1	1				
170	2093 352 003	KOLBEN	PISTON	PISTON			1	1	1	1	1	1				
180	0732 042 025	DRUCKFEDER	COMPR.SPRING	RESSORT PRESS.			1	1	1	1	1	1				
190	2093 352 042	KOLBEN	PISTON	PISTON			1	1	1	1	1	1				
200	0732 042 025	DRUCKFEDER	COMPR.SPRING	RESSORT PRESS.			1	1	1	1	1	1				
210	2093 352 015	REDUZIERVERTIL	REDUCTION VALVE	DETENDEUR			1	1	1	1	1	1				
220	0732 042 024	DRUCKFEDER	COMPR.SPRING	RESSORT PRESS.			1	1	1	1	1	1				
230	4644 306 386	HALTEBLECH	FIXING PLATE	TOLE SUPPORT			1	1	1	1	1	1				
240	0636 101 107 M 5 X 10 DIN 912 8.8	ZYL.SCHRAUBE	CAP SCREW	VIS TETE CYL.			2	2	2	2	2	2				
250	0635 460 005	KUGEL	BALL	BILLE			10	10	10	10	10	10				
260	0501 311 654	MAGNETVENTIL	SOLENOID VALVE	ELECTROVANNE			5	5	5	5	5	5				
270	1043 326 045	HALTEBLECH	FIXING PLATE	TOLE SUPPORT			5	5	5	5	5	5				
280	0636 101 107 M 5 X 10 DIN 912 8.8	ZYL.SCHRAUBE	CAP SCREW	VIS TETE CYL.			5	5	5	5	5	5				
290	2093 252 002	KABELBAUM	WIRING HARNESS	FAISCEAU CABLES			1	1	1	1	1	1				
300	4644 306 399	HALTEBLECH	FIXING PLATE	TOLE SUPPORT			1	1	1	1	1	1				

Gruppe 2094 152 SCHALTUNG
 Group GEARSHIFT SYST.
 Groupe CHANGEMT.VIT.

Stückzahl nach Ausführung / Quantity per model /
 Nombre par modèle

2094 004

11.11.94

Bild Nr. Fig. No. Fig. No.	Teilnummer Partnumber No. de pièce	Benennung	Description	Désignation	Änderung Modification Modification	alle all tous	2094 004								
							002	003	004	005	006	007			
310	0636 101 478 M 6 X 14 DIN 912 8.8	ZYL.SCHRAUBE	CAP SCREW	VIS TETE CYL.			2	2	2	2	2	2			
320	4644 206 039	DECKEL	COVER	COUVERCLE			1	1	1	1	1	1			
330	0634 349 606 159,2 X 5,7	O-RING	O-RING	JOINT TORIQUE			1	1	1	1	1	1			
340	4644 306 388	SPANNBUEGEL	CLAMP.BRACKET	COLLIER SERRAGE			1	1	1	1	1	1			
350	2093 352 049 2093 352 047 2093 352 046	BLENDE WAHLWEISE	ORIFICE OPTIONAL	AJUTAGE EN OPTION			1	1	1	1	1	1			
360	0634 303 280 8 X 1,5 ZFN 744 NBR -70-10	O-RING	O-RING	JOINT TORIQUE			1	1	1	1	1	1			
370	0634 306 170 6 X 1,5 ZFN 744 NBR -70-10	O-RING	O-RING	JOINT TORIQUE			1	1	1	1	1	1			
380	0635 460 027	KUGEL	BALL	BILLE			2	2	2	2	2	2			
390	0732 041 226	DRUCKFEDER	COMPR.SPRING	RESSORT PRESS.			2	2	2	2	2	2			
400	0636 302 014 M 18X1,5 DIN 908 ST	VERSCHL.SCHR.	SCREW PLUG	VIS FERMETURE			3	3	3	3	3	3			
410	0634 306 524 15 X 2 ZFN 744 NBR -70-10	O-RING	O-RING	JOINT TORIQUE			3	3	3	3	3	3			

Gruppe 2094 152 SCHALTUNG
 Group GEARSHIFT SYST.
 Groupe CHANGEMT.VIT.

Stückzahl nach Ausführung / Quantity per model /
 Nombre par modèle

2094 004

11.11.94

Bild Nr. Fig. No. Fig. No.	Teilnummer Partnumber No. de pièce	Benennung	Description	Désignation	Änderung Modification Modification	2094 004							11.11.94		
						alle all tous	002	003	004	005	006	007			
420	0636 302 031 M 10X1 DIN 908 ST	VERSCHL.SCHR.	SCREW PLUG	VIS FERMETURE			12	12	12	12	12	12			
430	0634 303 280 8 X 1,5 ZFN 744 NBR -70-10	O-RING	O-RING	JOINT TORIQUE			12	12	12	12	12	12			
440	4644 306 382	DICHTUNG	GASKET	JOINT			1	1	1	1	1	1			
450	4644 306 511	SCHALTGEHAEUSE	G.SHIFT HOUSING	CART.CDE VIT.			1	1	1	1	1	1			
460	0636 101 011 M 6 X 18 DIN 912 8.8	ZYL.SCHRAUBE	CAP SCREW	VIS TETE CYL.			9	9	9	9	9	9			
470	0630 003 004 6,4 DIN 433 200HV	SCHEIBE	WASHER	RONDELLE			9	9	9	9	9	9			
480	0635 460 005	KUGEL	BALL	BILLE			5	5	5	5	5	5			
490	2093 352 038 2093 352 037 2093 352 040 2093 352 048	KOLBEN WAHLWEISE B=21 B=20,5 B=20,0 B=19,5	PISTON OPTIONAL	PISTON EN OPTION			1 1 1 1	1 1 1 1	1 1 1 1	1 1 1 1	1 1 1 1	1 1 1 1			
500	0635 470 104	WALZE	ROLLER	ROULEAU			1	1	1	1	1	1			
520	4644 306 397	KOLBEN	PISTON	PISTON			1	1	1	1	1	1			
530	0732 042 318	DRUCKFEDER	COMPR.SPRING	RESSORT PRESS.			1	1	1	1	1	1			
540	4644 306 398	KOLBEN	PISTON	PISTON			1	1	1	1	1	1			
550	0732 041 764	DRUCKFEDER	COMPR.SPRING	RESSORT PRESS.			1	1	1	1	1	1			

Gruppe 2094 152 SCHALTUNG
 Group GEARSHIFT SYST.
 Groupe CHANGEMT.VIT.

Stückzahl nach Ausführung / Quantity per model /
 Nombre par modèle

2094 004

11.11.94

Bild Nr. Fig. No. Fig. No.	Teilnummer Partnumber No. de pièce	Benennung	Description	Désignation	Änderung Modification Modification	Stückzahl nach Ausführung / Quantity per model / Nombre par modèle									
						alle all tous	002	003	004	005	006	007			
560	0636 302 001 M 12X1,5 DIN 908 ST	VERSCHL.SCHR.	SCREW PLUG	VIS FERMETURE			1	1	1	1	1	1			
570	0634 303 144 9,5 X 2 ZFN 744 NBR -70-10	O-RING	O-RING	JOINT TORIQUE			1	1	1	1	1	1			
580	0636 302 005 M 20X1,5 DIN 908 ST	VERSCHL.SCHR.	SCREW PLUG	VIS FERMETURE			1	1	1	1	1	1			
590	0634 306 198 17 X 2 ZFN 744 NBR -70-10	O-RING	O-RING	JOINT TORIQUE			1	1	1	1	1	1			
600	2093 352 041	SCHRAUBE	SCREW	VIS			1	1	1	1	1	1			
610	0634 306 524 15 X 2 ZFN 744 NBR -70-10	O-RING	O-RING	JOINT TORIQUE			1	1	1	1	1	1			
620	2094 352 040	DICHTUNG	GASKET	JOINT			1	1	1	1	1	1			
630	2094 352 020	ZWISCHENBLECH	INTERM.SHEET	TOLE INTERM.			1	1	1	1	1	1			
634	2094 352 021	DICHTUNG	GASKET	JOINT			1	1	1	1	1	1			
640	2094 352 019	KANALPLATTE	DUCT PLATE	PLAQUE CANIVEAU			1	1							
	2094 352 044	KANALPLATTE	DUCT PLATE	PLAQUE CANIVEAU					1	1	1	1			
644	4644 306 076	BLENDE	ORIFICE	AJUTAGE			1	1	1	1	1	1			
650	0730 150 663	SCHEIBE	WASHER	RONDELLE			1	1	1	1	1	1			

Gruppe 2094 152 SCHALTUNG
 Group GEARSHIFT SYST.
 Groupe CHANGEMT.VIT.

Stückzahl nach Ausführung / Quantity per model /
 Nombre par modèle

2094 004

11.11.94

Bild Nr. Fig. No. Fig. No.	Teilnummer Partnumber No. de pièce	Benennung	Description	Désignation	Änderung Modification Modification	alle all tous	2094 004								
							002	003	004	005	006	007			
652	0634 313 266 7 X 1,5 ZFN 744 FPM -70-10	O-RING	O-RING	JOINT TORIQUE			1	1	1	1	1	1			
	0634 306 169 7 X 1,5 ZFN 744 NBR -70-10	ANLAUFTEIL O-RING	INTRODUCTION DATE O-RING	MOMENT.D.DEMARRAGE JOINT TORIQUE			1	1							
660	0635 460 302	AUSLAUFTEIL KUGEL	TERMINATING DATE BALL	MOMENT TERMNAISON BILLE			1	1	1	1	1	1			
680	0635 460 027	KUGEL	BALL	BILLE			1	1	1	1	1	1			
690	0732 041 226	DRUCKFEDER	COMPR.SPRING	RESSORT PRESS.			1	1	1	1	1	1			
700	2094 352 022	DICHTUNG	GASKET	JOINT			1	1	1	1	1	1			
740	0736 101 205	ZYL.SCHRAUBE	CAP SCREW	VIS TETE CYL.			16	16	16	16	16	16			
744	0736 101 206	ZYL.SCHRAUBE	CAP SCREW	VIS TETE CYL.			1	1	1	1	1	1			
760	0736 101 202	ZYL.SCHRAUBE	CAP SCREW	VIS TETE CYL.			10	10	10	10	10	10			
770	0630 003 006 8,4 DIN 433 200HV	SCHEIBE	WASHER	RONDELLE			27	27	27	27	27	27			
780	0737 843 077	EINSCHR.STUTZEN	SCREW-IN SLEEVE	RACCORD FILETE			1	1	1	1	1	1			
800	0634 303 283 27 X 2,5 ZFN 744 NBR -70-10	O-RING	O-RING	JOINT TORIQUE			1	1	1	1	1	1			

Gruppe 2094 177 HYDR.SCHALTUNG
Group
Groupe

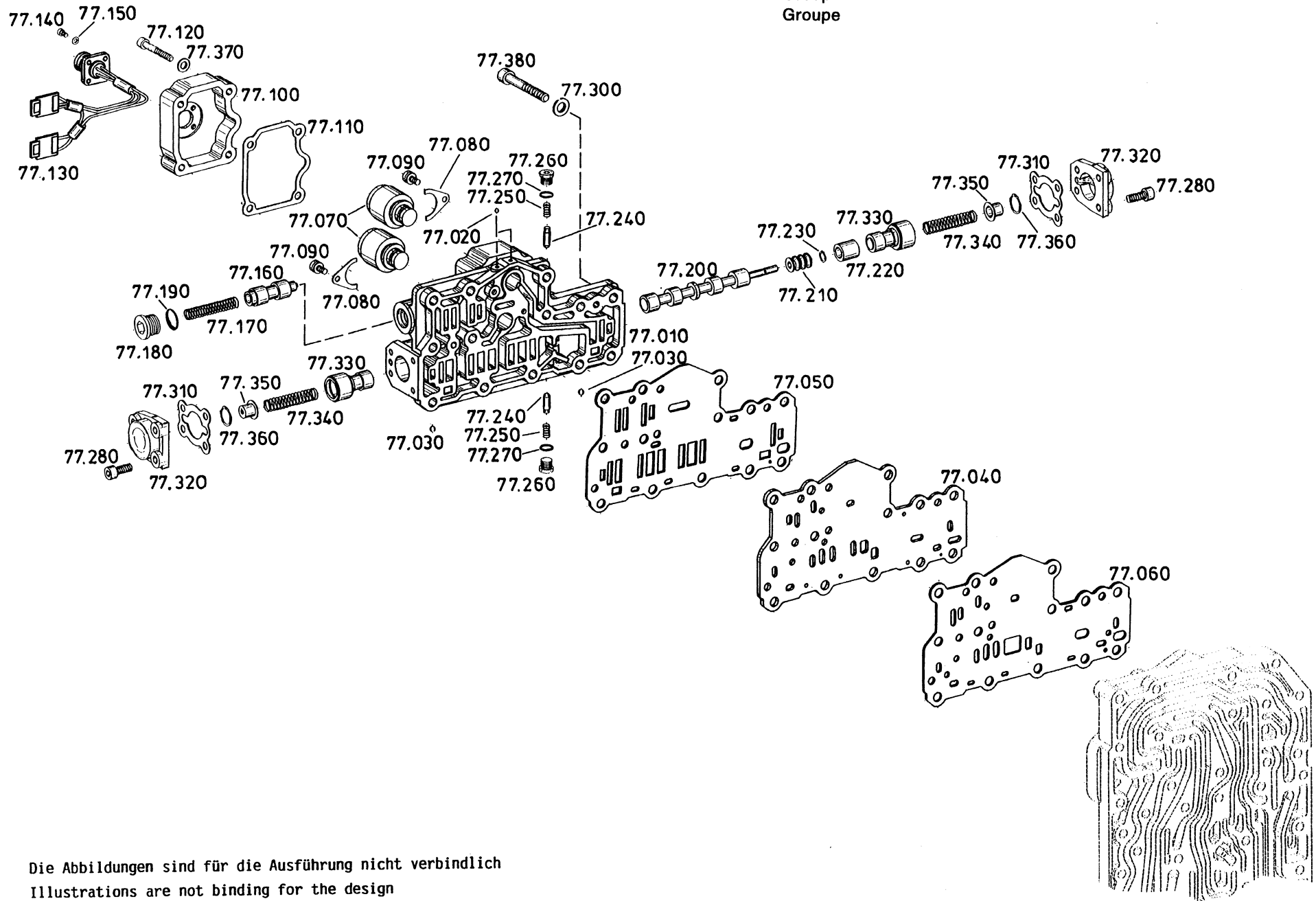

Die Abbildungen sind für die Ausführung nicht verbindlich
Illustrations are not binding for the design
Les illustrations ne sont pas obligatoires pour l'exécution

2094 004

11.11.94

Bild Nr. Fig. No. Fig. No.	Teilnummer Partnumber No. de pièce	Benennung	Description	Désignation	Änderung Modification Modification	2094 004							11.11.94		
						alle all tous	002	003	004	005	006	007			
010	2093 377 026	VENTILBLOCK	VALVE BLOCK	BLOC-VALVES			1	1	1	1	1	1			
020	0635 460 004	KUGEL	BALL	BILLE			2	2	2	2	2	2			
030	0635 460 010	KUGEL	BALL	BILLE			2	2	2	2	2	2			
040	2094 377 049	ZWISCHENPLATTE	INTERM.PLATE	PLAQUE INTERM.			1	1							
	2094 377 054	ZWISCHENPLATTE	INTERM.PLATE	PLAQUE INTERM.					1	1	1	1			
050	2094 377 050	DICHTUNG	GASKET	JOINT			1	1	1	1	1	1			
060	2094 377 051	DICHTUNG	GASKET	JOINT			1	1							
	2094 377 055	DICHTUNG	GASKET	JOINT					1	1	1	1			
070	0501 311 654	MAGNETVENTIL	SOLENOID VALVE	ELECTROVANNE			2	2	2	2	2	2			
080	1043 326 045	HALTEBLECH	FIXING PLATE	TOLE SUPPORT			2	2	2	2	2	2			
090	0636 101 107 M 5 X 10 DIN 912 8.8	ZYL.SCHRAUBE	CAP SCREW	VIS TETE CYL.			2	2	2	2	2	2			
100	2093 377 013	DECKEL	COVER	COUVERCLE			1	1	1	1	1	1			
110	2093 377 016	DICHTUNG	GASKET	JOINT			1	1	1	1	1	1			
120	0636 101 017 M 6 X 35 DIN 912 8.8	ZYL.SCHRAUBE	CAP SCREW	VIS TETE CYL.			4	4	4	4	4	4			
130	2094 277 014	KABELBAUM	WIRING HARNESS	FAISCEAU CABLES			1	1	1	1	1	1			
140	0636 404 298 M 4 X 10 DIN 84 4.8 FE/ZN8C	ZYL.SCHRAUBE	CAP SCREW	VIS TETE CYL.			4	4	4	4	4	4			
150	0630 050 039 U 4,5 X 7	USITRING X1	USIT RING	BAGUE USIT			4	4	4	4	4	4			

Gruppe 2094 177 HYDR. SCHALTUNG
 Group
 Groupe

Stückzahl nach Ausführung / Quantity per model /
 Nombre par modèle

2094 004

11.11.94

Bild Nr. Fig. No. Fig. No.	Teilnummer Partnumber No. de pièce	Benennung	Description	Désignation	Änderung Modification Modification	alle all tous	2094 004								
							002	003	004	005	006	007			
160	2094 377 041	KOLBEN	PISTON	PISTON			1	1	1	1	1	1			
170	0732 042 329	DRUCKFEDER	COMPR.SPRING	RESSORT PRESS.			1	1	1	1	1	1			
180	0636 302 014 M 18X1,5 DIN 908 ST	VERSCHL.SCHR.	SCREW PLUG	VIS FERMETURE			1	1	1	1	1	1			
190	0634 306 524 15 X 2 ZFN 744 NBR -70-10	O-RING	O-RING	JOINT TORIQUE			1	1	1	1	1	1			
200	2093 377 032	KOLBEN	PISTON	PISTON			1	1	1	1	1	1			
210	2093 377 020	RASTE	DETENT	CRAN D'ARRET			1	1	1	1	1	1			
220	2093 377 033	KOLBEN	PISTON	PISTON			1	1	1	1	1	1			
230	0630 501 002 6X0,7 DIN 471	SICHERUNGSRING	RETAINING RING	JONC D'ARRET			1	1	1	1	1	1			
240	2093 377 009	KOLBEN	PISTON	PISTON			2	2	2	2	2	2			
250	0732 041 159	DRUCKFEDER	COMPR.SPRING	RESSORT PRESS.			2	2	2	2	2	2			
260	0636 302 031 M 10X1 DIN 908 ST	VERSCHL.SCHR.	SCREW PLUG	VIS FERMETURE			2	2	2	2	2	2			
270	0634 303 280 8 X 1,5 ZFN 744 NBR -70-10	O-RING	O-RING	JOINT TORIQUE			2	2	2	2	2	2			
280	0636 101 012 M 6 X 20 DIN 912 8.8	ZYL.SCHRAUBE	CAP SCREW	VIS TETE CYL.			8	8	8	8	8	8			

Gruppe 2094 177 HYDR.SCHALTUNG
 Group
 Groupe

Stückzahl nach Ausführung / Quantity per model /
 Nombre par modèle

2094 004

11.11.94

Bild Nr. Fig. No. Fig. No.	Teilnummer Partnumber No. de pièce	Benennung	Description	Désignation	Änderung Modification Modification	alle all tous								
						002	003	004	005	006	007			
300	0630 003 006 8,4 DIN 433 200HV	SCHEIBE	WASHER	RONDELLE		13	13	13	13	13	13			
310	2093 377 014	DICHTUNG	GASKET	JOINT		2	2	2	2	2	2			
320	2093 377 012	DECKEL	COVER	COUVERCLE		2	2	2	2	2	2			
330	2093 377 023	KOLBEN	PISTON	PISTON		2	2	2	2	2	2			
340	0732 040 722	DRUCKFEDER	COMPR.SPRING	RESSORT PRESS.		2	2	2	2	2	2			
350	2093 377 024	KAPPE	CAP	CAPUCHON		2	2	2	2	2	2			
360	0630 532 140 JV 18	V-RING	V-RING	BAGUE-V		2	2	2	2	2	2			
370	0630 003 004 6,4 DIN 433 200HV	SCHEIBE	WASHER	RONDELLE		4	4	4	4	4	4			
380	0736 101 204	ZYL.SCHRAUBE	CAP SCREW	VIS TETE CYL.		13	13	13	13	13	13			

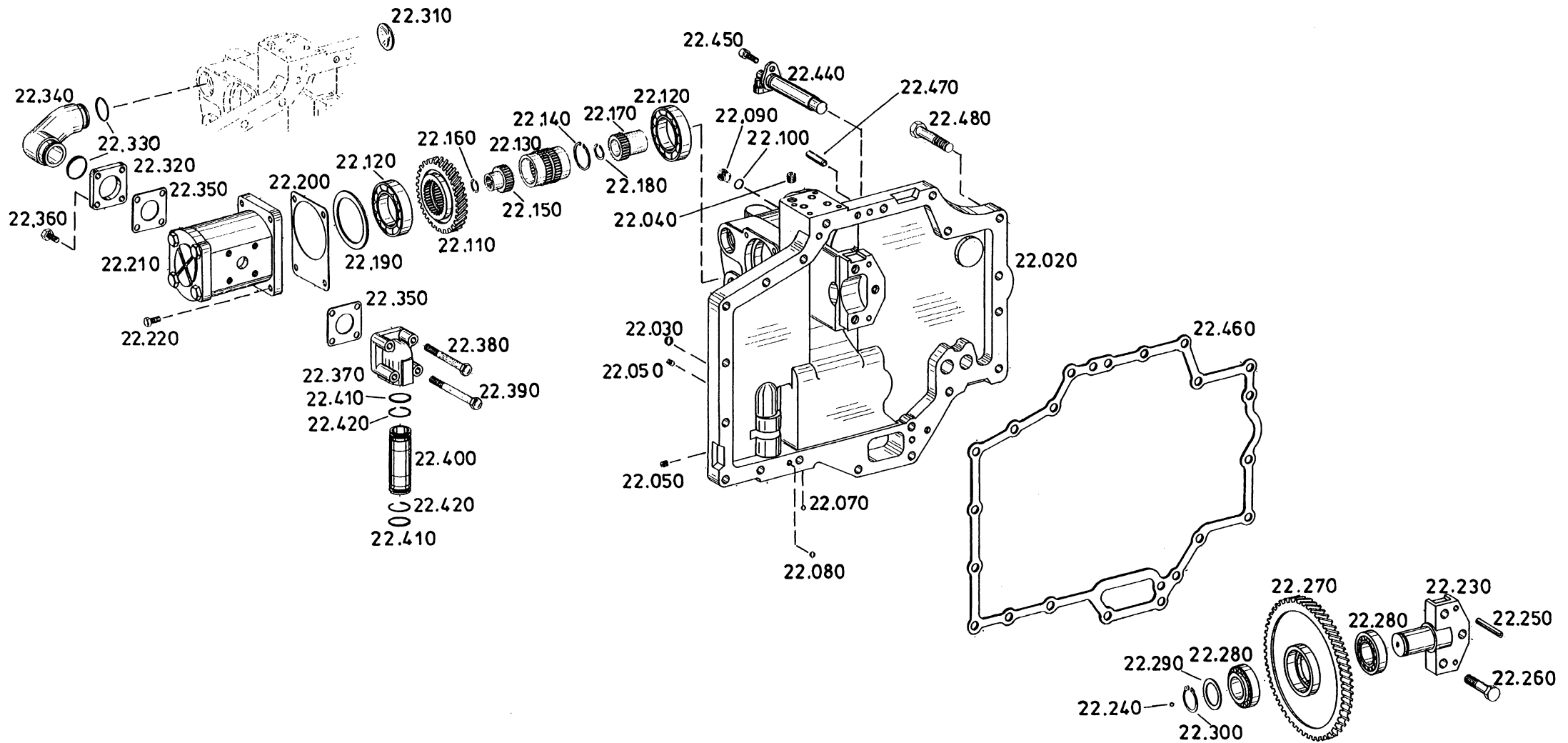

Die Abbildungen sind für die Ausführung nicht verbindlich
 Illustrations are not binding for the design
 Les illustrations ne sont pas obligatoires pour l'exécution

Gruppe 2094 122 PUMPENANTRIEB
 Group PUMP DRIVE
 Groupe ENTRAIN.POMPE

Stückzahl nach Ausführung / Quantity per model /
 Nombre par modèle

2094 004

11.11.94

Bild Nr. Fig. No. Fig. No.	Teilnummer Partnumber No. de pièce	Benennung	Description	Désignation	Änderung Modification Modification	alle all tous								
						002	003	004	005	006	007			
020	2094 322 040 2094 322 042	GEHAEUSE AUSLAUFTEIL GEHAEUSE	HOUSING TERMINATING DATE HOUSING	CARTER MOMENT TERMNAISON CARTER	KO1133/941 KO1133/941	1	1	1	1	1	1			
		ANLAUFTEIL	INTRODUCTION DATE	MOMENT.D.DEMARRAGE										
030	0635 460 023	KUGEL	BALL	BILLE		1	1	1	1	1	1			
040	0631 610 128 M 14 X12 DIN 913 45H	GEWINDESTIFT	SET SCREW	GOUJON FILETE		1	1	1	1	1	1			
050	0631 610 107 M 8 X 6 DIN 913 45H	GEWINDESTIFT	SET SCREW	GOUJON FILETE		2	2	2	2	2	2			
070	0635 460 012	KUGEL	BALL	BILLE		1	1	1	1	1	1			
080	0635 460 017	KUGEL	BALL	BILLE		1	1	1	1	1	1			
090	0636 302 031 M 10X1 DIN 908 ST	VERSCHL.SCHR.	SCREW PLUG	VIS FERMETURE		2	2	2	2	2	2			
100	0634 303 280 8 X 1,5 ZFN 744 NBR -70-10	O-RING	O-RING	JOINT TORIQUE		2	2	2	2	2	2			
110	2094 322 035 Z=41	STIRNRAD	SPUR GEAR	PIGNON CYLINDR.		1	1	1	1	1	1			
120	0750 116 176	KUGELLAGER	BALL BEARING	ROULEM.A BILLES		2	2	2	2	2	2			
130	2094 322 027	BUCHSE	BUSH	DOUILLE		1	1	1	1	1	1			
140	0630 502 018 35X1,5 DIN 472	SICHERUNGSRING	RETAINING RING	JONC D'ARRET		1	1	1	1	1	1			
150	2094 322 028	BUCHSE	BUSH	DOUILLE		1	1	1	1	1	1			

Gruppe 2094 122 PUMPENANTRIEB
 Group PUMP DRIVE
 Groupe ENTRAIN.POMPE

Stückzahl nach Ausführung / Quantity per model /
 Nombre par modèle

2094 004

11.11.94

Bild Nr. Fig. No. Fig. No.	Teilnummer Partnumber No. de pièce	Benennung	Description	Désignation	Änderung Modification Modification	2094 004							11.11.94		
						alle all tous	002	003	004	005	006	007			
160	0630 502 002 14X1 DIN 472	SICHERUNGSRING	RETAINING RING	JONC D'ARRET			1	1	1	1	1	1			
170	2094 322 029	BUCHSE	BUSH	DOUILLE			1	1	1	1	1	1			
180	0630 502 007 20X1 DIN 472	SICHERUNGSRING	RETAINING RING	JONC D'ARRET			1	1	1	1	1	1			
190		SCHEIBE WAHLWEISE	WASHER OPTIONAL	RONDELLE EN OPTION											
	0730 109 589	S=2,8					1	1	1	1	1	1			
	1232 304 085	S=2,6					1	1	1	1	1	1			
	0730 109 590	S=3,0					1	1	1	1	1	1			
	0730 109 591	S=3,1					1	1	1	1	1	1			
	1232 304 061	S=2,4					1	1	1	1	1	1			
	0730 109 066	S=2,9					1	1	1	1	1	1			
	0730 109 067	S=3,2					1	1	1	1	1	1			
200	2052 322 097	DICHTUNG	GASKET	JOINT			1	1	1	1	1	1			
210	0501 004 870	PUMPE	PUMP	POMPE			1	1	1	1	1	1			
220	0636 015 089 M 8 X 25 DIN 933 8.8	6KT.SCHRAUBE	HEXAGON SCREW	VIS HEXAGONALE			4	4	4	4	4	4			
230	2094 322 032	LAGERBOCK	BRACKET	SUPPORT			1	1	1	1	1	1			
240	0635 460 010	KUGEL	BALL	BILLE			1	1	1	1	1	1			
250	0631 306 754 8 M 6X 36 ZFN 6 16MNCR5 E	ZYLINDERSTIFT	CYLINDRICAL PIN	GOUPILLE CYL.			2	2	2	2	2	2			
260	0636 011 356 M 12 X 45 DIN 931 10.9	6KT.SCHRAUBE	HEXAGON SCREW	VIS HEXAGONALE			3	3	3	3	3	3			

Gruppe 2094 122 PUMPENANTRIEB
 Group PUMP DRIVE
 Groupe ENTRAIN. POMPE

Stückzahl nach Ausführung / Quantity per model /
 Nombre par modèle

2094 004

11.11.94

Bild Nr. Fig. No. Fig. No.	Teilnummer Partnumber No. de pièce	Benennung	Description	Désignation	Änderung Modification Modification	alle all tous	2094 004								
							002	003	004	005	006	007			
270	2094 322 036 Z=75	STIRNRAD	SPUR GEAR	PIGNON CYLINDR.			1	1	1	1	1	1			
280	0635 370 039	ROLLENLAGER	ROLLER BEARING	ROULEM.A ROUL.			2	2	2	2	2	2			
290		AUSGL. SCHEIBE WAHLWEISE	SHIM OPTIONAL	RONDELLE EN OPTION											
	0730 006 994	A=2,00					1	1	1	1	1	1			
	0730 006 995	A=2,05					1	1	1	1	1	1			
	0730 006 996	A=2,10					1	1	1	1	1	1			
	0730 006 997	A=2,15					1	1	1	1	1	1			
	0730 006 998	A=2,20					1	1	1	1	1	1			
	0730 006 999	A=2,25					1	1	1	1	1	1			
	0730 007 001	A=2,30					1	1	1	1	1	1			
	0730 007 002	A=2,35					1	1	1	1	1	1			
	0730 007 003	A=2,40					1	1	1	1	1	1			
	0730 007 004	A=2,45					1	1	1	1	1	1			
	0730 007 005	A=2,50					1	1	1	1	1	1			
	0730 007 232	A=1,80					1	1	1	1	1	1			
	0730 007 600	A=1,85					1	1	1	1	1	1			
	0730 007 569	A=1,9					1	1	1	1	1	1			
	0730 007 570	A=1,95					1	1	1	1	1	1			
300	0630 531 036 30X2 DIN 471	SICHERUNGSRING	RETAINING RING	JONC D'ARRET			1	1	1	1	1	1			
310	0630 362 040 34 DIN 470	VERSCHL. SCHEIBE	SEALING DISC	RONDELLE FERMET			1	1	1	1	1	1			
320	2094 336 015	FLANSCH	FLANGE	BRIDE			1	1	1	1	1	1			
330	0634 303 312 30 X 2,5 ZFN 744 NBR -70-10	O-RING	O-RING	JOINT TORIQUE			2	2	2	2	2	2			
340	2094 347 011	KRUEMMER	MANIFOLD	COUDE			1	1	1	1	1	1			
350	2094 322 018	DICHTUNG	GASKET	JOINT			2	2	2	2	2	2			

Gruppe 2094 122 PUMPENANTRIEB
 Group PUMP DRIVE
 Groupe ENTRAIN. POMPE

Stückzahl nach Ausführung / Quantity per model /
 Nombre par modèle

2094 004

11.11.94

Bild Nr. Fig. No. Fig. No.	Teilnummer Partnumber No. de pièce	Benennung	Description	Désignation	Änderung Modification Modification	alle all tous	2094 004								
							002	003	004	005	006	007			
360	0636 015 084 M 8 X 22 DIN 933 8.8	6KT.SCHRAUBE	HEXAGON SCREW	VIS HEXAGONALE			4	4	4	4	4	4			
370	2094 347 012	KRUEMMER	MANIFOLD	COUDE			1	1	1	1	1	1			
380	0636 010 084 M 8 X 45 DIN 931 8.8	6KT.SCHRAUBE	HEXAGON SCREW	VIS HEXAGONALE			2	2	2	2	2	2			
390	0636 010 092 M 8 X 55 DIN 931 8.8	6KT.SCHRAUBE	HEXAGON SCREW	VIS HEXAGONALE			2	2	2	2	2	2			
400	2094 347 037	ROHR	PIPE	TUBE			1	1	1	1	1	1			
410	0634 306 214 23 X 2,5 ZFN 744 NBR -70-10	O-RING	O-RING	JOINT TORIQUE			2	2	2	2	2	2			
420	0630 505 521 A 28 DIN 7993	SPRENGRING	SNAP RING	CIRCLIP			2	2	2	2	2	2			
440	0501 209 645	DREHZAHLGEBER	SPEED TRANSMITT	CAPTEUR TACHYM.			1	1	1	1	1	1			
450	0636 101 027 M 8 X 20 DIN 912 8.8	ZYL.SCHRAUBE	CAP SCREW	VIS TETE CYL.			1	1	1	1	1	1			
460	2094 322 041	DICHTUNG	GASKET	JOINT			1	1	1	1	1	1			
470	0631 306 076 10 M 6X 35 ZFN 6 ST50K * 9S20K	ZYLINDERSTIFT	CYLINDRICAL PIN	GOUPILLE CYL.			2	2	2	2	2	2			

Gruppe 2094 122 PUMPENANTRIEB
 Group PUMP DRIVE
 Groupe ENTRAIN. POMPE

Stückzahl nach Ausführung / Quantity per model /
 Nombre par modèle

2094 004

11.11.94

Bild Nr. Fig. No. Fig. No.	Teilnummer Partnumber No. de pièce	Benennung	Description	Désignation	Änderung Modification Modification	Stückzahl nach Ausführung / Quantity per model / Nombre par modèle									
						alle all tous	002	003	004	005	006	007			
480	0636 010 156 M 10 X 40 DIN 931 8.8	6KT.SCHRAUBE	HEXAGON SCREW	VIS HEXAGONALE			13	13	13	13	13	13			
	0636 010 174 M 10 X 60 DIN 931 8.8	6KT.SCHRAUBE	HEXAGON SCREW	VIS HEXAGONALE			3	3	3	3	3	3			
	0636 010 192 M 10 X 95 DIN 931 8.8	6KT.SCHRAUBE	HEXAGON SCREW	VIS HEXAGONALE			2	2	2	2	2	2			
	0636 010 200 M 10 X110 DIN 931 8.8	6KT.SCHRAUBE	HEXAGON SCREW	VIS HEXAGONALE			2	2	2	2	2	2			

Gruppe 2094 136 OELVERSORGUNG
Group OIL SUPPLY
Groupe ALIMENT•HUILE

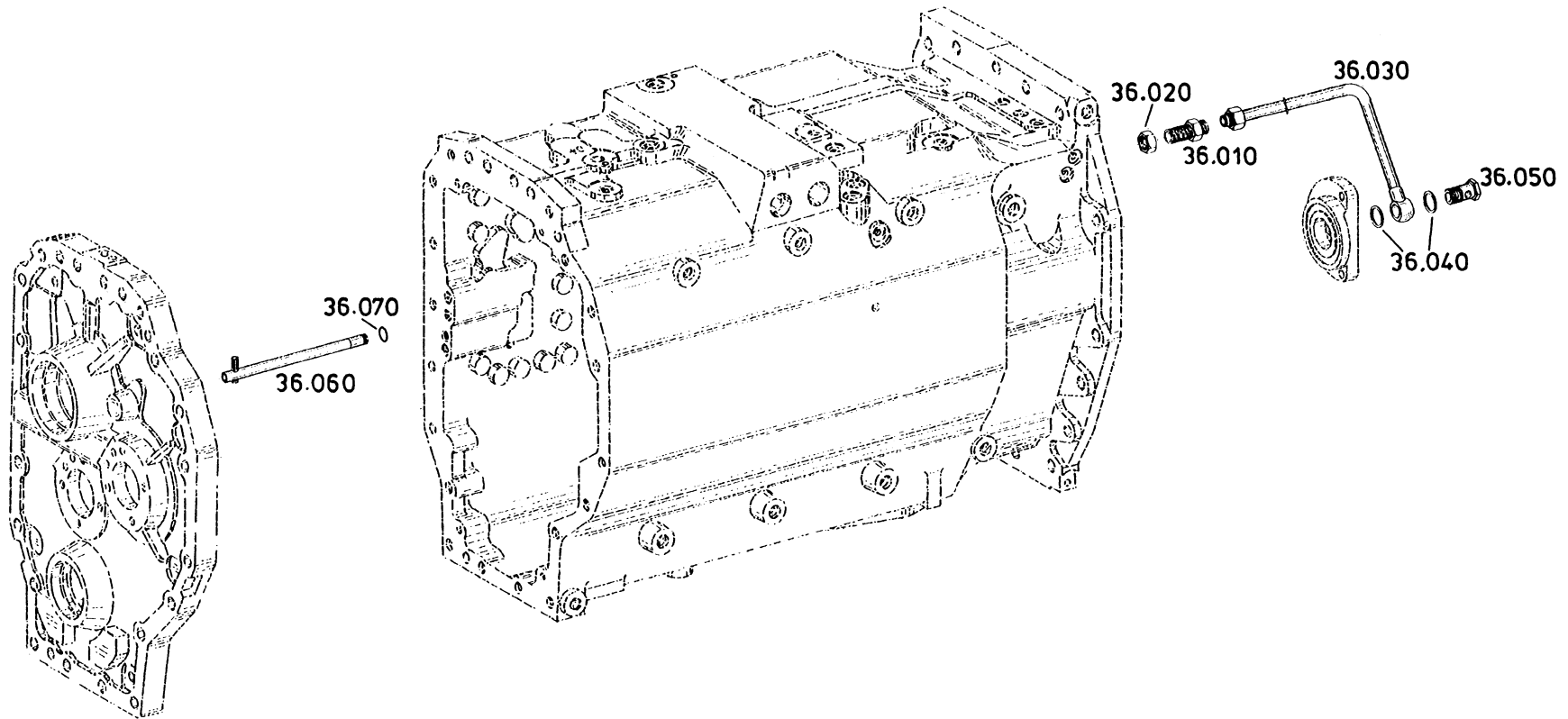

Die Abbildungen sind für die Ausführung nicht verbindlich
Illustrations are not binding for the design
Les illustrations ne sont pas obligatoires pour l'exécution

Gruppe 2094 136 OELVERSORGUNG
 Group OIL SUPPLY
 Groupe ALIMENT. HUILE

Stückzahl nach Ausführung / Quantity per model /
 Nombre par modèle

2094 004

11.11.94

Bild Nr. Fig. No. Fig. No.	Teilnummer Partnumber No. de pièce	Benennung	Description	Désignation	Änderung Modification Modification	alle all tous									
							002	003	004	005	006	007			
010	0637 846 604 L 18 DIN 3910 ST	SCHOTTSTUTZEN	NIPPLE	MANCHON			1	1	1	1	1	1			
020	0637 019 004 M 26X1,5 DIN 80705 ALT 5S FE/ZNPHR8F	MUTTER AUSG.6.69	NUT	ECROU			1	1	1	1	1	1			
030	2094 236 001	ROHR	PIPE	TUBE			1	1	1	1	1	1			
040	0634 801 073 A 22 X 27 DIN 7603 ST	DICHTRING	SEALING RING	BAGUE ETANCH.			2	2	2	2	2	2			
050	0637 835 006 18 DIN 7643	HOHLSCHRAUBE	UNION SCREW	VIS CREUSE			1	1	1	1	1	1			
060	2094 236 002	ROHR	PIPE	TUBE			1	1	1	1	1	1			
070	0634 306 186 12 X 1,5 ZFN 744 NBR -70-10	O-RING	O-RING	JOINT TORIQUE			1	1	1	1	1	1			

Gruppe 2094 147 OELVERSORGUNG
 Group OIL SUPPLY
 Groupe ALIMENTATION HUILE

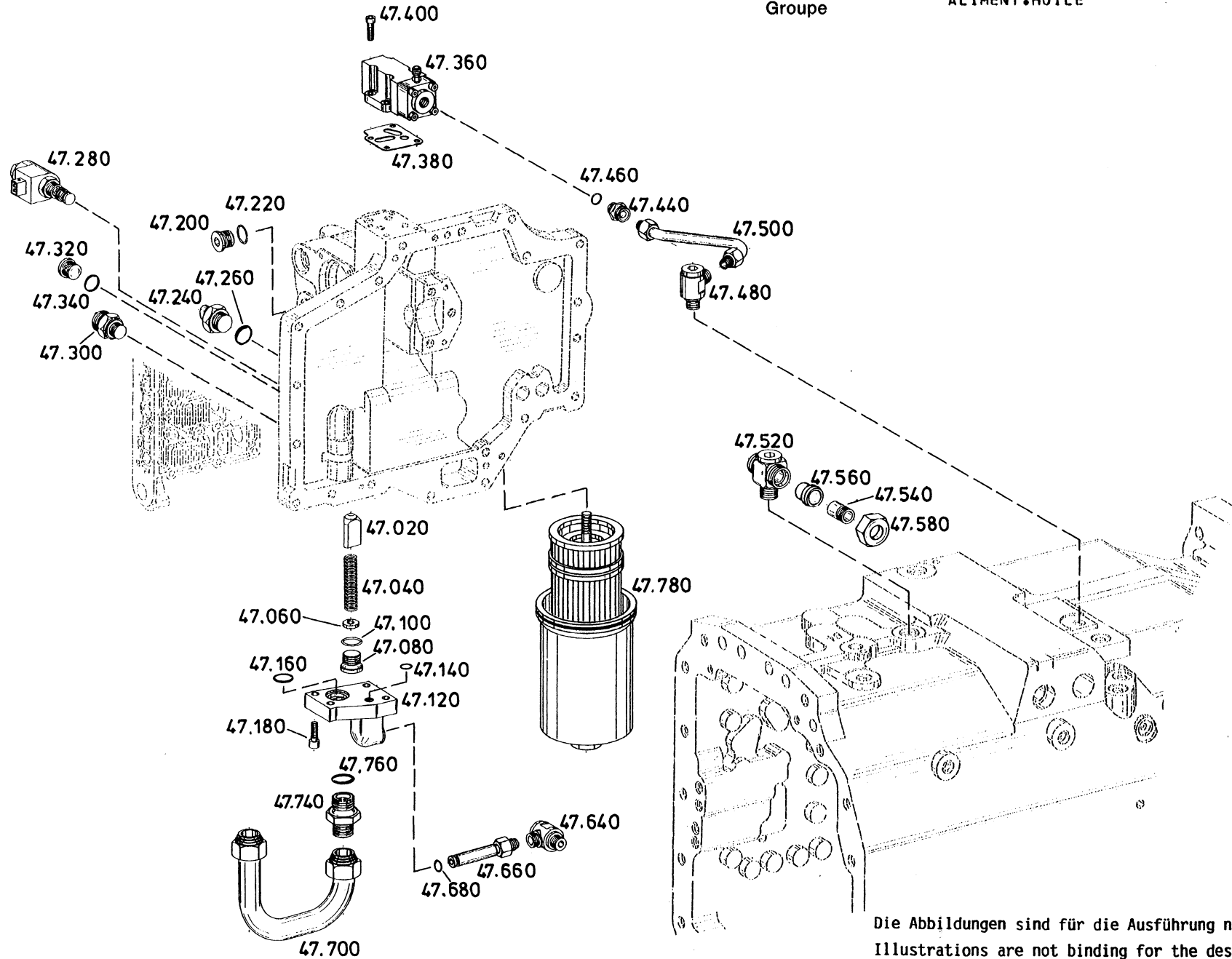

Die Abbildungen sind für die Ausführung nicht verbindlich
 Illustrations are not binding for the design
 Les illustrations ne sont pas obligatoires pour l'exécution

Gruppe 2094 147 OELVERSORGUNG
 Group OIL SUPPLY
 Groupe ALIMENT.HUILE

Stückzahl nach Ausführung / Quantity per model /
 Nombre par modèle

2094 004

11.11.94

Bild Nr. Fig. No. Fig. No.	Teilnummer Partnumber No. de pièce	Benennung	Description	Désignation	Änderung Modification Modification	2094 004							11.11.94		
						alle all tous	002	003	004	005	006	007			
020	2094 336 030	VENTILKEGEL	VALVE CONE	CONE DE VALVE			1	1	1	1	1	1			
040	1405 301 021	DRUCKFEDER	COMPR.SPRING	RESSORT PRESS.			1	1	1	1	1	1			
060		ANLAUFSCHEIBE WAHLWEISE	THRUST WASHER OPTIONAL	RONDELLE BUTEE EN OPTION											
	0770 032 658						1								
	0770 032 662							1	1	1	1	1			
	0770 032 659							1	1	1	1	1			
	0770 032 663							1	1	1	1	1			
	0770 032 964							1	1	1	1	1			
	0770 032 965							1	1	1	1	1			
	0770 032 966							1	1	1	1	1			
	0770 032 967							1	1	1	1	1			
	0770 032 657							1	1	1	1	1			
	0770 032 661							1	1	1	1	1			
	0770 032 658							1	1	1	1	1			
080	0636 302 008 M 26X1,5 DIN 908 ST	VERSCHL.SCHR.	SCREW PLUG	VIS FERMETURE			1	1	1	1	1	1			
100	0634 303 233 23 X 2 ZFN 744 NBR -70-10	O-RING	O-RING	JOINT TORIQUE			1	1	1	1	1	1			
120	2094 347 031	FLANSCH	FLANGE	BRIDE			1	1	1	1	1	1			

Gruppe 2094 147 OELVERSORGUNG
 Group OIL SUPPLY
 Groupe ALIMENT.HUILE

Stückzahl nach Ausführung / Quantity per model /
 Nombre par modèle

2094 004

11.11.94

Bild Nr. Fig. No. Fig. No.	Teilnummer Partnumber No. de pièce	Benennung	Description	Désignation	Änderung Modification Modification	alle all tous									
						002	003	004	005	006	007				
140	O634 313 035 8 X 2,5 ZFN 744 FPM -70-10	O-RING	O-RING	JOINT TORIQUE		1	1	1	1	1	1				
160	O634 303 293 28 X 3 ZFN 744 NBR -70-10	O-RING	O-RING	JOINT TORIQUE		1	1	1	1	1	1				
180	O636 101 031 M 8 X 30 DIN 912 8.8	ZYL.SCHRAUBE	CAP SCREW	VIS TETE CYL.		4	4	4	4	4	4				
200	O636 302 015 M 22X1,5 DIN 908 ST	VERSCHL.SCHR.	SCREW PLUG	VIS FERMETURE		1	1	1	1	1	1				
220	O634 304 287 19 X 2 ZFN 744 NBR -70-10	O-RING	O-RING	JOINT TORIQUE		1	1	1	1	1	1				
240	O501 313 601	SCHALTER	SWITCH	INTERRUPTEUR		1	1	1	1	1	1				
260	O634 304 287 19 X 2 ZFN 744 NBR -70-10	O-RING	O-RING	JOINT TORIQUE		1	1	1	1	1	1				
280	O501 314 603	MAGNETVENTIL	SOLENOID VALVE	ELECTROVANNE		1	1	1	1	1	1				
300	O501 310 043	KONTR.SCHALTER	CONTROL SWITCH	CONTACTEUR TEM.		1	1	1	1	1	1				
320	O636 302 014 M 18X1,5 DIN 908 ST	VERSCHL.SCHR.	SCREW PLUG	VIS FERMETURE		1	1	1	1	1	1				

Gruppe 2094 147 OELVERSORGUNG
 Group OIL SUPPLY
 Groupe ALIMENT.HUILE

Stückzahl nach Ausführung / Quantity per model /
 Nombre par modèle

2094 004

11.11.94

Bild Nr. Fig. No. Fig. No.	Teilnummer Partnumber No. de pièce	Benennung	Description	Désignation	Änderung Modification Modification	Stückzahl nach Ausführung / Quantity per model / Nombre par modèle								
						alle all tous	002	003	004	005	006	007		
340	0634 306 524 15 X 2 ZFN 744 NBR -70-10	O-RING	O-RING	JOINT TORIQUE			1	1	1	1	1	1		
360	0501 209 244	VENTIL	VALVE	VALVE			1	1	1	1	1	1		
380	2094 347 038	DICHTUNG	GASKET	JOINT			1	1	1	1	1	1		
400	0636 101 029 M 8 X 25 DIN 912 8.8	ZYL.SCHRAUBE	CAP SCREW	VIS TETE CYL.			4	4	4	4	4	4		
440	0637 842 510 L 12 BM DIN 3901 ST	EINSCHR.STUTZEN	SCREW-IN SLEEVE	RACCORD FILETE			1	1	1	1	1	1		
460	0634 306 012 13,3 X 2,4 ZFN 744 NBR -70-10	O-RING	O-RING	JOINT TORIQUE			1	1	1	1	1	1		
480	0501 309 404	VERSCHRAUBUNG	PIPE UNION	RACCORD A VIS			1	1	1	1	1	1		
500	2094 247 016	ROHR	PIPE	TUBE			1	1	1	1	1	1		
520	0637 885 214 DSVT 22-LM OMD	VERSCHRAUBUNG	PIPE UNION	RACCORD A VIS			1	1	1	1	1	1		
540	0637 885 213 XKOR 22/15-PL	REDUZIERUNG	REDUCER	REDUCTION			1	1	1	1	1	1		
560	0637 880 035 L 22 DIN 3861 ST	SCHNEIDRING	CUTTING RING	BAGUE DE COUPE			1	1	1	1	1	1		

Gruppe 2094 147 OELVERSORGUNG
 Group OIL SUPPLY
 Groupe ALIMENT.HUILE

Stückzahl nach Ausführung / Quantity per model /
 Nombre par modèle

2094 004

11.11.94

Bild Nr. Fig. No. Fig. No.	Teilnummer Partnumber No. de pièce	Benennung	Description	Désignation	Änderung Modification Modification	2094 004									
						alle all tous	002	003	004	005	006	007			
580	0637 880 047 AL 22 DIN 3870	UEBERWURFMUTTER	UNION NUT	ECROU - CHAPEAU			1	1	1	1	1	1			
640	0501 309 404	VERSCHRAUBUNG	PIPE UNION	RACCORD A VIS			1	1	1	1	1	1			
660	2094 247 015	ROHR	PIPE	TUBE			1	1	1	1	1	1			
680	0634 313 593 10 X 2,5 ZFN 744 FPM -80-10	O-RING	O-RING	JOINT TORIQUE			1	1	1	1	1	1			
700	2094 247 017	ROHR	PIPE	TUBE			1	1	1	1	1	1			
740	0637 885 316 GE 28-LM-OMD	VERSCHRAUBUNG	PIPE UNION	RACCORD A VIS			1	1	1	1	1	1			
760	0634 306 047 30 X 3 ZFN 744 NBR -70-10	O-RING	O-RING	JOINT TORIQUE			1	1	1	1	1	1			
780	---	SAUGFILTER**	SUCTION FILTER*	FILTRE D'ASPIR.*			1	1	1	1	1	1			
		* SIEHE SEITE 79	* SEE PAGE 79	* VOYEZ PAGE 79											

Gruppe 2094 199 LOSTEILE
Group LOOSE PARTS
Groupe PCES.DETACHEES

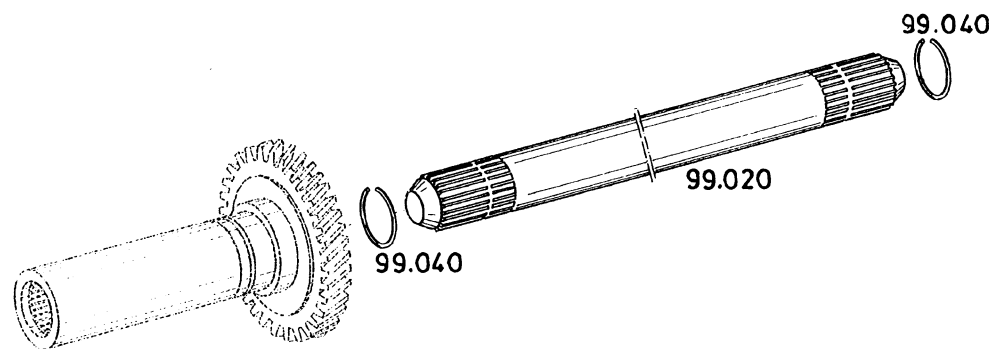

Die Abbildungen sind für die Ausführung nicht verbindlich
Illustrations are not binding for the design
Les illustrations ne sont pas obligatoires pour l'exécution

Gruppe 2094 199 LOSTEILE
Group LOOSE PARTS
Groupe PCES .DETACHEES

Stückzahl nach Ausführung / Quantity per model /
Nombre par modèle

2094 004

11.11.94

Bild Nr. Fig. No. Fig. No.	Teilnummer Partnumber No. de pièce	Benennung	Description	Désignation	Änderung Modification Modification	alle all tous								
						002	003	004	005	006	007			
020	2094 310 005	WELLE	SHAFT	ARBRE		1	1	1	1	1	1			
040	0630 505 535 A 35 DIN 7993	SPRENGRING	SNAP RING	CIRCLIP		2	2	2	2	2	2			

Gruppe 0501 209 FILTER
Group FILTER
Groupe FILTRE

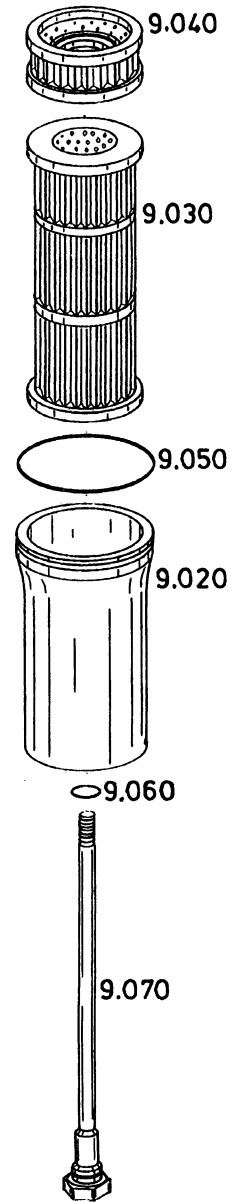

Die Abbildungen sind für die Ausführung nicht verbindlich
Illustrations are not binding for the design
Les illustrations ne sont pas obligatoires pour l'exécution

Gruppe 0501 209 FILTER
 Group FILTER
 Groupe FILTRE

Stückzahl nach Ausführung / Quantity per model /
 Nombre par modèle

2094 004

11.11.94

Bild Nr. Fig. No. Fig. No.	Teilnummer Partnumber No. de pièce	Benennung	Description	Désignation	Änderung Modification Modification	alle all tous									
						002	003	004	005	006	007				
---	0501 209 080	FILTER KPL. BESTEHEND AUS BILD NR. 020-070	FILTER CPL. CONSISTING OF FIG NO. 020-070	FILTRE CPL. COMPOSE DE FIG NO. 020-070			1	1	1	1	1	1			
020	0501 314 632	GEHAEUSE	HOUSING	CARTER			1	1	1	1	1	1			
030	0501 314 626	PAPIERFILTER	PAPERFILTER	FILTRE EN PAPIER			1	1	1	1	1	1			
040	0501 314 634	VENTILSCHUTZSIEB	SCREEN FILTER	FILTRE MICROMETRIQUE			1	1	1	1	1	1			
050	0634 313 487 112x3 ZFN 744 FPM -70-10	O-RING	O-RING	JOINT TORIQUE			1	1	1	1	1	1			
060	0634 313 198 20x3 ZFN 744 FPM -70-10	O-RING	O-RING	JOINT TORIQUE			1	1	1	1	1	1			
070	0501 209 279	STAB KPL. MIT BILD NR. 060	BAR CPL. WITH FIG NO. 060	BARRE CPL. AVEC FIG NO. 060			1	1	1	1	1	1			

